

FSMD

Last updated 1/28/21

FSMD

- Overview

- FSM with Data Path

- FSM

- Control the Data Path

- Data Path

- Sequential circuitry to accomplish a task
 - Typically register transfer operations

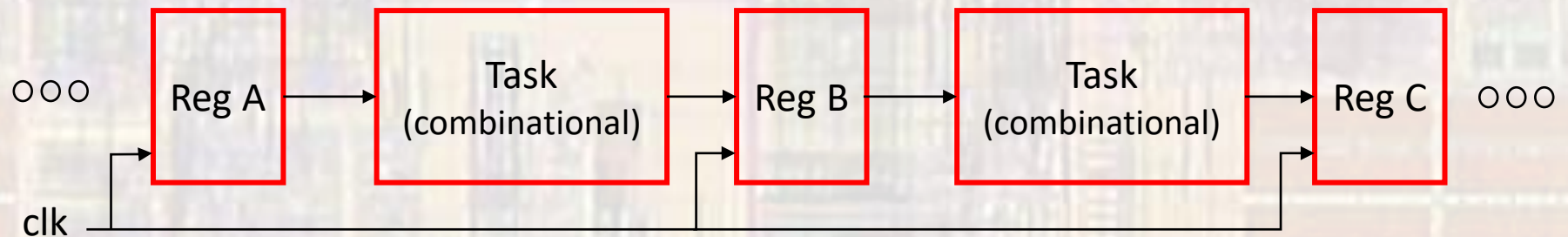

FSMD

- Overview
 - FSM with Data Path
 - Data Path
 - Simplifies if Task is repeated

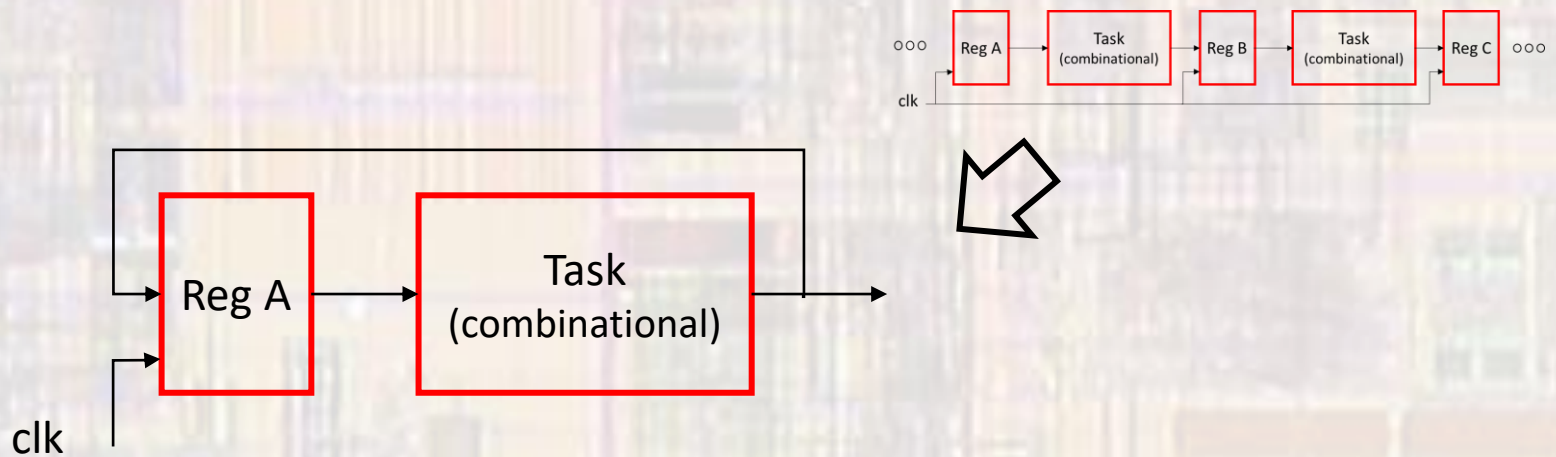

FSMD

- Block Diagram

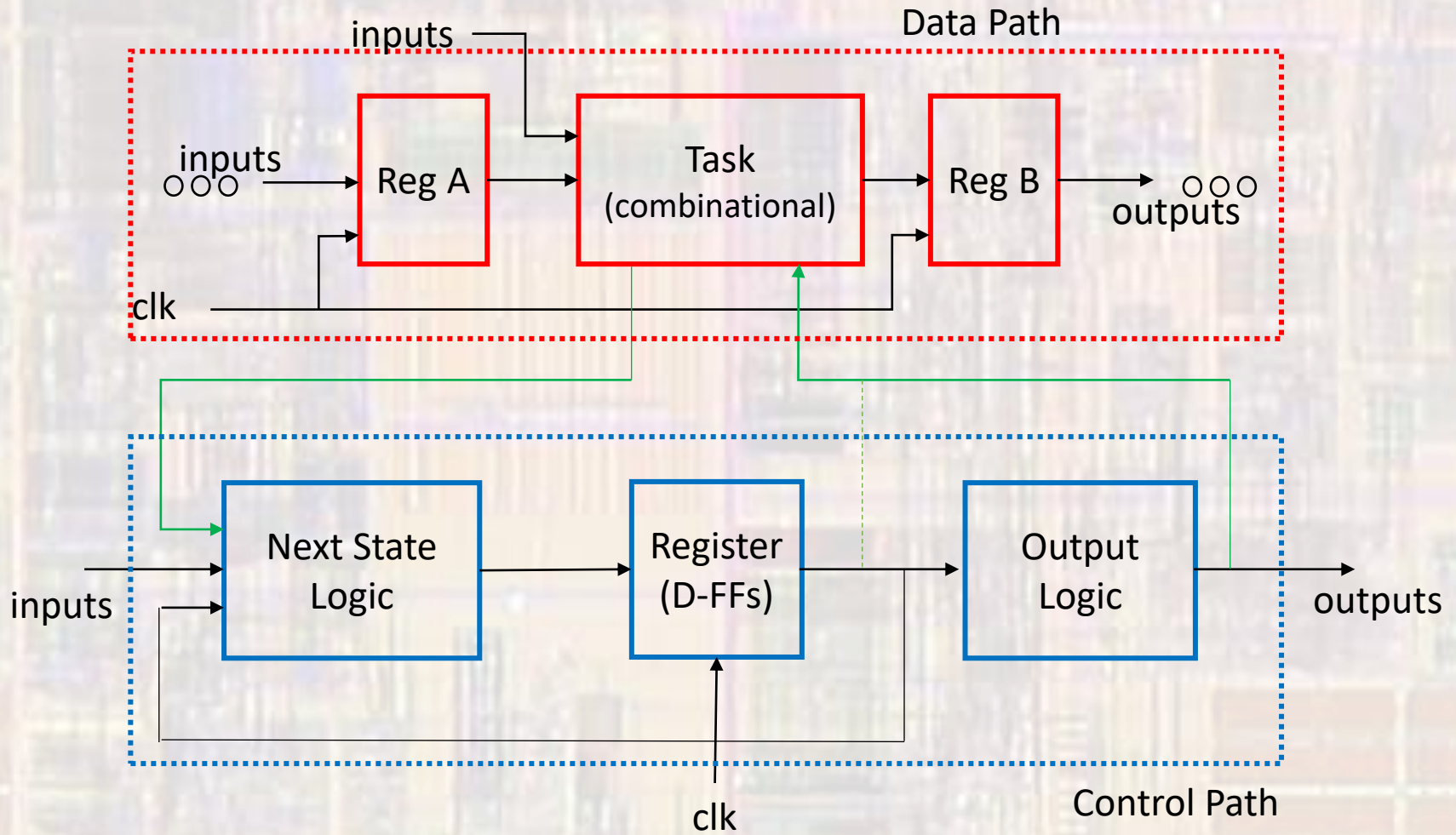

FSMD

- Block Diagram

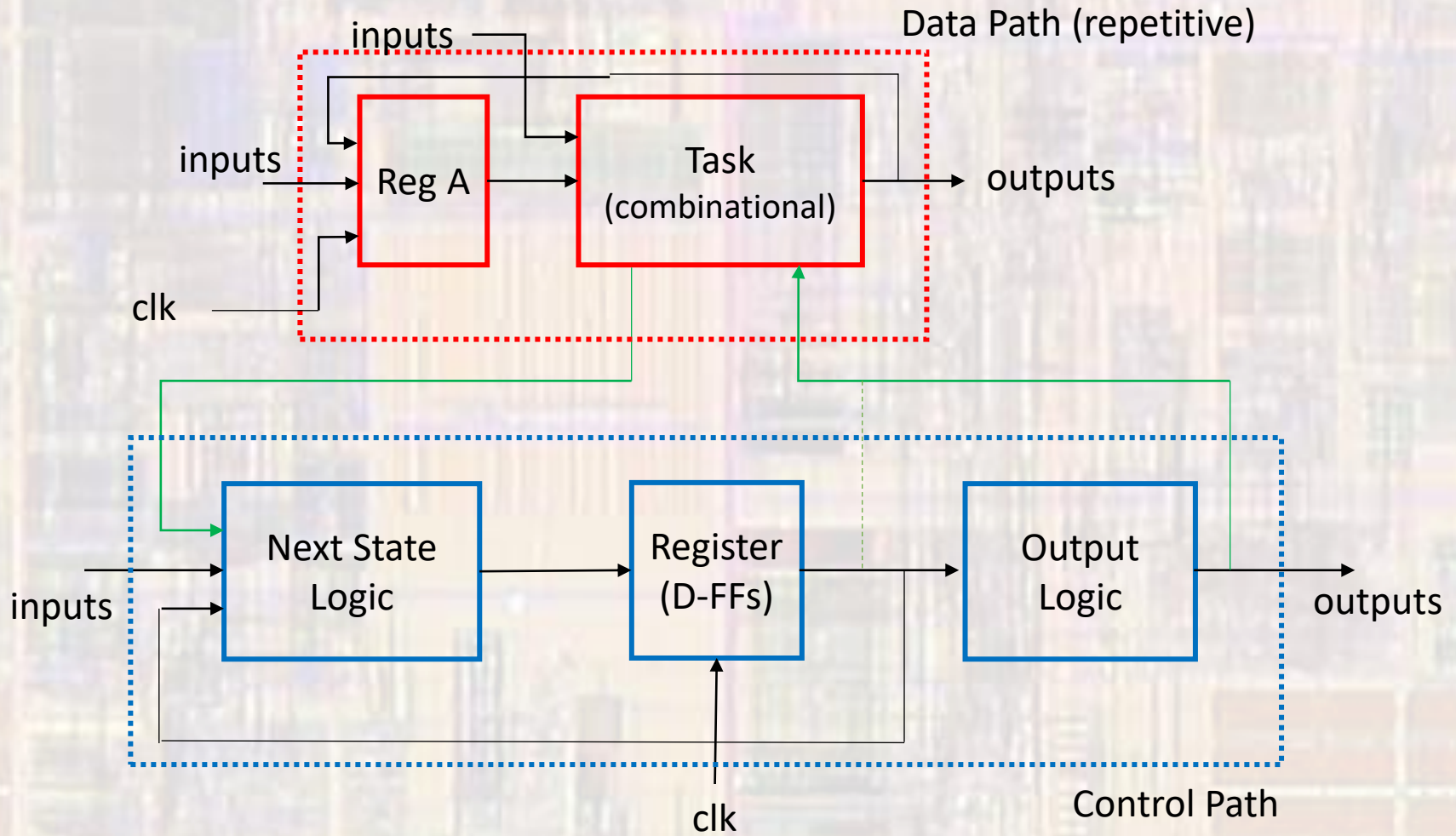

FSMD

- Data Path
 - Real Polynomial generator
 - A-H fixed

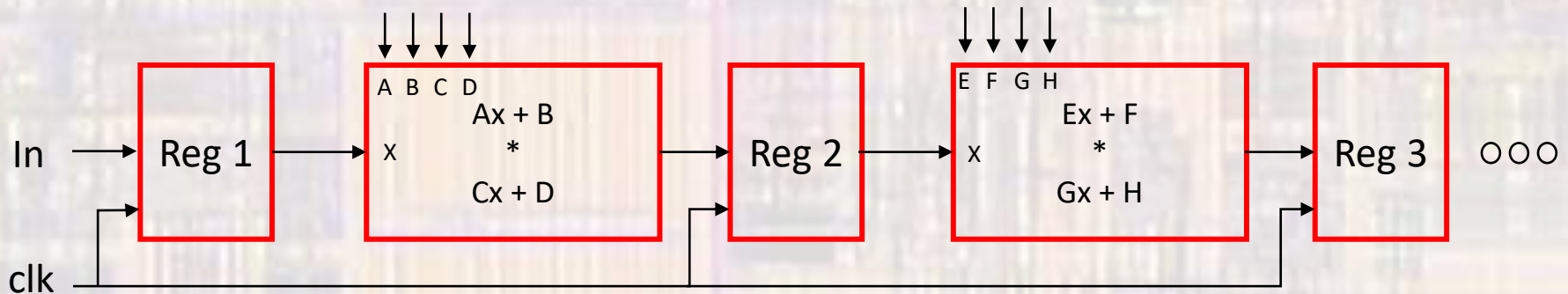

$$4in^4 + 8in^3 - 4in^2 - 8in$$

A B C D E F G H

1 0 1 1 2 0 2 -4

FSMD

- Data Path
 - Real Polynomial generator
 - A-H variable

