



**The Qi Wireless Power Transfer System
Power Class 0 Specification**

Part 4: Reference Designs

**Version 1.2.3
February 2017**

COPYRIGHT

© 2015-2017 by the Wireless Power Consortium. All rights reserved.

The Qi Wireless Power Transfer System, Power Class 0 Specification, *Part 4: Reference Designs* is published by the Wireless Power Consortium, and has been prepared by the members of the Wireless Power Consortium. Reproduction in whole or in part is prohibited without express and prior written permission of the Wireless Power Consortium.

DISCLAIMER

The information contained herein is believed to be accurate as of the date of publication. However, neither the Wireless Power Consortium, nor any member of the Wireless Power Consortium will be liable for any damages, including indirect or consequential, from use of or reliance on the accuracy of this document. For any further explanation of the contents of this document, or in case of any perceived inconsistency or ambiguity of interpretation, or for any information regarding the associated patent license program, contact info@wirelesspowerconsortium.com.

RELEASE HISTORY

Version	Release Date	Description
1.2.1	October 2015	Restructuring and renaming of Wireless Power Transfer System Descriptions.
1.2.2	April 2016	Added new Power Transmitter types A34, B7, and MP-A5; deprecated Power Transmitter types A1, A5, and A9. Addressed technical and editorial issues discovered in version 1.2.1. Made this document accessible to the general public.
1.2.3	February 2017	Added new Power Transmitter types MP-B1, MP-A6, MP-A7, and MP-A8. Relaxed requirements for Shielding materials in the reference designs, and addressed other change requests. See Annex A, History of Changes, for details.

Contents

1	General	6
1.1	Introduction	6
1.2	Scope	6
1.2.1	Current Specification structure (introduced in version 1.2.1)	6
1.2.2	Earlier Specification structure (version 1.2.0 and below)	7
1.3	Main features	7
1.4	Conformance and references	8
1.4.1	Conformance	8
1.4.2	References	8
1.5	Definitions	9
1.6	Acronyms	13
1.7	Symbols	15
1.8	Conventions	16
1.8.1	Cross references	16
1.8.2	Informative text	16
1.8.3	Terms in capitals	16
1.8.4	Units of physical quantities	16
1.8.5	Decimal separator	16
1.8.6	Notation of numbers	17
1.8.7	Bit ordering in a byte	17
1.8.8	Byte numbering	17
1.8.9	Multiple-bit fields	18
1.9	Operators	18
1.9.1	Exclusive-OR	18
1.9.2	Concatenation	18
1.10	Measurement equipment	18
2	Power Transmitter reference designs	19
2.1	Introduction	19
2.2	Baseline Power Profile designs that activate a single Primary Coil at a time	20
2.2.1	Power Transmitter design A1	21
2.2.2	Power Transmitter design A2	22
2.2.3	Power Transmitter design A3	27
2.2.4	Power Transmitter design A4	31

2.2.5	Power Transmitter design A5	37
2.2.6	Power Transmitter design A6	38
2.2.7	Power Transmitter design A7	44
2.2.8	Power Transmitter design A8	48
2.2.9	Power Transmitter design A9	53
2.2.10	Power Transmitter design A10	54
2.2.11	Power Transmitter design A11	60
2.2.12	Power Transmitter design A12	66
2.2.13	Power Transmitter design A13	72
2.2.14	Power Transmitter design A14	77
2.2.15	Power Transmitter design A15	83
2.2.16	Power Transmitter design A16	88
2.2.17	Power Transmitter design A17	94
2.2.18	Power Transmitter design A18	99
2.2.19	Power Transmitter design A19	104
2.2.20	Power Transmitter design A20	110
2.2.21	Power Transmitter design A21	115
2.2.22	Power Transmitter design A22	122
2.2.23	Power Transmitter design A23	128
2.2.24	Power Transmitter design A24	134
2.2.25	Power Transmitter design A25	140
2.2.26	Power Transmitter design A26	146
2.2.27	Power Transmitter design A27	152
2.2.28	Power Transmitter design A28	158
2.2.29	Power Transmitter design A29	164
2.2.30	Power Transmitter design A30	169
2.2.31	Power Transmitter design A31	174
2.2.32	Power Transmitter design A32	179
2.2.33	Power Transmitter design A33	186
2.2.34	Power Transmitter design A34	194
2.3	Baseline Power Profile designs that activate multiple Primary Coils simultaneously	199
2.3.1	Power Transmitter design B1	199
2.3.2	Power Transmitter design B2	207
2.3.3	Power Transmitter design B3	212
2.3.4	Power Transmitter design B4	219
2.3.5	Power Transmitter design B5	228
2.3.6	Power Transmitter design B6	236
2.3.7	Power Transmitter design B7	244

2.4	Extended Power Profile Power Transmitter designs	251
2.4.1	Power Transmitter design MP-A1	251
2.4.2	Power Transmitter design MP-A2	258
2.4.3	Power Transmitter design MP-A3	266
2.4.4	Power Transmitter design MP-A4	272
2.4.5	Power Transmitter design MP-A5	280
2.4.6	Power Transmitter design MP-A6	285
2.4.7	Power Transmitter design MP-A7	291
2.4.8	Power Transmitter design MP-A8	300
2.4.9	Power Transmitter design MP-B1.....	308
3	Power Receiver reference designs (Informative)	315
3.1	Power Receiver example 1 (5W).....	315
3.1.1	Mechanical details.....	315
3.1.2	Electrical details.....	317
3.2	Power Receiver example 2 (5W).....	319
3.2.1	Mechanical details.....	319
3.2.2	Electrical details.....	321
3.3	Power Receiver example 3 (8 W).....	322
3.3.1	Mechanical details.....	322
3.3.2	Electrical details.....	324
3.4	Power Receiver example 4 (15 W).....	325
3.4.1	Mechanical details.....	325
3.4.2	Electrical details.....	327
3.5	Power Receiver example 5 (12 W).....	329
3.5.1	Mechanical details.....	329
3.5.2	Electrical details.....	330
Annex A	History of Changes	332

1 General

1.1 Introduction

The Wireless Power Consortium (WPC) is a worldwide organization that aims to develop and promote global standards for wireless power transfer in various application areas. A first application area is wireless charging of low and medium power devices, such as mobile phones and tablet computers. The Wireless Power Consortium maintains the Qi logo for this application area.

1.2 Scope

This document, *Part 4: Reference Designs*, comprises reference designs for Power Class 0 Base Stations and Mobile Devices. Power Class 0 is the WPC designation for flat-surface devices, such as chargers, mobile phones, tablets, cameras, and battery packs, in the Baseline Power Profile (≤ 5 W) and Extended Power Profile (≤ 15 W).

1.2.1 Current Specification structure (introduced in version 1.2.1)

The Qi Wireless Power Transfer System for Power Class 0 Specification consists of the following documents.

- *Parts 1 and 2: Interface Definitions*
 - *Part 1: Primary Interface Definition*
 - *Part 2: Secondary Interface Definition*
- *Part 3: Compliance Testing*
- ***Part 4: Reference Designs*** (this document)

NOTE WPC publications prior to version 1.2.1 were structured differently, and are listed in Section 1.2.2 below. In particular, the Low Power and Medium Power publications were divided into separate System Description documents. Beginning with version 1.2.1, the Low Power and Medium Power System Descriptions have been merged into the Specification structure shown in this section. Additionally, the terms *Low Power* and *Medium Power* have been replaced in the current Specification by the terms *Baseline Power Profile* and *Extended Power Profile* respectively.

1.2.2 Earlier Specification structure (version 1.2.0 and below)

Before release 1.2.1, the Wireless Power Transfer specification comprised the following documents.

- System Description, Wireless Power Transfer, Volume I: Low Power, Part 1: Interface Definition.
- System Description, Wireless Power Transfer, Volume I: Low Power, Part 2: Performance Requirements.
- System Description, Wireless Power Transfer, Volume I: Low Power, Part 3: Compliance Testing.
- System Description, Qi Wireless Power Transfer, Volume II: Medium Power.

1.3 Main features

- A method of contactless power transfer from a Base Station to a Mobile Device that is based on near field magnetic induction between coils.
- A Baseline Power Profile supporting transfer of up to about 5 W and an Extended Power Profile supporting transfer of up to about 15 W of power using an appropriate Secondary Coil (having a typical outer dimension of around 40 mm).
- Operation at frequencies in the 87...205 kHz range.
- Support for two methods of placing the Mobile Device on the surface of the Base Station:
 - Guided Positioning helps a user to properly place the Mobile Device on the surface of a Base Station that provides power through a single or a few fixed locations of that surface.
 - Free Positioning enables arbitrary placement of the Mobile Device on the surface of a Base Station that can provide power through any location of that surface.
- A simple communications protocol enabling the Mobile Device to take full control of the power transfer.
- Considerable design flexibility for integration of the system into a Mobile Device.
- Very low stand-by power achievable (implementation dependent).

1.4 Conformance and references

1.4.1 Conformance

All provisions in The Qi Wireless Power Transfer System, Power Class 0 Specification are mandatory, unless specifically indicated as recommended, optional, note, example, or informative. Verbal expression of provisions in this Specification follow the rules provided in Annex H of ISO/IEC Directives, Part 2. For clarity, the word “**shall**” indicates a requirement that is to be followed strictly in order to conform to The Qi Wireless Power Transfer System, Power Class 0 Specification, and from which no deviation is permitted. The word “**should**” indicates that among several possibilities one is recommended as particularly suitable, without mentioning or excluding others, or that a certain course of action is preferred but not necessarily required, or that in the negative form a certain possibility or course of action is deprecated but not prohibited. The word “**may**” indicates a course of action permissible within the limits of The Qi Wireless Power Transfer System, Power Class 0 Specification. The word “**can**” indicates a possibility or capability, whether material, physical, or causal.

1.4.2 References

For undated references, the most recently published Specification applies. The most recent WPC publications can be downloaded from <http://www.wirelesspowerconsortium.com>. (See Section 1.2.1 for a list of documents included in The Qi Wireless Power Transfer System for Power Class 0 Specification.) In addition, the following documents are referenced within The Qi Wireless Power Transfer System for Power Class 0 Specification.

- Product Registration Procedure Web page¹ (in the WPC Web site for members, navigate to the Testing & Registration section)
- [Qi Product Registration Manual, Logo Licensee/Manufacturer¹](#)
- [Qi Product Registration Manual, Authorized Test Lab¹](#)
- [Power Receiver Manufacturer Codes¹](#), Wireless Power Consortium
- [The International System of Units \(SI\)](#), Bureau International des Poids et Mesures

¹ Access is restricted and requires signing in to the WPC Web site for members.

1.5 Definitions

Active Area	The part of the Interface Surface of a Base Station or Mobile Device through which a sufficiently high magnetic flux penetrates when the Base Station is providing power to the Mobile Device.
Base Station	A device that is able to provide near field inductive power as specified in The Qi Wireless Power Transfer System, Power Class 0 Specification. A Base Station carries a logo to visually indicate to a user that the Base Station complies with The Qi Wireless Power Transfer System, Power Class 0 Specification.
Baseline Power Profile	The minimum set of features applying to Power Transmitters and Power Receivers that can transfer no more than around 5 W of power.
Communications and Control Unit	The functional part of a Power Transmitter or Power Receiver that controls the power transfer. NOTE With regard to implementation, the Communications and Control Unit may be distributed over multiple subsystems of the Base Station or Mobile Device.
Control Point	The combination of voltage and current provided at the output of the Power Receiver, and other parameters that are specific to a particular Power Receiver implementation.
Detection Unit	The functional part of a Power Transmitter that detects the presence of a Power Receiver on the Interface Surface.
Digital Ping	The application of a Power Signal in order to detect and identify a Power Receiver.
Extended Power Profile	The minimum set of features applying to Power Transmitters and Power Receivers that can transfer power above 5 W.
Free Positioning	A method of positioning a Mobile Device on the Interface Surface of a Base Station that does not require the user to align the Active Area of the Mobile Device to the Active Area of the Base Station.
Foreign Object	Any object that is positioned on the Interface Surface of a Base Station, but is not part of a Mobile Device.
Foreign Object Detection	A process that a Power Transmitter or Power Receiver executes in order to determine if a Foreign Object is present on the Interface Surface.

Friendly Metal	A part of a Base Station or a Mobile Device in which a Power Transmitter's magnetic field can generate eddy currents.
Guaranteed Power	<p>The amount of output power of an appropriate reference Power Receiver that the Power Transmitter ensures is available at any time during the power transfer phase. For Power Transmitters that comply with the Baseline Power Profile, the reference is TPR#1A, which is defined in <i>Part 3: Compliance Testing</i>. For Power Transmitters that comply with the Extended Power Profile, the reference is TPR#MP1B, which is also defined in <i>Part 3: Compliance Testing</i>.</p> <p>Depending on the context, <i>Guaranteed Power</i> can refer to the Guaranteed Power value contained in the Power Transfer Contract, or it can refer to the Guaranteed Power Value field contained in the Power Transmitter Capability Packet.</p>
Guided Positioning	A method of positioning a Mobile Device on the Interface Surface of a Base Station that provides the user with feedback to properly align the Active Area of the Mobile Device to the Active Area of the Base Station.
Interface Surface	The flat part of the surface of a Base Station that is closest to the Primary Coil(s), or the flat part of the surface of the Mobile Device that is closest to the Secondary Coil.
Maximum Power	The maximum amount of power that a Power Receiver expects to provide at its output throughout the power transfer phase. The Maximum Power serves as a scaling factor for the Received Power Values that a Power Receiver reports in its Received Power Packets.
Mobile Device	A device that is able to consume near field inductive power as specified in The Qi Wireless Power Transfer System, Power Class 0 Specification. A Mobile Device carries a logo to visually indicate to a user that the Mobile Device complies with the Specification.
Operating Frequency	The oscillation frequency of the Power Signal.
Operating Point	The combination of the frequency, duty cycle, and amplitude of the voltage that is applied to the Primary Cell.
Packet	A data structure for communicating a message from a Power Receiver to a Power Transmitter or vice versa. A Packet consists of a preamble, a header byte, a message, and a checksum. A Packet is named after the kind of message that it contains.

Potential Power	The amount of output power by an appropriate reference Power Receiver that the Power Transmitter can make available during the power transfer phase. For Power Transmitters that comply with the Baseline Power Profile, the reference is TPR#1A, which is defined in <i>Part 3: Compliance Testing</i> . For Power Transmitters that comply with the Extended Power Profile, the reference is TPR#MP1B, which is also defined in <i>Part 3: Compliance Testing</i> .
Power Conversion Unit	The functional part of a Power Transmitter that converts electrical energy to a Power Signal.
Power Factor	The ratio of the active power consumed and the apparent power drawn. The active power is expressed in watts. The apparent power typically is expressed in volt-amperes (VA).
Power Pick-up Unit	The functional part of a Power Receiver that converts a Power Signal to electrical energy.
Power Receiver	The subsystem of a Mobile Device that acquires near field inductive power and controls its availability at its output, as defined in The Qi Wireless Power Transfer System, Power Class 0 Specification. For this purpose, the Power Receiver communicates its power requirements to the Power Transmitter.
Power Signal	The oscillating magnetic flux that is enclosed by a Primary Cell and possibly a Secondary Coil.
Power Transfer Contract	A set of boundary conditions on the parameters that characterize the power transfer from a Power Transmitter to a Power Receiver. Violation of any of these boundary conditions causes the power transfer to abort.
Power Transmitter	The subsystem of a Base Station that generates near field inductive power and controls its transfer to a Power Receiver, as defined in The Qi Wireless Power Transfer System, Power Class 0 Specification.
Primary Cell	A single Primary Coil or a combination of Primary Coils that are used to provide a sufficiently high magnetic flux through the Active Area.
Primary Coil	A component of a Power Transmitter that converts electric current to magnetic flux.

Received Power	The total amount of power dissipated inside a Mobile Device, due to the magnetic field generated by a Power Transmitter. The Received Power includes the power that the Power Receiver makes available at its output for use by the Mobile Device, any power that the Power Receiver uses for its own purposes, as well as any power that is lost within the Mobile Device.
Reference Quality Factor	The quality-factor of Test Power Transmitter #MP1's Primary Coil at an Operating Frequency of 100 kHz, with a Power Receiver positioned on the Interface Surface and no Foreign Object nearby.
Response	A sequence of eight consecutive bi-phase modulated bits transmitted by a Power Transmitter in response to a request from a Power Receiver.
Secondary Coil	The component of a Power Receiver that converts magnetic flux to electromotive force.
Shielding	A component in the Power Transmitter that restricts magnetic fields to the appropriate parts of the Base Station, or a component in the Power Receiver that restricts magnetic fields to the appropriate parts of the Mobile Device.
Specification	The set of documents, Parts 1 through 4, that comprise The Qi Wireless Power Transfer System, Power Class 0 Specification (see Section 1.2.1).
Transmitted Power	The total amount of power generated by the Power Transmitter that is dissipated from the magnetic field outside the enclosure of the Base Station. The Power Transmitter typically determines the Transmitted Power by measuring the amount of power it draws from its power source and subtracting an estimate of the losses inside the enclosure of the Base Station.
WPID	A 48-bit number that uniquely identifies a Qi-compliant device.

1.6 Acronyms

AC	Alternating Current
ACK	Acknowledge
AWG	American Wire Gauge
BPP	Baseline Power Profile
BSUT	Base Station Under Test
CEP	Control Error Packet
DC	Direct Current
DCR	Direct Current Resistance
EM	Electro Magnetic
EMC	Electro Magnetic Compatibility
EMF	Electro Magnetic Fields
EPP	Extended Power Profile
EPT	End Power Transfer
ESR	Equivalent Series Resistance
FET	Field Effect Transistor
FOD	Foreign Object Detection
FSK	Frequency-Shift Keying
GPV	Guaranteed Power Value
LSB	Least Significant Bit
MSB	Most Significant Bit
MDUT	Mobile Device Under Test
N.A.	Not Applicable
NAK	Not-Acknowledge
ND	Not-Defined

PID	Proportional Integral Differential
PRx	Power Receiver
PPV	Potential Power Value
PTC-GP	Power Transfer Contract – Guaranteed Power
PTx	Power Transmitter
RMS	Root Mean Square
TP	Transmitter Power
TPR	Test Power Receiver
UART	Universal Asynchronous Receiver Transmitter
USB	Universal Serial Bus
WPID	Wireless Power Identifier

1.7 Symbols

C_d	Capacitance parallel to the Secondary Coil [nF]
C_m	Capacitance in the impedance matching network [nF]
C_p	Capacitance in series with the Primary Coil [nF]
C_s	Capacitance in series with the Secondary Coil [nF]
d	Duty cycle of the inverter in the Power Transmitter
d_s	Distance between a coil and its Shielding [mm]
d_z	Distance between a coil and the Interface Surface [mm]
f_{CLK}	Communications bit rate [kHz]
f_d	Resonant detection frequency [kHz]
f_{op}	Operating Frequency [kHz]
f_s	Secondary resonance frequency [kHz]
I_m	Primary Coil current modulation depth [mA]
I_o	Power Receiver output current [mA]
I_p	Primary Coil current [mA]
L_m	Inductance in the impedance matching network [μ H]
L_p	Primary Coil self inductance [μ H]
L_s	Secondary Coil self inductance (Mobile Device away from Base Station) [μ H]
L'_s	Secondary Coil self inductance (Mobile Device on top of Base Station) [μ H]
P_{FO}	Power loss that results in heating of a Foreign Object [W]
P_{PR}	Total amount of power received through the Interface Surface [W]
P_{PT}	Total amount of power transmitted through the Interface Surface [W]
Q	Quality factor
t_{delay}	Power Control Hold-off Time [ms]

t_{CLK}	Communications clock period [μs]
t_{T}	Maximum transition time of the communications [μs]
V_{r}	Rectified voltage [V]
V_{o}	Power Receiver output voltage [V]

1.8 Conventions

This section defines the notations and conventions used in The Qi Wireless Power Transfer System, Power Class 0 Specification.

1.8.1 Cross references

Unless indicated otherwise, cross references to sections include the sub sections contained therein.

1.8.2 Informative text

Informative text is set in italics, unless the complete Section is marked as informative.

1.8.3 Terms in capitals

Terms having a specific meaning in the context of The Qi Wireless Power Transfer System, Power Class 0 Specification are capitalized and defined in Section 7.

1.8.4 Units of physical quantities

Physical quantities are expressed in units of the International System of Units.

1.8.5 Decimal separator

The decimal separator is a period.

1.8.6 Notation of numbers

- Real numbers are represented using the digits 0 to 9, a decimal point, and optionally an exponential part. In addition, a positive and/or negative tolerance indicator may follow a real number. Real numbers that do not include an explicit tolerance indicator, are accurate to half the least significant digit that is specified.

EXAMPLE A specified value of $1.23_{-0.02}^{+0.01}$ comprises the range from 1.21 through 1.24; a specified value of $1.23^{+0.01}$ comprises the range from 1.23 through 1.24; a specified value of $1.23_{-0.02}$ comprises the range from 1.21 through 1.23; a specified value of 1.23 comprises the range from 1.225 through 1.234999...; and a specified value of $1.23 \pm 10\%$ comprises the range from 1.107 through 1.353.

- Integer numbers in decimal notation are represented using the digits 0 to 9.
- Integer numbers in hexadecimal notation are represented using the hexadecimal digits 0 to 9 and A to F, and are prefixed by “0x” unless explicitly indicated otherwise.
- Single bit values are represented using the words ZERO and ONE.
- Integer numbers in binary notation and bit patterns are represented using sequences of the digits 0 and 1, which are enclosed in single quotes (e.g. ‘01001’). In a sequence of n bits, the most significant bit (MSB) is bit b_{n-1} and the least significant bit (LSB) is bit b_0 . The most significant bit is shown on the left-hand side.
- Numbers that are shown between parentheses are informative.

1.8.7 Bit ordering in a byte

The graphical representation of a byte is such that the most significant bit is on the left, and the least significant bit is on the right. Figure 1 defines the bit positions in a byte.

Figure 1. Bit positions in a byte

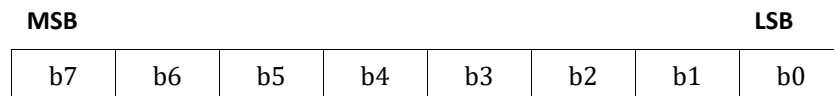

1.8.8 Byte numbering

The bytes in a sequence of n bytes are referred to as B_0, B_1, \dots, B_{n-1} . Byte B_0 corresponds to the first byte in the sequence; byte B_{n-1} corresponds to the last byte in the sequence. The graphical representation of a byte sequence is such that B_0 is at the upper left-hand side, and byte B_{n-1} is at the lower right-hand side.

1.8.9 Multiple-bit fields

Multiple-bit fields are used in the ID Packet. Unless indicated otherwise, a multiple-bit field in a data structure represents an unsigned integer value. In a multiple-bit field that spans multiple bytes, the MSB of the multiple-bit field is located in the byte with the lowest address, and the LSB of the multiple-bit field is located in the byte with the highest address.

NOTE Figure 2 provides an example of a 6-bit field that spans two bytes.

Figure 2. Example of multiple-bit field

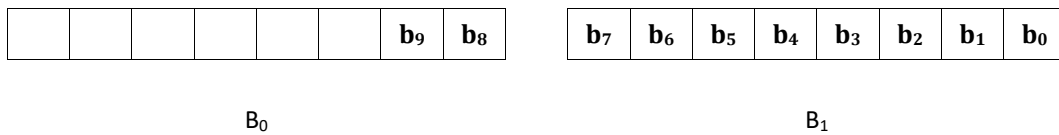

1.9 Operators

This section defines less-commonly used operators that are used in The Qi Wireless Power Transfer System, Power Class 0 Specification. The commonly used operators have their usual meaning.

1.9.1 Exclusive-OR

The symbol ‘ \oplus ’ represents the exclusive-OR operation.

1.9.2 Concatenation

The symbol ‘||’ represents the concatenation of two bit strings. In the resulting concatenated bit string, the MSB of the right-hand side operand directly follows the LSB of the left-hand side operand.

1.10 Measurement equipment

All measurements shall be performed using equipment that has a resolution of at least one quarter of the precision of the quantity that is to be measured, unless indicated otherwise.

EXAMPLE “ $t_{\text{start}}=15 \text{ ms}$ ” means that the equipment shall be precise to 0.25 ms.

2 Power Transmitter reference designs

2.1 Introduction

The Power Transmitter designs that are defined in this *Part 4: Reference Designs*, are grouped in two basic types.

Type A Power Transmitter designs have one or more Primary Coils. They activate a single Primary Coil at a time and therefore employ a single Primary Cell that coincides with the activated Primary Coil. In addition, type A Power Transmitter designs include means to realize proper alignment of the Primary Coil and Secondary Coil. Depending on this means, a type A Power Transmitter enables either Guided Positioning or Free Positioning.

Type B Power Transmitter designs have an array of Primary Coils. All type B Power Transmitters enable Free Positioning. For that purpose, type B Power Transmitters can activate one or more Primary Coils from the array to realize a Primary Cell at different positions across the Interface Surface.

A Power Transmitter serves only one Power Receiver at a time only. However, a Base Station may contain several Power Transmitters in order to serve multiple Mobile Devices simultaneously. Note that multiple type B Power Transmitters may share (parts of) the multiplexer and array of Primary Coils (see Section 3.3.1.3).

NOTE Power Receivers that use thin magnetic Shielding have been found to experience reduced performance on Power Transmitters that contain a permanent magnet in or near the Active Area. Such Power Receivers may exhibit, for example, less positioning freedom and/or a longer charging time. For this reason, Power Transmitter designs A1, A5, and A9 have been deprecated as of version 1.2 of the Qi Power Class 0 Specification.

The remaining Power Transmitter designs provided in this part 4 of the Qi Power Class 0 Specification do not use a permanent magnet. Product implementations based on these designs that include a permanent magnet in or near the Active Area are not compliant with this specification.

IMPORTANT Most countries and regions restrict electro-magnetic emissions across the frequency spectrum. Products have to comply with these regulations when they are sold for use in those countries and regions. Meeting the applicable requirements can be more or less difficult depending on the Power Transmitter design being used in the product. In some countries or regions, it can be economically unfeasible to use some of the Power Transmitter designs defined in this *Part 4: Reference Designs*.

2.2 Baseline Power Profile designs that activate a single Primary Coil at a time

This Section 2.2 defines all type A Power Transmitter designs in the Baseline Power Profile. In addition to the definitions in this section, each Power Transmitter design shall implement the relevant parts of the protocols defined in the *Power Transmitter to Power Receiver communications interface* section in *Parts 1 and 2: Interface Definitions*.

2.2.1 Power Transmitter design A1

Power Transmitter design A1 has been deprecated. For further information, see the note in Section 2.1.

2.2.2 Power Transmitter design A2

Power Transmitter design A2 enables Free Positioning. Figure 3 illustrates the functional block diagram of this design, which consists of three major functional units, namely a Power Conversion Unit, a Detection Unit, and a Communications and Control Unit.

Figure 3. Functional block diagram of Power Transmitter design A2

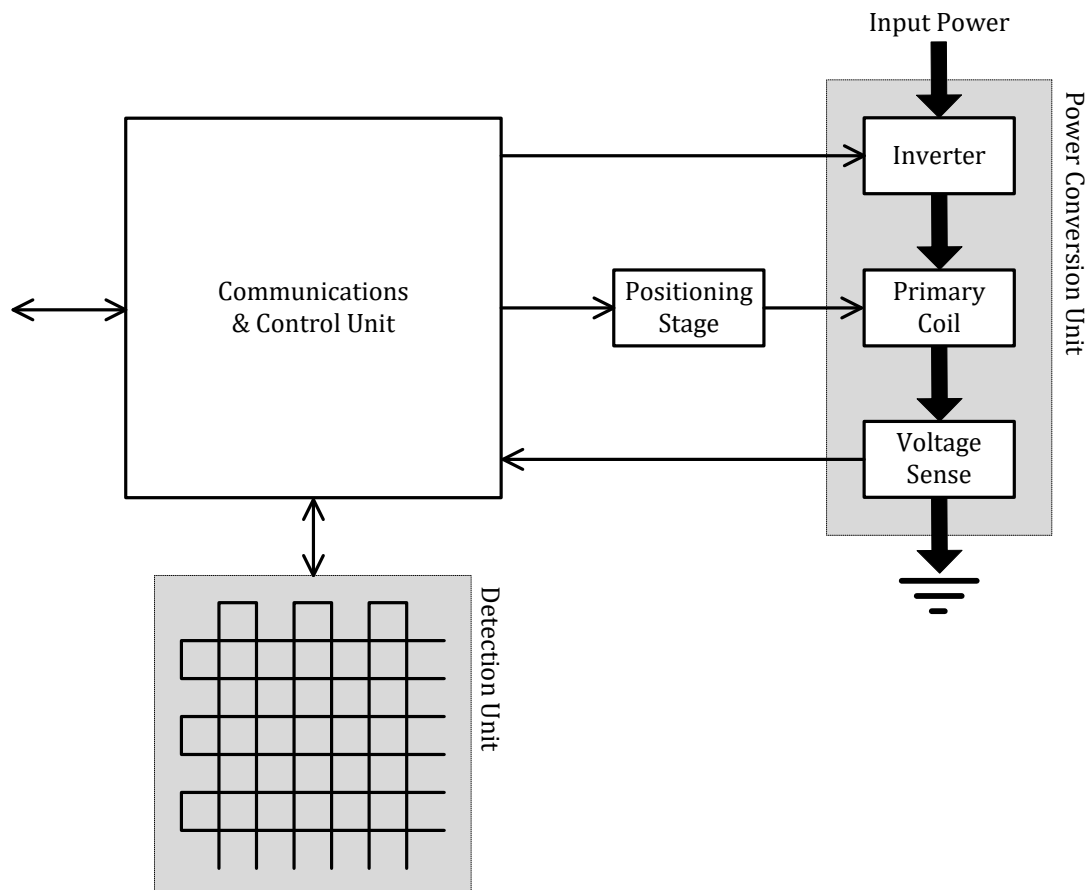

The Power Conversion Unit on the right-hand side of Figure 3 and the Detection Unit of the bottom of Figure 3 comprise the analog parts of the design. The Power Conversion Unit is similar to the Power Conversion Unit of Power Transmitter design A10. The inverter converts the DC input to an AC waveform that drives a resonant circuit, which consists of the Primary Coil plus a series capacitor. The Primary Coil is mounted on a positioning stage to enable accurate alignment of the Primary Coil to the Active Area of the Mobile Device. Finally, the voltage sense monitors the Primary Coil voltage.

The Communications and Control Unit on the left-hand side of Figure 3 comprises the digital logic part of the design. This unit is similar to the Communications and Control Unit of Power Transmitter design A10. The Communications and Control Unit receives and decodes messages from the Power Receiver, executes the relevant power control algorithms and protocols, and drives the input voltage of the AC waveform to control the power transfer. In addition, the Communications and Control Unit drives the positioning stage and operates the Detection Unit. The Communications and Control Unit also interfaces with other subsystems of the Base Station, e.g. for user interface purposes.

The Detection Unit determines the approximate location of objects and/or Power Receivers on the Interface Surface. This version of *Part 4: Reference Designs* does not specify a particular detection method. However, it is recommended that the Detection Unit exploits the resonance in the Power Receiver at the detection frequency f_d (see *Parts 1 and 2: Interface Definitions*). The reason is that this approach minimizes movements of the Primary Coil, because the Power Transmitter does not need to attempt to identify objects that do not respond at this resonant frequency. The *Moving Primary Coil based Free Positioning* section in *Parts 1 and 2: Interface Definitions* provides an example resonant detection method.

2.2.2.1 Mechanical details

Power Transmitter design A2 includes a single Primary Coil as defined in Section 2.2.2.1.1, Shielding as defined in Section 2.2.2.1.2, an Interface Surface as defined in Section 2.2.2.1.3, and a positioning stage as defined in Section 2.2.2.1.4

2.2.2.1.1 Primary Coil

The Primary Coil is of the wire-wound type, and consists of litz wire having 30 strands of 0.1 mm diameter, or equivalent. As shown in Figure 4, the Primary Coil has a circular shape and consists of multiple layers. All layers are stacked with the same polarity. Table 1 lists the dimensions of the Primary Coil.

Figure 4. Primary Coil of Power Transmitter design A2

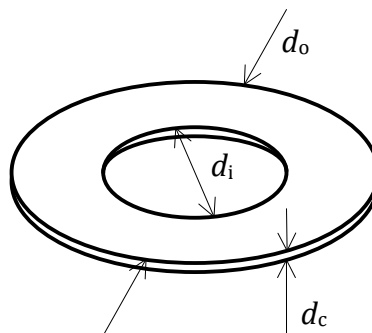

Table 1. Primary Coil parameters of Power Transmitter design A2

Parameter	Symbol	Value
Outer diameter	d_o	$40^{\pm 1}$ mm
Inner diameter	d_i	$19^{\pm 1}$ mm
Thickness	d_c	$2^{+0.2}$ mm
Number of turns per layer	N	10
Number of layers	-	2

2.2.2.1.2 Shielding

As shown in Figure 5, Shielding protects the Base Station from the magnetic field that is generated in the Primary Coil. The Shielding should be Ni-Zn or Mn-Zn ferrite and should be at least 0.2 mm thick. The Shielding extends to at least 2 mm beyond the outer diameter of the Primary Coil, and is placed below the Primary Coil at a distance of at most $d_s = 0.1$ mm.

Figure 5. Primary Coil assembly of Power Transmitter design A2

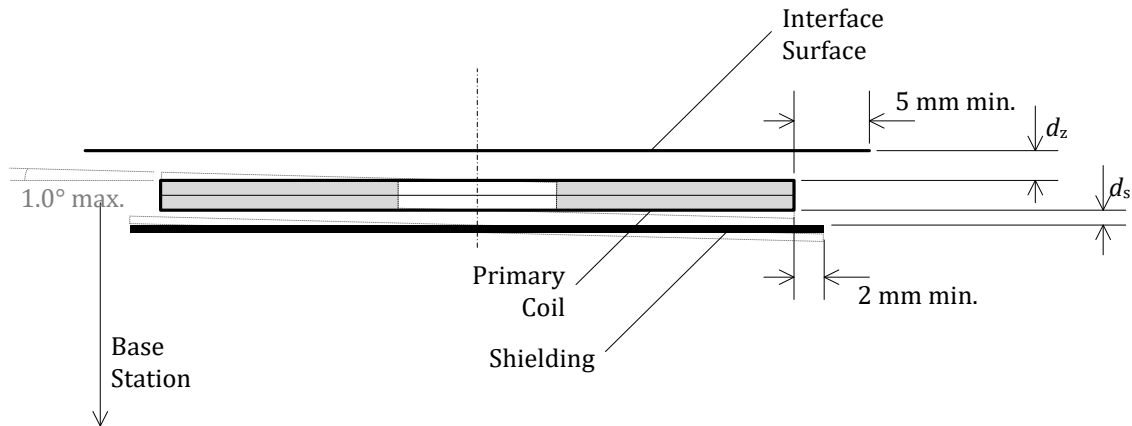

2.2.2.1.3 Interface Surface

As shown in Figure 5, the distance from the Primary Coil to the Interface Surface of the Base Station is $d_z = 2.5^{+0.5}_{-0}$ mm, across the top face of the Primary Coil. In addition, the Interface Surface of the Base Station extends at least 5 mm beyond the outer diameter of the Primary Coil.

2.2.2.1.4 Positioning stage

The positioning stage shall have a resolution of 0.1 mm or better in each of the two orthogonal directions parallel to the Interface Surface.

2.2.2.2 Electrical details

As shown in Figure 6, Power Transmitter design A2 uses a full-bridge inverter to drive the Primary Coil and a series capacitance. At the fixed Operating Frequency of 140 kHz, the assembly of Primary Coil and Shielding has a self inductance $L_p = 24^{\pm 1} \mu\text{H}$. The value of the series capacitance is $C_p = 200^{\pm 5\%} \text{nF}$.

NOTE Near resonance, the voltage developed across the series capacitance can reach levels up to 50 V pk-pk.

Power Transmitter design A2 uses the input voltage to the full-bridge inverter to control the amount of power that is transferred. For this purpose, the input voltage range is 3...12 V, where a lower input voltage results in the transfer of a lower amount of power. In order to achieve a sufficiently accurate adjustment of the power that is transferred, a type A2 Power Transmitter shall be able to control the input voltage with a resolution of 50 mV or better.

When a type A2 Power Transmitter first applies a Power Signal (Digital Ping; see *Parts 1 and 2: Interface Definitions*), it shall use an initial input voltage of 8 V.

Figure 6. Electrical diagram (outline) of Power Transmitter design A2

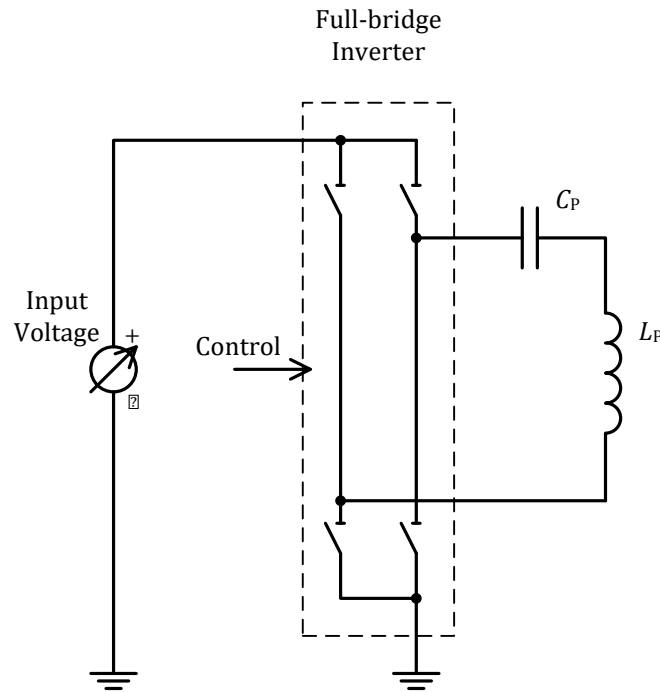

Control of the power transfer shall proceed using the PID algorithm, which is defined in the *Power transfer control* section in *Parts 1 and 2: Interface Definitions*. The controlled variable $v^{(i)}$ introduced in the definition of that algorithm represents the input voltage to the full-bridge inverter. In order to guarantee sufficiently accurate power control, a type A2 Power Transmitter shall determine the amplitude of the

Primary Cell voltage—which is equal to the Primary Coil voltage—with a resolution of 5 mV or better. Finally, Table 2 provides the values of several parameters that are used in the PID algorithm.

Table 2. PID parameters for voltage control

Parameter	Symbol	Value	Unit
Proportional gain	K_p	1	mA^{-1}
Integral gain	K_i	0	$\text{mA}^{-1}\text{ms}^{-1}$
Derivative gain	K_d	0	mA^{-1}ms
Integral term limit	M_I	N.A.	N.A.
PID output limit	M_{PID}	1,500	N.A.
Scaling factor	S_v	-0.5	mV

2.2.3 Power Transmitter design A3

Power Transmitter design A3 enables Free Positioning, and has a design similar to Power Transmitter design A2. See Section 0 for an overview.

2.2.3.1 Mechanical details

Power Transmitter design A3 includes a single Primary Coil as defined in Section 2.2.3.1.1, Shielding as defined in Section 2.2.3.1.2, an Interface Surface as defined in Section 2.2.3.1.3, and a positioning stage as defined in Section 2.2.3.1.4.

2.2.3.1.1 Primary Coil

The Primary Coil is of the wire-wound type, and consists of litz wire having 11 strands of 0.20 mm diameter, or equivalent. As shown in Figure 7, the Primary Coil has a circular shape and consists of a single layer. Table 3 lists the dimensions of the Primary Coil.

Figure 7. Primary Coil of Power Transmitter design A3

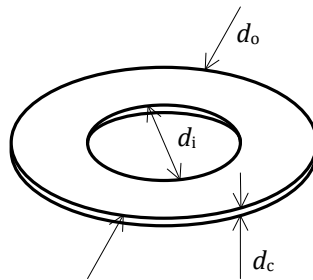

Table 3. Primary Coil parameters of Power Transmitter design A3

Parameter	Symbol	Value
Outer diameter	d_o	$33^{\pm 1}$ mm
Inner diameter	d_i	$10^{\pm 0.2}$ mm
Thickness	d_c	$1.8^{\pm 0.4}$ mm
Number of turns per layer	N	25
Number of layers	-	1

2.2.3.1.2 Shielding

As shown in Figure 8, Shielding protects the Base Station from the magnetic field that is generated in the Primary Coil. The Shielding should be Ni-Zn or Mn-Zn ferrite and should be at least 0.6 mm thick. The Shielding extends to at least 1 mm beyond the outer diameter of the Primary Coil, and is placed below the Primary Coil at a distance of at most $d_s = 0.4$ mm.

Figure 8. Primary Coil assembly of Power Transmitter design A3

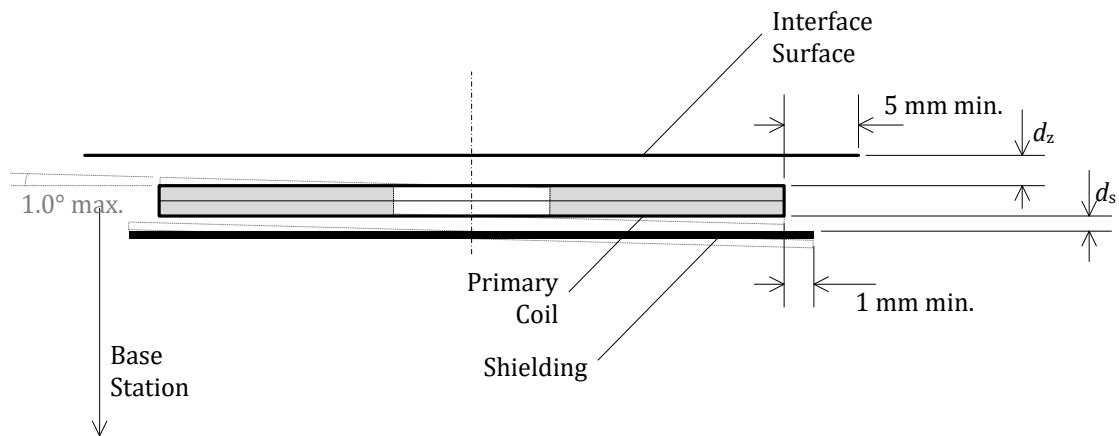

2.2.3.1.3 Interface Surface

As shown in Figure 8, the distance from the Primary Coil to the Interface Surface of the Base Station is $d_z = 2.5^{+0.5}_0$ mm, across the top face of the Primary Coil. In addition, the Interface Surface of the Base Station extends at least 5 mm beyond the outer diameter of the Primary Coil.

2.2.3.1.4 Positioning stage

The positioning stage shall have a resolution of 0.1 mm or better in each of the two orthogonal directions parallel to the Interface Surface.

2.2.3.2 Electrical details

As shown in Figure 9, Power Transmitter design A3 uses a full-bridge inverter to drive the Primary Coil and a series capacitance. At an Operating Frequency range between 105 kHz and 140 kHz, the assembly of Primary Coil and Shielding has a self inductance $L_p = 16.5^{\pm 10\%} \mu\text{H}$. The value of the series capacitance is $C_p = 180^{\pm 5\%} \text{nF}$.

NOTE Near resonance, the voltage developed across the series capacitance can reach levels up to 100 V pk-pk.

Power Transmitter design A3 uses the input voltage to the full-bridge inverter to control the amount of power that is transferred. For this purpose, the input voltage range is 3...12 V, where a lower input voltage results in the transfer of a lower amount of power. In order to achieve a sufficiently accurate adjustment of the power that is transferred, a type A3 Power Transmitter shall be able to control the input voltage with a resolution of 50 mV or better.

When a type A3 Power Transmitter first applies a Power Signal (Digital Ping; see *Parts 1 and 2: Interface Definitions*), it shall use an initial input voltage of 6 V. It is recommended that the Power Transmitter uses an Operating Frequency of 140 kHz when first applying the Power Signal. If the Power Transmitter does not receive a Signal Strength Packet from the Power Receiver, the Power Transmitter shall remove the Power Signal as defined in Section *Parts 1 and 2: Interface Definitions*. The Power Transmitter may reapply the Power Signal multiple times at other—consecutively lower—Operating Frequencies within the range specified above, until the Power Transmitter receives a Signal Strength Packet containing an appropriate Signal Strength Value.

Figure 9. Electrical diagram (outline) of Power Transmitter design A3

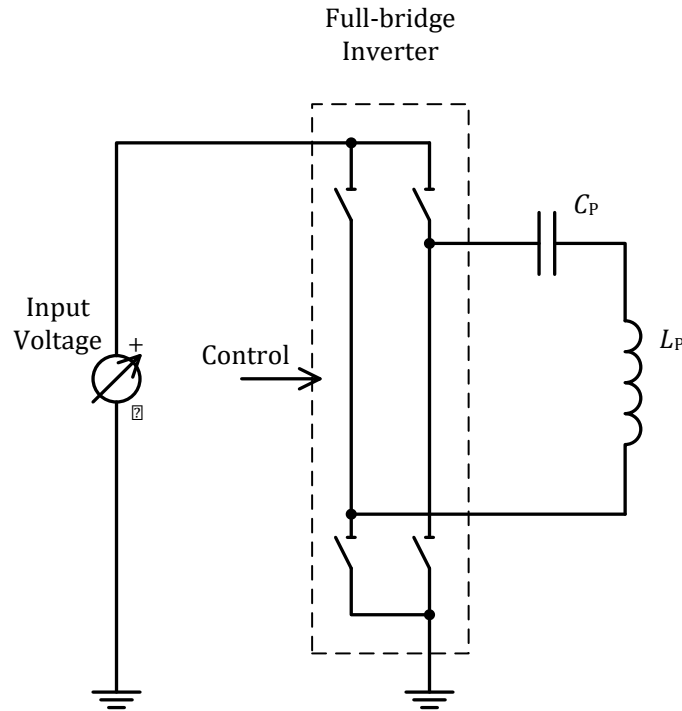

Control of the power transfer shall proceed using the PID algorithm, which is defined in *Parts 1 and 2: Interface Definitions*. The controlled variable $v^{(i)}$ introduced in the definition of that algorithm represents the input voltage to the full-bridge inverter. In order to guarantee sufficiently accurate power control, a type A3 Power Transmitter shall determine the amplitude of the Primary Cell voltage—which is equal to the Primary Coil voltage—with a resolution of 5 mV or better. Finally, Table 4 provides the values of several parameters, which are used in the PID algorithm.

Table 4. PID parameters for voltage control

Parameter	Symbol	Value	Unit
Proportional gain	K_p	1	mA^{-1}
Integral gain	K_i	0	$\text{mA}^{-1}\text{ms}^{-1}$
Derivative gain	K_d	0	mA^{-1}ms
Integral term limit	M_I	N.A.	N.A.
PID output limit	M_{PID}	1,500	N.A.
Scaling factor	S_v	-0.5	mV

2.2.4 Power Transmitter design A4

Power Transmitter design A4 enables Free Positioning. Figure 10 illustrates the functional block diagram of this design, which consists of two major functional units, namely a Power Conversion Unit and a Communications and Control Unit.

Figure 10. Functional block diagram of Power Transmitter design A4

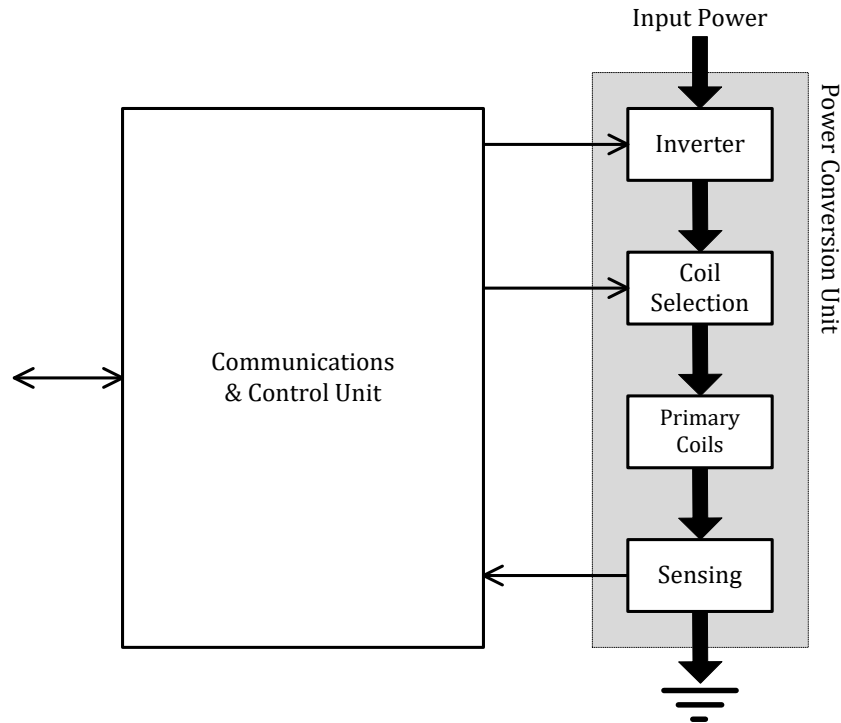

The Power Conversion Unit on the right-hand side of Figure 10 and the Detection Unit of the bottom of Figure 10 comprise the analog parts of the design. The inverter converts the DC input to an AC waveform that drives a resonant circuit, which consists of the selected Primary Coil plus a series capacitor. The selected Primary Coil is one from two partially overlapping Primary Coils, as appropriate for the position of the Power Receiver relative to the two Primary Coils. Selection of the Primary Coil proceeds by the Power Transmitter attempting to establish communication with a Power Receiver using either Primary Coil. Finally, the voltage sense monitors the Primary Coil voltage and current.

The Communications and Control Unit on the left-hand side of Figure 10 comprises the digital logic part of the design. The Communications and Control Unit receives and decodes messages from the Power Receiver, configures the Coil Selection block to connect the appropriate Primary Coil, executes the relevant power control algorithms and protocols, and drives the input voltage of the AC waveform to control the power transfer. The Communications and Control Unit also interfaces with other subsystems of the Base Station, e.g. for user interface purposes.

2.2.4.1 Mechanical details

Power Transmitter design A4 includes two Primary Coils as defined in Section 2.2.4.1.1, Shielding as defined in Section 2.2.4.1.2, and an Interface Surface as defined in Section 2.2.4.1.3.

2.2.4.1.1 Primary Coil

The Primary Coils are of the wire-wound type, and consists of litz wire having 115 strands of 0.08 mm diameter, or equivalent. As shown in Figure 11, a Primary Coil has a racetrack-like shape and consists of a single layer. Table 5 lists the dimensions of a Primary Coil.

Figure 11. Primary Coil of Power Transmitter design A4

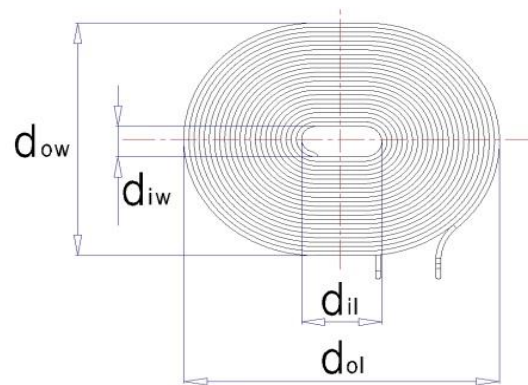
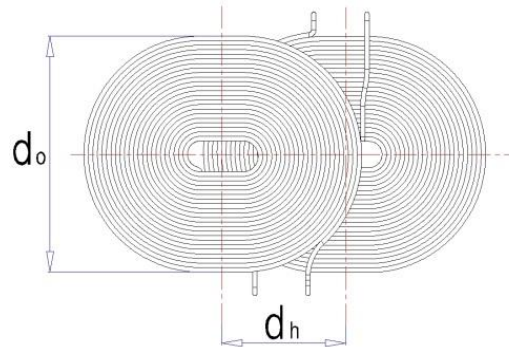

Table 5. Primary Coil parameters of Power Transmitter design A4

Parameter	Symbol	Value
Outer length	d_{ol}	$70^{\pm 0.5}$ mm
Inner length	d_{il}	$15^{\pm 0.5}$ mm
Outer width	d_{ow}	$59^{\pm 0.5}$ mm
Inner width	d_{iw}	$4^{\pm 0.5}$ mm
Thickness	d_c	$1.15^{\pm 0.05}$ mm
Number of turns per layer	N	23.5
Number of layers	-	1

Power Transmitter design A4 contains two Primary Coils, which are mounted in a Shielding block (see Section 2.2.4.1.2) with their long axes coincident, and a displacement of $d_h = 41^{\pm 0.5}$ mm between their centers. See Figure 12.

Figure 12. Dual Primary Coils (top view)



2.2.4.1.2 Shielding

As shown in Figure 13, Shielding protects the Base Station from the magnetic field that is generated in the Primary Coils. The Shielding should be Ni-Zn or Mn-Zn ferrite and should be at least 5.0 mm thick.

The top face of the Shielding block is aligned with the top face of the Primary Coils, such that the Shielding surrounds the Primary Coils on all sides except for the top face. In addition, the Shielding extends to at least 2.5 mm beyond the outer edge of the Primary Coils.

Figure 13. Primary Coil assembly of Power Transmitter design A4

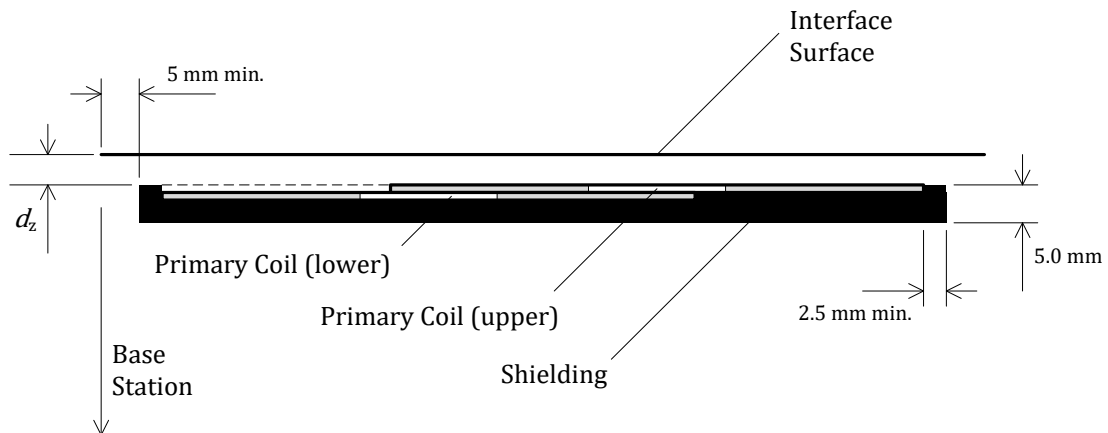

2.2.4.1.3 Interface Surface

As shown in Figure 13, the distance from the Primary Coil to the Interface Surface of the Base Station is $d_z = 2.0^{\pm 0.5}$ mm, across the top face of the Primary Coil. In addition, the Interface Surface of the Base Station extends at least 5 mm beyond the outer diameter of the Primary Coil.

2.2.4.1.4 Separation between multiple Power transmitters

In a Base Station that contains multiple type A4 Power Transmitters, the Primary Coil assemblies of any pair of Power Transmitter shall not overlap.

NOTE The two Primary Coils within an assembly do overlap as defined in Section 2.2.4.1.1.

2.2.4.2 Electrical details

As shown in Figure 14, Power Transmitter design A4 uses a full-bridge inverter to drive the Primary Coils and a series capacitance. In addition, Power Transmitter design A4 shall operate coil selection switches SWu and SWl such that only a single Primary Coil is connected to the inverter.

Within the Operating Frequency range of 110...180 kHz, each Primary Coil in the assembly of Primary Coils and Shielding has a self inductance $L_p = 24^{\pm 0.5}$ μ H. The value of the series capacitance is $C_p = 100^{\pm 5\%}$ nF. The input voltage to the full-bridge inverter is 5...11 V.

NOTE Near resonance, the voltage developed across the series capacitance can reach levels up to 40 V pk-pk.

Power Transmitter design A4 uses the Operating Frequency and the input voltage to the full-bridge inverter to control the amount of power that is transferred. In order to achieve a sufficiently accurate adjustment of the power that is transferred, a type A4 Power Transmitter shall be able to control the frequency with a resolution of 0.5 kHz, and the input voltage with a resolution of 50 mV or better.

When a type A4 Power Transmitter first applies a Power Signal (Digital Ping; see *Part 4: Reference Designs*), the Power Transmitter shall use an Operating Frequency of 130 kHz, and an input voltage of 8 V. If the Power Transmitter does not receive a Signal Strength Packet from the Power Receiver, the Power Transmitter shall remove the Power Signal as defined in *Part 4: Reference Designs*. The Power Transmitter may reapply the Power Signal multiple times at an Operating Frequency of 130 kHz using consecutively higher input voltages within the range specified above, until the Power Transmitter receives a Signal Strength Packet containing an appropriate Signal Strength Value.

Figure 14. Electrical diagram (outline) of Power Transmitter design A4

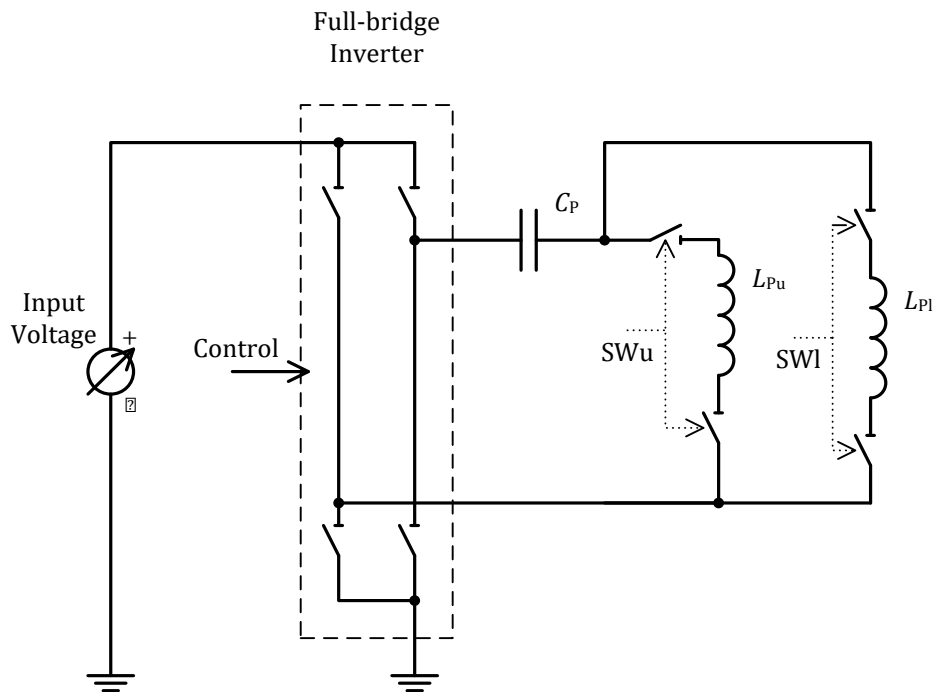

Control of the power transfer shall proceed using the PID algorithm, which is defined in *Parts 1 and 2: Interface Definitions*. The controlled variable $v^{(i)}$ introduced in the definition of that algorithm represents Operating Frequency as well as the input voltage to the full-bridge inverter. It is recommended that control of the power occurs primarily by means of adjustments to the Operating Frequency, and that voltage adjustments are made only at the boundaries of the Operating Frequency range. In order to guarantee sufficiently accurate power control, a type A4 Power Transmitter shall determine the amplitude of the Primary Coil current with a resolution of 5 mA or better. Finally, Table 6 and Table 7 provide the values of several parameters, which are used in the PID algorithm.

Table 6. PID parameters for Operating Frequency control

Parameter	Symbol	Value	Unit
Proportional gain	K_p	1	mA^{-1}
Integral gain	K_i	0	$\text{mA}^{-1}\text{ms}^{-1}$
Derivative gain	K_d	0	mA^{-1}ms
Integral term limit	M_I	N.A.	N.A.
PID output limit	M_{PID}	20,000	N.A.
Scaling factor	S_v	1.0	Hz

Table 7. PID parameters for voltage control

Parameter	Symbol	Value	Unit
Proportional gain	K_p	1	mA^{-1}
Integral gain	K_i	0	$\text{mA}^{-1}\text{ms}^{-1}$
Derivative gain	K_d	0	mA^{-1}ms
Integral term limit	M_I	N.A.	N.A.
PID output limit	M_{PID}	1,500	N.A.
Scaling factor	S_v	-0.5	mV

2.2.5 Power Transmitter design A5

Power Transmitter design A5 has been deprecated. For further information, see the note in Section 2.1.

2.2.6 Power Transmitter design A6

Figure 15 illustrates the functional block diagram of this design, which consists of two major functional units, namely a Power Conversion Unit and a Communications and Control Unit.

Figure 15. Functional block diagram of Power Transmitter design A6

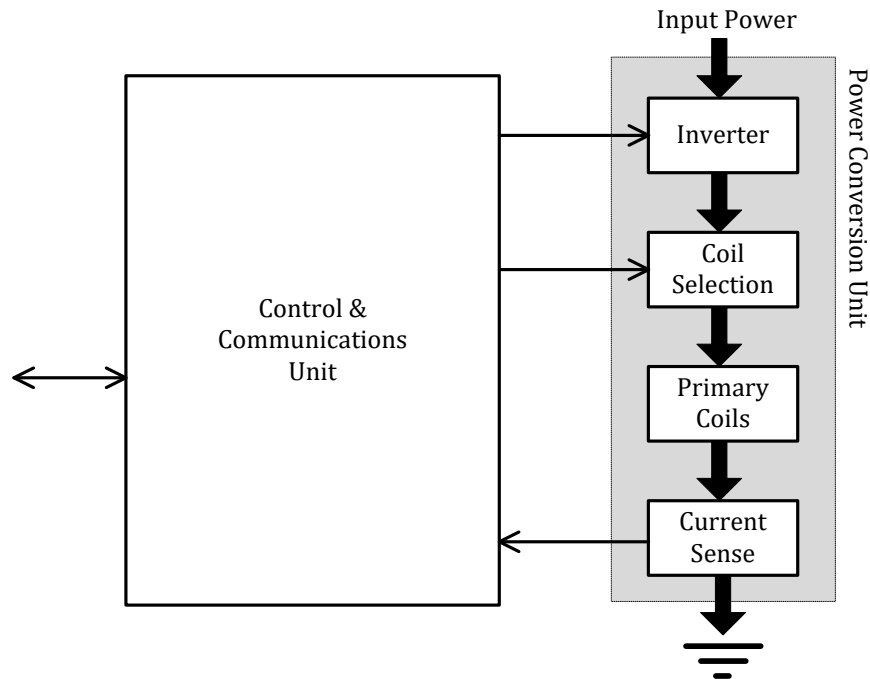

The Power Conversion Unit on the right-hand side of Figure 15 comprises the analog parts of the design. The inverter converts the DC input to an AC waveform that drives a resonant circuit, which consists of the selected Primary Coil plus a series capacitor. The selected Primary Coil is one from a linear array of partially overlapping Primary Coils, as appropriate for the position of the Power Receiver relative to the Primary Coils. Selection of the Primary Coil proceeds by the Power Transmitter attempting to establish communication with a Power Receiver using any of the Primary Coils. Note that the array may consist of a single Primary Coil only, in which case the selection is trivial. Finally, the current sense monitors the Primary Coil current.

The Communications and Control Unit on the left-hand side of Figure 15 comprises the digital logic part of the design. This unit receives and decodes messages from the Power Receiver, configures the Coil Selection block to connect the appropriate Primary Coil, executes the relevant power control algorithms and protocols, and drives the frequency of the AC waveform to control the power transfer. The Communications and Control Unit also interfaces with other subsystems of the Base Station, e.g. for user interface purposes.

2.2.6.1 Mechanical details

Power Transmitter design A6 includes one or more Primary Coils as defined in Section 2.2.6.1.1, Shielding as defined in Section 2.2.6.1.2, an Interface Surface as defined in Section 2.2.6.1.3.

2.2.6.1.1 Primary Coil

The Primary Coil is of the wire-wound type, and consists of no. 17 AWG (1.15 mm diameter) type 2 litz wire having 105 strands of no. 40 AWG (0.08 mm diameter), or equivalent. As shown in Figure 16, the Primary Coil has a rectangular shape and consists of a single layer. Table 8 lists the dimensions of the Primary Coil.

Figure 16. Primary Coil of Power Transmitter design A6

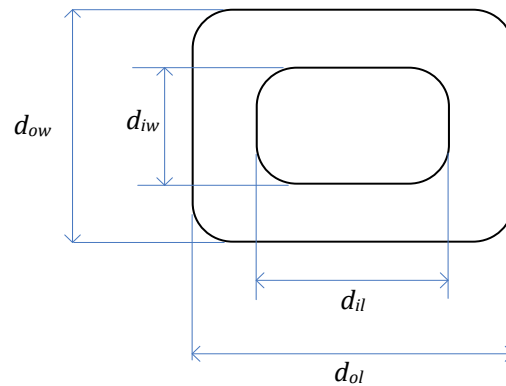
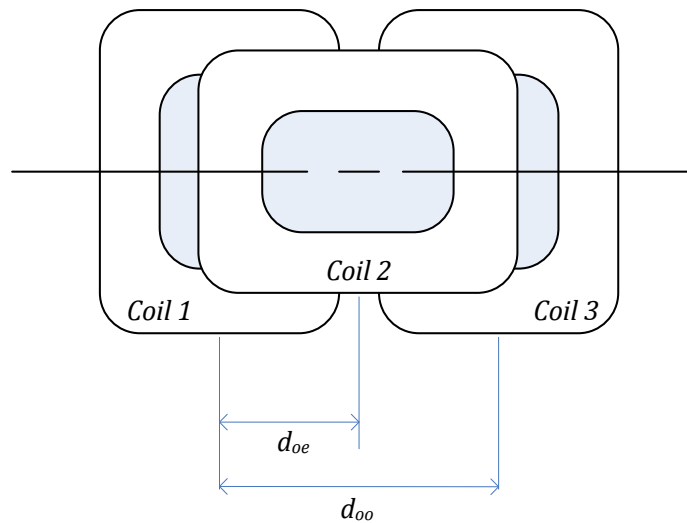

Table 8. Primary Coil parameters of Power Transmitter design A6

Parameter	Symbol	Value
Outer length	d_{ol}	$53.2^{\pm 0.5}$ mm
Inner length	d_{il}	$27.5^{\pm 0.5}$ mm
Outer width	d_{ow}	$45.2^{\pm 0.5}$ mm
Inner width	d_{iow}	$19.5^{\pm 0.5}$ mm
Thickness	d_c	$1.5^{\pm 0.5}$ mm
Number of turns per layer	N	12 turns
Number of layers	-	1

Power Transmitter design A6 contains at least one Primary Coil. Odd numbered coils are placed alongside each other with a displacement of $d_{oo} = 49.2^{\pm 4}$ mm between their centers. Even numbered coils are placed orthogonal to the odd numbered coils with a displacement of $d_{oe} = 24.6^{\pm 2}$ mm between their centers. See Figure 17.

Figure 17. Primary Coils of Power Transmitter design A6



2.2.6.1.2 Shielding

As shown in Figure 18, Shielding protects the Base Station from the magnetic field that is generated in the Primary Coil. The Shielding should be Ni-Zn or Mn-Zn ferrite and should be at least 0.5 mm thick. The Shielding extends to at least the outer dimensions of the Primary Coils, and is placed below the Primary Coil at a distance of at most $d_s = 1.0$ mm.

Figure 18. Primary Coil assembly of Power Transmitter design A6

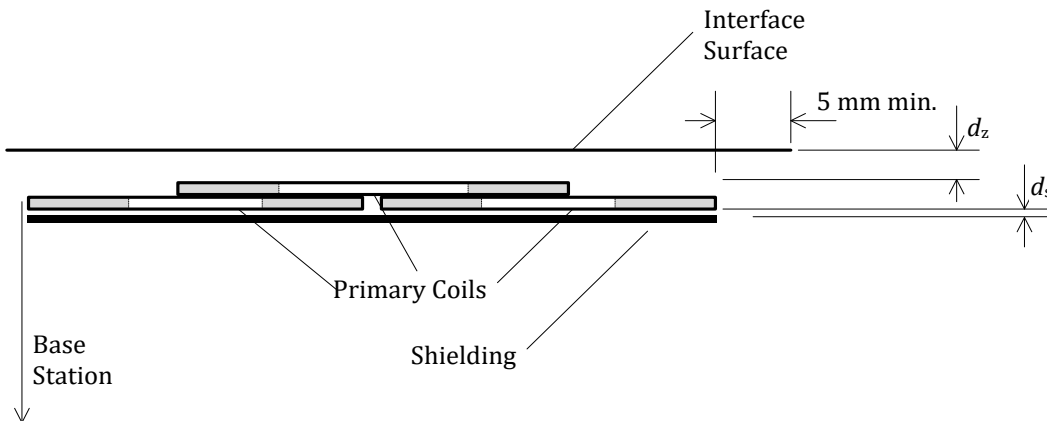

2.2.6.1.3 Interface Surface

As shown in Figure 18, the distance from the Primary Coil to the Interface Surface of the Base Station is $d_z = 2^{+0.5}_{-0.25}$ mm, across the top face of the Primary Coil. In the case of a single Primary Coil, the distance from the Primary Coil to the Interface Surface of the Base Station is $d_z = 3^{+0.5}_{-0.25}$ mm, across the top face of the Primary Coil. In addition, the Interface Surface of the Base Station extends at least 5 mm beyond the outer dimensions of the Primary Coils.

2.2.6.1.4 Inter coil separation

If the Base Station contains multiple type A6 Power Transmitters, the Primary Coils of any pair of those Power Transmitters shall have a center-to-center distance of at least $49.2^{\pm 4}$ mm.

2.2.6.2 Electrical details

As shown in Figure 19, Power Transmitter design A6 uses a half-bridge inverter to drive an individual Primary Coil and a series capacitance. Within the Operating Frequency range specified below, the assembly of Primary Coils and Shielding has a self inductance $L_p = 11.5^{\pm 10\%}$ μ H for coils closest to the Interface Surface and inductance $L_p = 12.5^{\pm 10\%}$ μ H for coils furthest from the Interface Surface. The value of the series capacitance is $C_p = 0.147^{\pm 5\%}$ μ F for coils closest to the Interface Surface and $C_p = 0.136^{\pm 5\%}$ μ F for coils furthest from the Interface Surface. The input voltage to the half-bridge inverter is $12^{\pm 5\%}$ V.

NOTE Near resonance, the voltage developed across the series capacitance can reach levels exceeding 100 V pk-pk.

Power Transmitter design A6 uses the Operating Frequency and duty cycle of the Power Signal in order to control the amount of power that is transferred. For this purpose, the Operating Frequency range of the half-bridge inverter is $f_{op} = 115 \dots 205$ kHz with a duty cycle of 50%; and its duty cycle range is 10...50% at an Operating Frequency of 205 kHz. A higher Operating Frequency or lower duty cycle result in the transfer of a lower amount of power. In order to achieve a sufficiently accurate adjustment of the amount of power that is transferred, a type A6 Power Transmitter shall control the Operating Frequency with a resolution of

- $0.01 \times f_{op} - 0.7$ kHz, for f_{op} in the 115...175 kHz range;
- $0.015 \times f_{op} - 1.58$ kHz, for f_{op} in the 175...205 kHz range;

or better. In addition, a type A6 Power Transmitter shall control the duty cycle of the Power Signal with a resolution of 0.1% or better.

When a type A6 Power Transmitter first applies a Power Signal (Digital Ping; see *Parts 1 and 2: Interface Definitions*), it shall use an initial Operating Frequency of 175 kHz (and a duty cycle of 50%).

Control of the power transfer shall proceed using the PID algorithm, which is defined in *Parts 1 and 2: Interface Definitions*. The controlled variable $v^{(i)}$ introduced in the definition of that algorithm represents the Operating Frequency or the duty cycle. In order to guarantee sufficiently accurate power control, a type A6 Power Transmitter shall determine the amplitude of the Primary Cell current—which is equal to the Primary Coil current—with a resolution of 7 mA or better. Finally, Table 9, Table 10, and Table 11 provide the values of several parameters, which are used in the PID algorithm.

Figure 19. Electrical diagram (outline) of Power Transmitter design A6

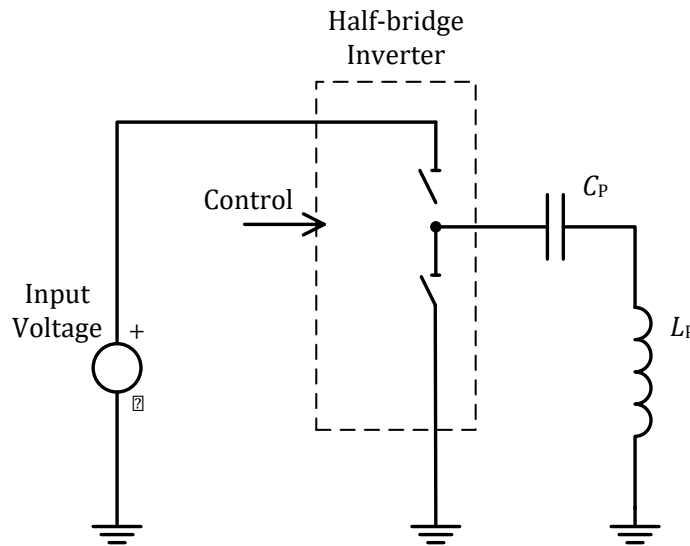

Table 9. PID parameters for Operating Frequency control

Parameter	Symbol	Value	Unit
Proportional gain	K_p	10	mA^{-1}
Integral gain	K_i	0.05	$\text{mA}^{-1}\text{ms}^{-1}$
Derivative gain	K_d	0	mA^{-1}ms
Integral term limit	M_I	3,000	N.A.
PID output limit	M_{PID}	20,000	N.A.

Table 10. Operating Frequency dependent scaling factor

Frequency Range [kHz]	Scaling Factor S_v [Hz]
115...140	1.5
140...160	2
160...180	3
180...205	5

Table 11. PID parameters for duty cycle control

Parameter	Symbol	Value	Unit
Proportional gain	K_p	10	mA^{-1}
Integral gain	K_i	0.05	$\text{mA}^{-1}\text{ms}^{-1}$
Derivative gain	K_d	0	mA^{-1}ms
Integral term limit	M_i	3,000	N.A.
PID output limit	M_{PID}	20,000	N.A.
Scaling factor	S_v	-0.01	%

2.2.7 Power Transmitter design A7

Power Transmitter design A7 enables Free Positioning, and has a design similar to Power Transmitter design A2. See Section 0 for an overview.

2.2.7.1 Mechanical details

Power Transmitter design A7 includes a single Primary Coil as defined in Section 2.2.7.1.1, Shielding as defined in Section 2.2.7.1.2, an Interface Surface as defined in Section 2.2.7.1.3, and a positioning stage as defined in Section 2.2.7.1.4.

2.2.7.1.1 Primary Coil

The Primary Coil is of the wire-wound type, and consists of litz wire having 100 strands of 0.08 mm diameter, or equivalent. As shown in Figure 20, the Primary Coil has a circular shape and consists of a single layer. Table 12 lists the dimensions of the Primary Coil.

Figure 20. Primary Coil of Power Transmitter design A7

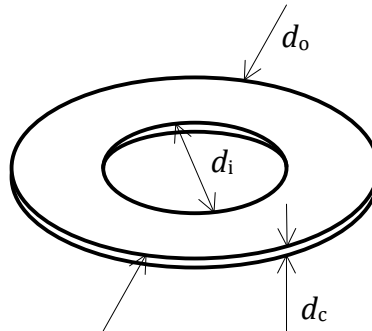

Table 12. Primary Coil parameters of Power Transmitter design A7

Parameter	Symbol	Value
Outer diameter	d_o	$39^{\pm 2}$ mm
Inner diameter	d_i	$12^{\pm 0.2}$ mm
Thickness	d_c	$1.9^{\pm 0.2}$ mm
Number of turns per layer	N	20
Number of layers	–	1

2.2.7.1.2 Shielding

As shown in Figure 21, Shielding protects the Base Station from the magnetic field that is generated in the Primary Coil. The Shielding should be Ni-Zn or Mn-Zn ferrite and should be at least 0.6 mm thick. The Shielding extends to at least the edges of the Primary Coil, and is placed below the Primary Coil at a distance of at most $d_s = 0.5\text{mm}$.

Figure 21. Primary Coil assembly of Power Transmitter design A7

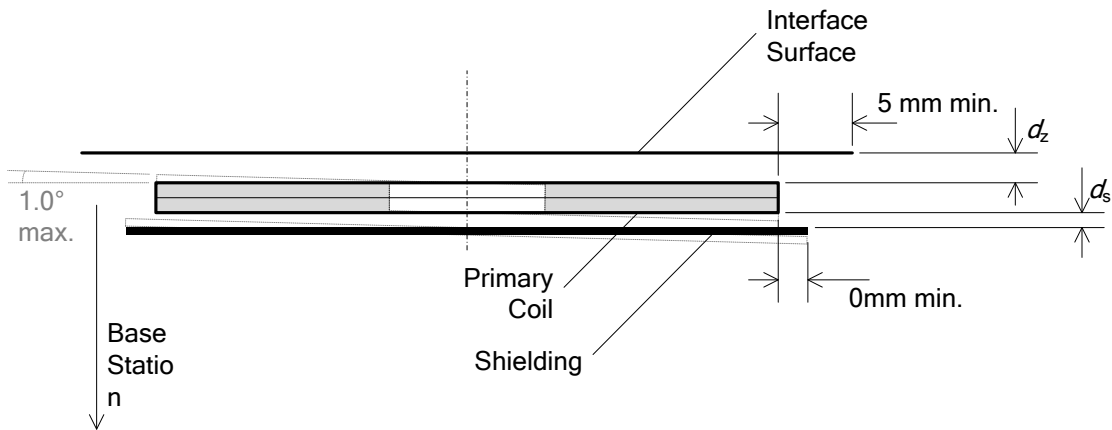

2.2.7.1.3 Interface Surface

As shown in Figure 21, the distance from the Primary Coil to the Interface Surface of the Base Station is $d_z = 3.0^{\pm 0.5}$ mm, across the top face of the Primary Coil. In addition, the Interface Surface of the Base Station extends at least 5mm beyond the outer diameter of the Primary Coil.

2.2.7.1.4 Positioning stage

The positioning stage shall have a resolution of 0.1mm or better in each of the two orthogonal directions parallel to the Interface Surface.

2.2.7.2 Electrical details

As shown in Figure 22, Power Transmitter design A7 uses a full-bridge inverter to drive the Primary Coil and a series capacitance. At an Operating Frequency range between 105 kHz and 140 kHz, the assembly of Primary Coil and Shielding has a self inductance $L_p = 13.6^{\pm 10\%}$ μH . The value of the series capacitance is $C_p = 180^{\pm 5\%}$ nF.

NOTE Near resonance, the voltage developed across the series capacitance can reach levels up to 100 V pk-pk.

Power Transmitter design A7 uses the input voltage to the full-bridge inverter to control the amount of power that is transferred. For this purpose, the input voltage range is 3...12 V, where a lower input voltage results in the transfer of a lower amount of power. In order to achieve a sufficiently accurate adjustment of the power that is transferred, a type A7 Power Transmitter shall be able to control the input voltage with a resolution of 50 mV or better.

When a type A7 Power Transmitter first applies a Power Signal (Digital Ping; see *Parts 1 and 2: Interface Definitions*), it shall use an initial input voltage of 6.5 V. It is recommended that the Power Transmitter uses an Operating Frequency of 140 kHz when first applying the Power Signal. If the Power Transmitter does not receive a Signal Strength Packet from the Power Receiver, the Power Transmitter shall remove the Power Signal as defined in *Parts 1 and 2: Interface Definitions*. The Power Transmitter may reapply the Power Signal multiple times at other—consecutively lower—Operating Frequencies within the range specified above, until the Power Transmitter receives a Signal Strength Packet containing an appropriate Signal Strength Value.

Figure 22. Electrical diagram (outline) of Power Transmitter design A7

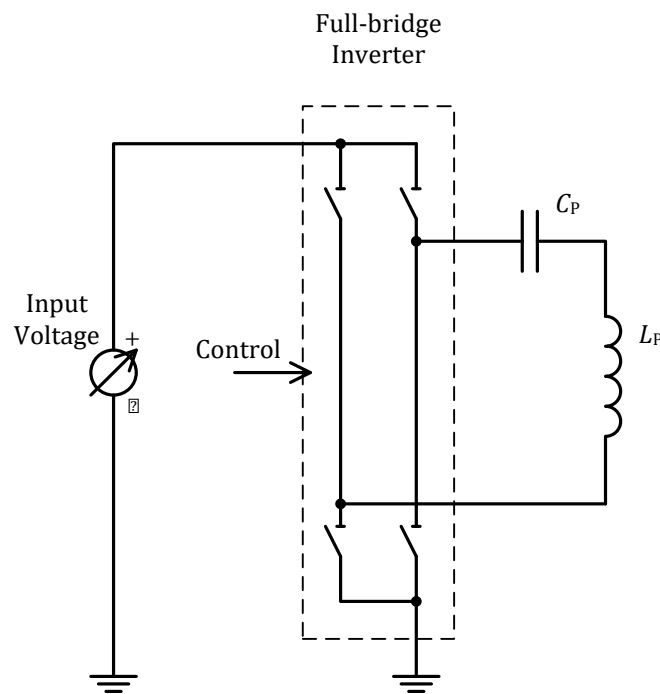

Control of the power transfer shall proceed using the PID algorithm, which is defined in *Parts 1 and 2: Interface Definitions*. The controlled variable $v^{(i)}$ introduced in the definition of that algorithm represents the input voltage to the full-bridge inverter. In order to guarantee sufficiently accurate power control, a type A7 Power Transmitter shall determine the amplitude of the Primary Cell voltage—which is equal to the Primary Coil voltage—with a resolution of 5 mV or better. Finally, Table 13 provides the values of several parameters, which are used in the PID algorithm.

Table 13. PID parameters for voltage control

Parameter	Symbol	Value	Unit
Proportional gain	K_p	1	mA ⁻¹
Integral gain	K_i	0	mA ⁻¹ ms ⁻¹
Derivative gain	K_d	0	mA ⁻¹ ms
Integral term limit	M_i	N.A.	N.A.
PID output limit	M_{PID}	1,500	N.A.
Scaling factor	S_v	-0.5	mV

2.2.8 Power Transmitter design A8

Power Transmitter design A8 enables Free Positioning. Figure 23 illustrates the functional block diagram of this design, which consists of two major functional units, namely a Power Conversion Unit and a Communications and Control Unit.

Figure 23. Functional block diagram of Power Transmitter design A8

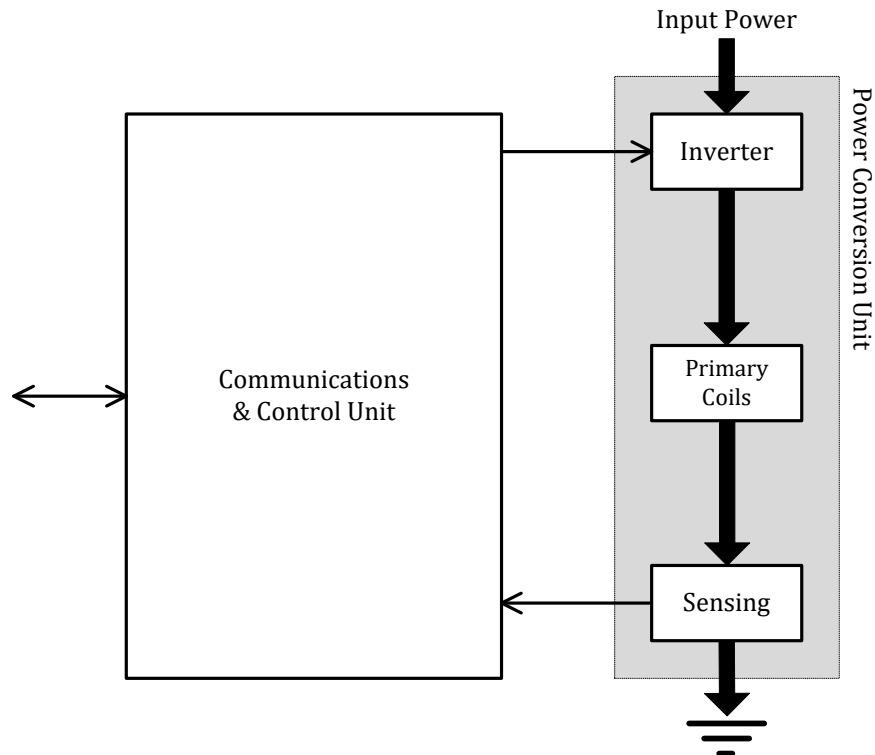

The Power Conversion Unit on the right-hand side of Figure 23 comprises the analog parts of the design. The inverter converts the DC input to an AC waveform that drives a resonant circuit, which consists of the Primary Coil plus a series capacitor. Finally, the voltage and current sense monitors the Primary Coil voltage and current.

The Communications and Control Unit on the left-hand side of Figure 23 comprises the digital logic part of the design. The unit receives and decodes messages from the Power Receiver, executes the relevant power control algorithms and protocols, and drives the input power and frequency of the AC waveform to control the power transfer. The Communications and Control Unit also interfaces with other subsystems of the Base Station, e.g. for user interface purposes.

2.2.8.1 Mechanical details

Power Transmitter design A8 includes one Primary Coil as defined in Section 2.2.8.1.1, Shielding as defined in Section 2.2.8.1.2, and an Interface Surface as defined in Section 2.2.8.1.3.

2.2.8.1.1 Primary Coil

The Primary Coil is of the wire-wound type, and consists of litz wire having 115 strands of 0.08 mm diameter, or equivalent. As shown in Figure 24, a Primary Coil has a racetrack-like shape and consists of a single layer. Table 14 lists the dimensions of a Primary Coil.

Figure 24. Primary Coil of Power Transmitter design A8

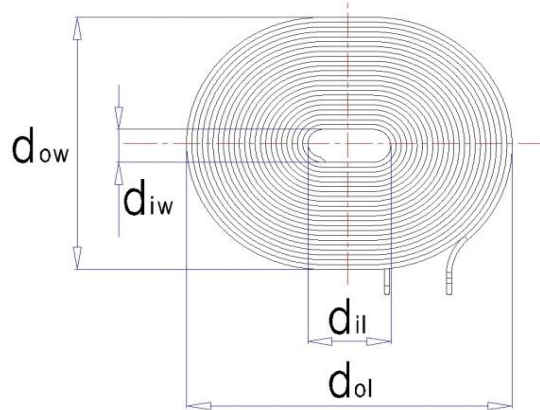

Table 14. Primary Coil parameters of Power Transmitter design A8

Parameter	Symbol	Value
Outer length	d_{ol}	$70^{\pm 0.5}$ mm
Inner length	d_{il}	$15^{\pm 0.5}$ mm
Outer width	d_{ow}	$59^{\pm 0.5}$ mm
Inner width	d_{iw}	$4^{\pm 0.5}$ mm
Thickness	d_c	$1.2^{\pm 0.15}$ mm
Number of turns per layer	N	23.5
Number of layers	-	1

2.2.8.1.2 Shielding

As shown in Figure 25, Shielding protects the Base Station from the magnetic field that is generated in the Primary Coil. The Shielding should be Ni-Zn or Mn-Zn ferrite and should be at least 3.1 mm thick.

The top face of the Shielding block is aligned with the top face of the Primary Coil, such that the Shielding surrounds the Primary Coil on all sides except for the top face. In addition, the Shielding extends to at least 2.5 mm beyond the outer edge of the Primary Coil.

Figure 25. Primary Coil assembly of Power Transmitter design A8

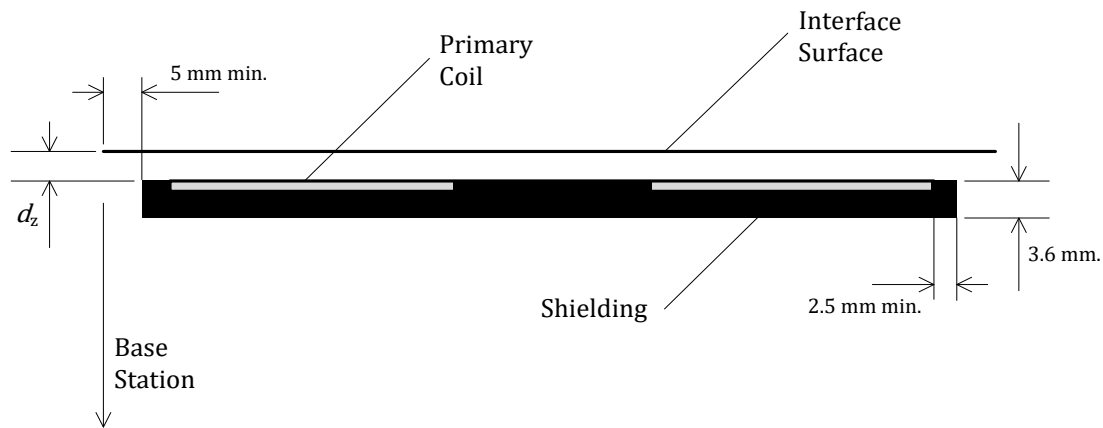

2.2.8.1.3 Interface Surface

As shown in Figure 25, the distance from the Primary Coil to the Interface Surface of the Base Station is $d_z = 2.0^{\pm 0.5}$ mm, across the top face of the Primary Coil. In addition, the Interface Surface of the Base Station extends at least 5 mm beyond the outer diameter of the Primary Coil.

2.2.8.1.4 Separation between multiple Power transmitters

If the Base Station contains multiple type A8 Power Transmitters, the Primary Coils of any pair of those Power Transmitters shall have a center-to-center distance of at least 70 mm.

2.2.8.2 Electrical details

As shown in Figure 26, Power Transmitter design A8 uses a full-bridge inverter to drive the Primary Coil and a series capacitance. Within the Operating Frequency range of 110...180 kHz, the assembly of Primary Coil and Shielding has a self inductance $L_p = 24^{\pm 0.5} \mu\text{H}$. The value of the series capacitance is $C_p = 100^{\pm 5\%} \text{ nF}$. The input voltage to the full-bridge inverter is $5^{\pm 0.5} \dots 11^{\pm 0.5} \text{ V}$.

NOTE Near resonance, the voltage developed across the series capacitance can reach levels up to 100 V pk-pk.

Power Transmitter design A8 uses the Operating Frequency and the input voltage to the full-bridge inverter to control the amount of power that is transferred. In order to achieve a sufficiently accurate adjustment of the power that is transferred, a type A8 Power Transmitter shall be able to control the frequency with a resolution of 0.5 kHz, and the input voltage with a resolution of 50 mV or better.

When a type A8 Power Transmitter first applies a Power Signal (Digital Ping; see *Parts 1 and 2: Interface Definitions*), the Power Transmitter shall use an Operating Frequency of 130 kHz, and an input voltage of 8 V. If the Power Transmitter does not to receive a Signal Strength Packet from the Power Receiver, the Power Transmitter shall remove the Power Signal as defined in *Parts 1 and 2: Interface Definitions*. The Power Transmitter may reapply the Power Signal multiple times at an Operating Frequency of 130 kHz using consecutively higher input voltages within the range specified above, until the Power Transmitter receives a Signal Strength Packet containing an appropriate Signal Strength Value.

Figure 26. Electrical diagram (outline) of Power Transmitter design A8

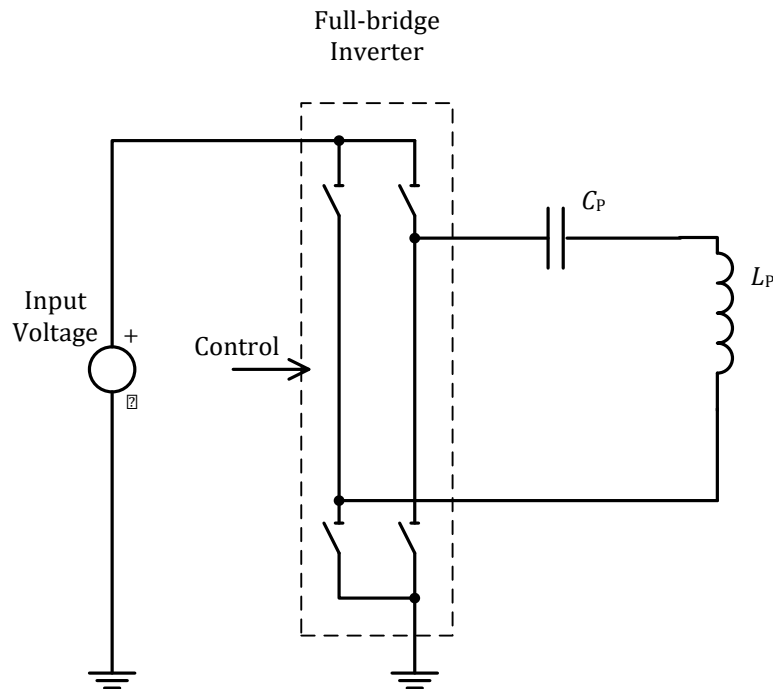

Control of the power transfer shall proceed using the PID algorithm, which is defined in *Parts 1 and 2: Interface Definitions*. The controlled variable $v^{(i)}$ introduced in the definition of that algorithm represents Operating Frequency as well as the input voltage to the full-bridge inverter. It is recommended that control of the power occurs primarily by means of adjustments to the Operating Frequency, and that voltage adjustments are made only at the boundaries of the Operating Frequency range. In order to guarantee sufficiently accurate power control, a type A8 Power Transmitter shall determine the amplitude of the Primary Coil current with a resolution of 5 mA or better. Finally, Table 15 and Table 16 provide the values of several parameters, which are used in the PID algorithm.

Table 15. PID parameters for Operating Frequency control

Parameter	Symbol	Value	Unit
Proportional gain	K_p	1	mA^{-1}
Integral gain	K_i	0	$\text{mA}^{-1}\text{ms}^{-1}$
Derivative gain	K_d	0	mA^{-1}ms
Integral term limit	M_I	N.A.	N.A.
PID output limit	M_{PID}	20,000	N.A.
Scaling factor	S_v	1.0	Hz

Table 16. PID parameters for voltage control

Parameter	Symbol	Value	Unit
Proportional gain	K_p	1	mA^{-1}
Integral gain	K_i	0	$\text{mA}^{-1}\text{ms}^{-1}$
Derivative gain	K_d	0	mA^{-1}ms
Integral term limit	M_I	N.A.	N.A.
PID output limit	M_{PID}	1,500	N.A.
Scaling factor	S_v	-0.5	mV

2.2.9 Power Transmitter design A9

Power Transmitter design A9 has been deprecated. For further information, see the note in Section 2.1.

2.2.10 Power Transmitter design A10

Power Transmitter design A10 enables Guided Positioning. Figure 27 illustrates the functional block diagram of this design, which consists of two major functional units, namely a Power Conversion Unit and a Communications and Control Unit.

Figure 27. Functional block diagram of Power Transmitter design A10

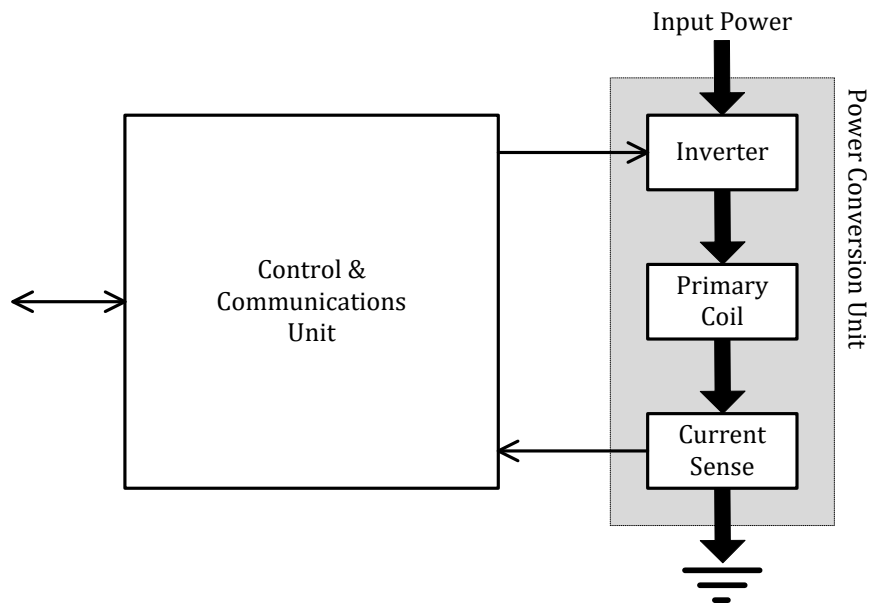

The Power Conversion Unit on the right-hand side of Figure 27 comprises the analog parts of the design. The inverter converts the DC input to an AC waveform that drives a resonant circuit, which consists of the Primary Coil plus a series capacitor. Finally, the current sense monitors the Primary Coil current.

The Communications and Control Unit on the left-hand side of Figure 27 comprises the digital logic part of the design. This unit receives and decodes messages from the Power Receiver, executes the relevant power control algorithms and protocols, and drives the frequency of the AC waveform to control the power transfer. The Communications and Control Unit also interfaces with other subsystems of the Base Station, e.g. for user interface purposes.

2.2.10.1 Mechanical details

Power Transmitter design A10 includes a single Primary Coil as defined in Section 2.2.10.1.1, Shielding as defined in Section 2.2.10.1.2, an Interface Surface as defined in Section 2.2.10.1.3, and an alignment aid as defined in Section 2.2.10.1.4.

2.2.10.1.1 Primary Coil

The Primary Coil is of the wire-wound type, and consists of no. 17 AWG (1.15 mm diameter) type 2 litz wire having 105 strands of no. 40 AWG (0.08 mm diameter), or equivalent. As shown in Figure 28, the Primary Coil has a circular shape and consists of multiple layers. All layers are stacked with the same polarity. Table 17 lists the dimensions of the Primary Coil.

Figure 28. Primary Coil of Power Transmitter design A10

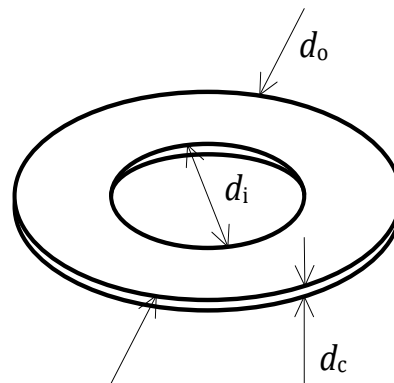

Table 17. Primary Coil parameters of Power Transmitter design A10

Parameter	Symbol	Value
Outer diameter	d_o	$43^{\pm 0.5}$ mm
Inner diameter	d_i	$20.5^{\pm 0.5}$ mm
Thickness	d_c	$2.1^{+0.5}$ mm
Number of turns per layer	N	10
Number of layers	-	2

2.2.10.1.2 Shielding

As shown in Figure 29, Shielding protects the Base Station from the magnetic field that is generated in the Primary Coil. The Shielding should be Ni-Zn or Mn-Zn ferrite and should be at least 0.5 mm thick. The Shielding extends to at least 2 mm beyond the outer diameter of the Primary Coil, and is placed below the Primary Coil at a distance of at most $d_s = 1.0$ mm.

Figure 29. Primary Coil assembly of Power Transmitter design A10

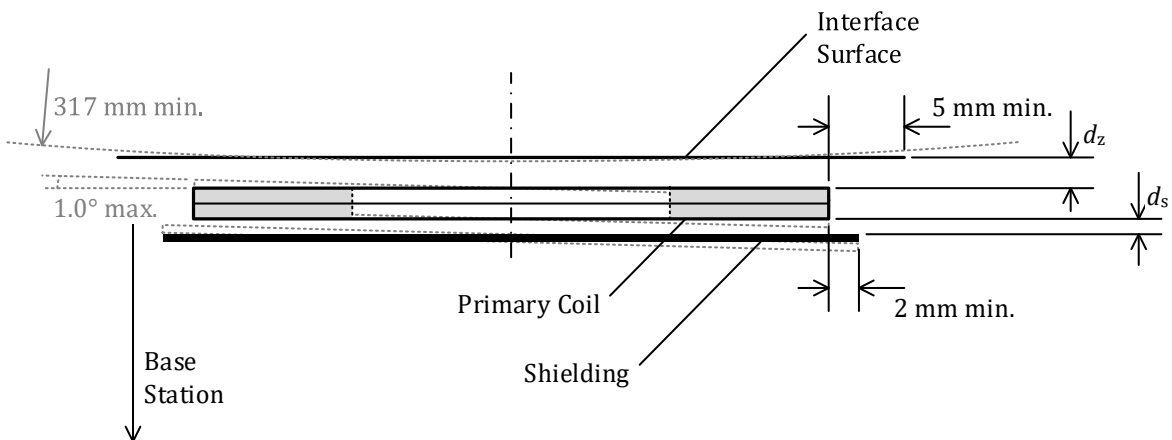

2.2.10.1.3 Interface Surface

As shown in Figure 29 the distance from the Primary Coil to the Interface Surface of the Base Station is $d_z = 2^{+0.5}_{-0.25}$ mm, across the top face of the Primary Coil. In addition, the Interface Surface of the Base Station extends at least 5 mm beyond the outer diameter of the Primary Coil.

NOTE This Primary-Coil-to-Interface-Surface distance implies that the tilt angle between the Primary Coil and a flat Interface Surface is at most 1.0° . Alternatively, in case of a non-flat Interface Surface, this Primary-Coil-to-Interface-Surface distance implies a radius of curvature of the Interface Surface of at least 317 mm, centered on the Primary Coil. See Figure 29.

2.2.10.1.4 Alignment aid

The user manual of the Base Station containing a type A10 Power Transmitter shall have information about the location of its Active Area(s).

For the best user experience, it is recommended to employ at least one user feedback mechanism during Mobile Device positioning to help alignment.

NOTE Examples of Base Station alignment aids to assist the user positioning of the Mobile Device include:

- A marked Interface Surface to indicate the location of the Active Area(s)—e.g. by means of the logo or other visual marking, lighting, etc.
- A visual feedback display—e.g. by means of illuminating an LED to indicate proper alignment.
- An audible or haptic feedback mechanism.

2.2.10.1.5 Inter coil separation

If the Base Station contains multiple type A10 Power Transmitters, the Primary Coils of any pair of those Power Transmitters shall have a center-to-center distance of at least 50 mm.

2.2.10.2 Electrical details

As shown in Figure 30, Power Transmitter design A10 uses a half-bridge inverter to drive the Primary Coil and a series capacitance. Within the Operating Frequency range specified below, the assembly of Primary Coil, Shielding, and magnet has a self inductance $L_p = 24^{\pm 10\%}$ μH . The value of the series capacitance is $C_p = 100^{\pm 5\%}$ nF. The input voltage to the half-bridge inverter is $19^{\pm 1}$ V.

NOTE Near resonance, the voltage developed across the series capacitance can reach levels exceeding 200 V pk-pk.

Power Transmitter design A10 uses the Operating Frequency and duty cycle of the Power Signal in order to control the amount of power that is transferred. For this purpose, the Operating Frequency range of the half-bridge inverter is $f_{op} = 110 \dots 205$ kHz with a duty cycle of 50%; and its duty cycle range is 10...50% at an Operating Frequency of 205 kHz. A higher Operating Frequency or lower duty cycle result in the transfer of a lower amount of power. In order to achieve a sufficiently accurate adjustment of the amount of power that is transferred, a type A10 Power Transmitter shall control the Operating Frequency with a resolution of

- $0.01 \times f_{op} - 0.7$ kHz, for f_{op} in the 110...175 kHz range;
- $0.015 \times f_{op} - 1.58$ kHz, for f_{op} in the 175...205 kHz range;

or better. In addition, a type A10 Power Transmitter shall control the duty cycle of the Power Signal with a resolution of 0.1% or better.

When a type A10 Power Transmitter first applies a Power Signal (Digital Ping; see *Parts 1 and 2: Interface Definitions*), it shall use an initial Operating Frequency of 175 kHz (and a duty cycle of 50%).

Control of the power transfer shall proceed using the PID algorithm, which is defined in *Parts 1 and 2: Interface Definitions*. The controlled variable $v^{(i)}$ introduced in the definition of that algorithm represents the Operating Frequency or the duty cycle. In order to guarantee sufficiently accurate power control, a type A10 Power Transmitter shall determine the amplitude of the Primary Cell current—which is equal to the Primary Coil current—with a resolution of 7 mA or better. Finally, Table 18, Table 19, and Table 20 provide the values of several parameters, which are used in the PID algorithm.

Figure 30. Electrical diagram (outline) of Power Transmitter design A10

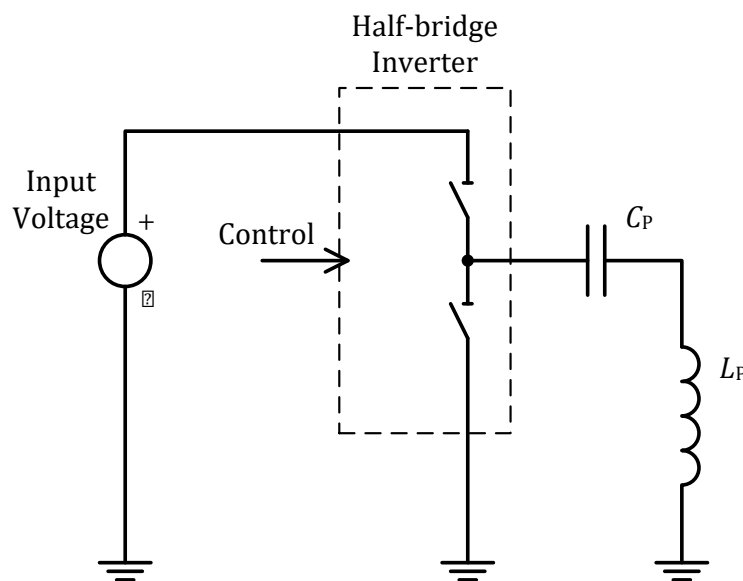

Table 18. PID parameters for Operating Frequency control

Parameter	Symbol	Value	Unit
Proportional gain	K_p	10	mA^{-1}
Integral gain	K_i	0.05	$\text{mA}^{-1}\text{ms}^{-1}$
Derivative gain	K_d	0	mA^{-1}ms
Integral term limit	M_i	3,000	N.A.
PID output limit	M_{PID}	20,000	N.A.

Table 19. Operating Frequency dependent scaling factor

Frequency Range [kHz]	Scaling Factor S_v [Hz]
110...140	1.5
140...160	2
160...180	3
180...205	5

Table 20. PID parameters for duty cycle control

Parameter	Symbol	Value	Unit
Proportional gain	K_p	10	mA ⁻¹
Integral gain	K_i	0.05	mA ⁻¹ ms ⁻¹
Derivative gain	K_d	0	mA ⁻¹ ms
Integral term limit	M_i	3,000	N.A.
PID output limit	M_{PID}	20,000	N.A.
Scaling factor	S_v	-0.01	%

2.2.11 Power Transmitter design A11

Power Transmitter design A11 enables Guided Positioning. Figure 31 illustrates the functional block diagram of this design, which consists of two major functional units, namely a Power Conversion Unit and a Communications and Control Unit.

Figure 31. Functional block diagram of Power Transmitter design A11

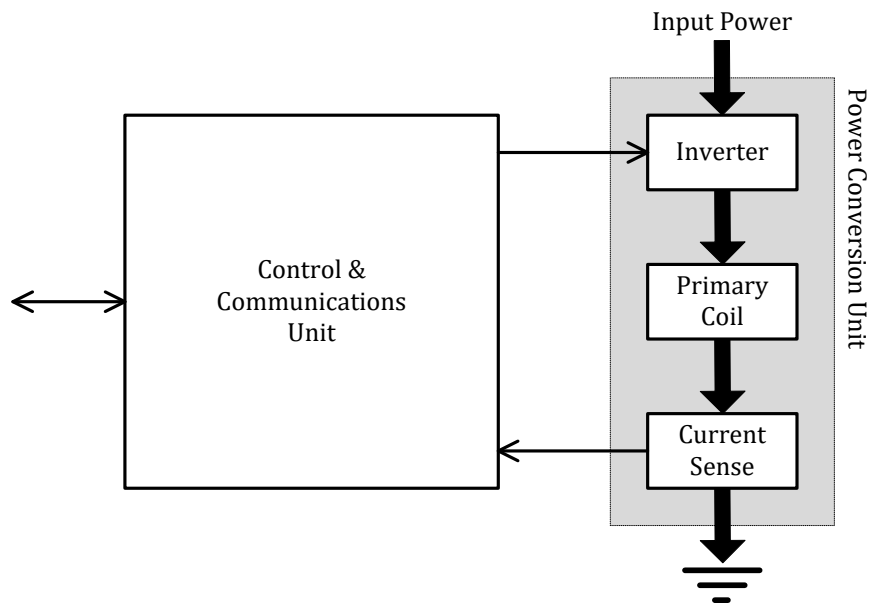

The Power Conversion Unit on the right-hand side of Figure 31 comprises the analog parts of the design. The inverter converts the DC input to an AC waveform that drives a resonant circuit, which consists of the Primary Coil plus a series capacitor. Finally, the current sense monitors the Primary Coil current.

The Communications and Control Unit on the left-hand side of Figure 31 comprises the digital logic part of the design. This unit receives and decodes messages from the Power Receiver, executes the relevant power control algorithms and protocols, and drives the frequency of the AC waveform to control the power transfer. The Communications and Control Unit also interfaces with other subsystems of the Base Station, e.g. for user interface purposes.

2.2.11.1 Mechanical details

Power Transmitter design A11 includes a single Primary Coil as defined in Section 2.2.11.1.1, Shielding as defined in Section 2.2.11.1.2, an Interface Surface as defined in Section 2.2.11.1.3, and an alignment aid as defined in Section 2.2.11.1.4.

2.2.11.1.1 Primary Coil

The Primary Coil is of the wire-wound type, and consists of no. 17 AWG (1.15 mm diameter) type 2 litz wire having 105 strands of no. 40 AWG (0.08 mm diameter), or equivalent. As shown in Figure 32, the Primary Coil has a circular shape and consists of one or two layers. Table 21 lists the dimensions of the Primary Coil.

Figure 32. Primary Coil of Power Transmitter design A11

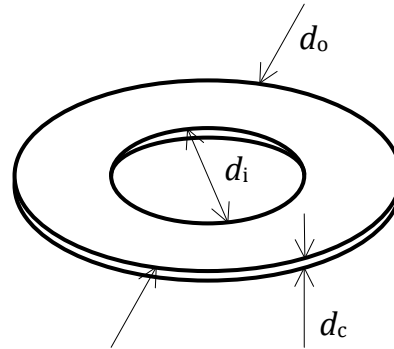

Table 21. Primary Coil parameters of Power Transmitter design A11

Parameter	Symbol	Value
Outer diameter	d_o	$44^{\pm 1.5}$ mm
Inner diameter	d_i	$20.5^{\pm 0.5}$ mm
Thickness	d_c	$2.1^{+0.5}$ mm
Number of turns per layer	N	10 (5 bifilar turns)
Number of layers	-	1 or 2

2.2.11.1.2 Shielding

As shown in Figure 33, Shielding protects the Base Station from the magnetic field that is generated in the Primary Coil. The Shielding should be Ni-Zn or Mn-Zn ferrite and should be at least 0.5 mm thick. The Shielding extends to at least 2 mm beyond the outer diameter of the Primary Coil, and is placed below the Primary Coil at a distance of at most $d_s = 1.0$ mm.

Figure 33. Primary Coil assembly of Power Transmitter design A11

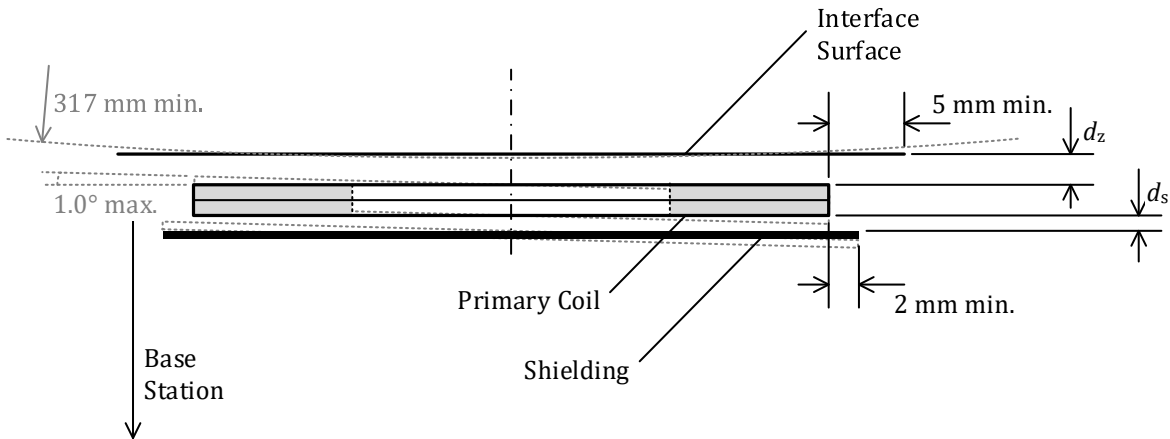

2.2.11.1.3 Interface Surface

As shown in Figure 33 the distance from the Primary Coil to the Interface Surface of the Base Station is $d_z = 2^{+0.5}_{-0.25}$ mm, across the top face of the Primary Coil. In addition, the Interface Surface of the Base Station extends at least 5 mm beyond the outer diameter of the Primary Coil.

NOTE This Primary-Coil-to-Interface-Surface distance implies that the tilt angle between the Primary Coil and a flat Interface Surface is at most 1.0°. Alternatively, in case of a non-flat Interface Surface, this Primary-Coil-to-Interface-Surface distance implies a radius of curvature of the Interface Surface of at least 317 mm, centered on the Primary Coil. See Figure 33.

2.2.11.1.4 Alignment aid

The user manual of the Base Station containing a type A11 Power Transmitter shall have information about the location of its Active Area(s).

For the best user experience, it is recommended to employ at least one user feedback mechanism during Mobile Device positioning to help alignment.

NOTE Examples of Base Station alignment aids to assist the user positioning of the Mobile Device include:

- A marked Interface Surface to indicate the location of the Active Area(s)—e.g. by means of the logo or other visual marking, lighting, etc.
- A visual feedback display—e.g. by means of illuminating an LED to indicate proper alignment.
- An audible or haptic feedback mechanism.

2.2.11.1.5 Inter coil separation

If the Base Station contains multiple type A11 Power Transmitters, the Primary Coils of any pair of those Power Transmitters shall have a center-to-center distance of at least 50 mm.

2.2.11.2 Electrical details

As shown in Figure 34, Power Transmitter design A11 uses a full-bridge inverter to drive the Primary Coil and a series capacitance. Within the Operating Frequency range specified below, the assembly of Primary Coil and Shielding has a self inductance $L_p = 6.3^{\pm 10\%}$ μ H. The value of the series capacitance is $C_p = 0.4^{\pm 5\%}$ μ F. The input voltage to the full-bridge inverter is $5^{\pm 5\%}$ V.

NOTE Near resonance, the voltage developed across the series capacitance can reach levels exceeding 100 V pk-pk.

Power Transmitter design A11 uses the Operating Frequency and duty cycle of the Power Signal in order to control the amount of power that is transferred. For this purpose, the Operating Frequency range of the full-bridge inverter is $f_{op} = 110 \dots 205$ kHz with a duty cycle of 50%; and its duty cycle range is 10...50% at an Operating Frequency of 205 kHz. A higher Operating Frequency or lower duty cycle result in the transfer of a lower amount of power. In order to achieve a sufficiently accurate adjustment of the amount of power that is transferred, a type A11 Power Transmitter shall control the Operating Frequency with a resolution of

- $0.01 \times f_{op} - 0.7$ kHz, for f_{op} in the 110...175 kHz range;
- $0.015 \times f_{op} - 1.58$ kHz, for f_{op} in the 175...205 kHz range;

or better. In addition, a type A11 Power Transmitter shall control the duty cycle of the Power Signal with a resolution of 0.1% or better.

When a type A11 Power Transmitter first applies a Power Signal (Digital Ping; see *Parts 1 and 2: Interface Definitions*), it shall use an initial Operating Frequency of 175 kHz (and a duty cycle of 50%).

Control of the power transfer shall proceed using the PID algorithm, which is defined in *Parts 1 and 2: Interface Definitions*. The controlled variable $v^{(i)}$ introduced in the definition of that algorithm represents the Operating Frequency or the duty cycle. In order to guarantee sufficiently accurate power control, a type A11 Power Transmitter shall determine the amplitude of the Primary Cell current—which is equal to the Primary Coil current—with a resolution of 7 mA or better. Finally, Table 22, Table 23, and Table 24 provide the values of several parameters, which are used in the PID algorithm.

Figure 34. Electrical diagram (outline) of Power Transmitter design A11

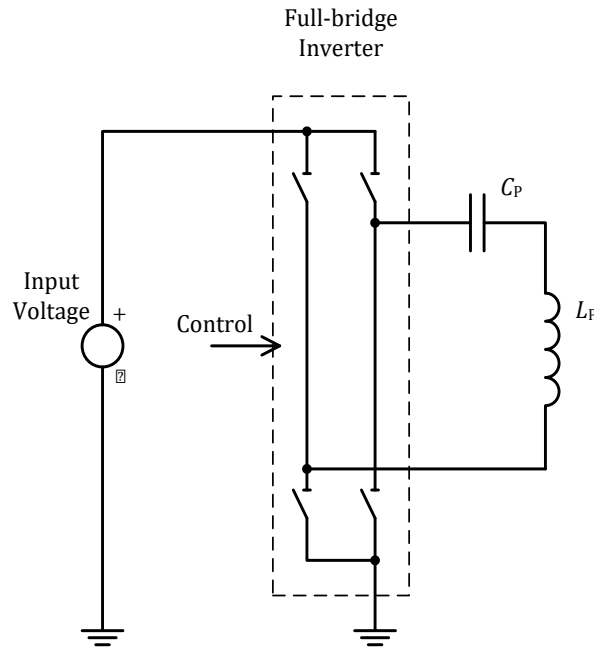

Table 22. PID parameters for Operating Frequency control

Parameter	Symbol	Value	Unit
Proportional gain	K_p	10	mA^{-1}
Integral gain	K_i	0.05	$\text{mA}^{-1}\text{ms}^{-1}$
Derivative gain	K_d	0	mA^{-1}ms
Integral term limit	M_I	3,000	N.A.
PID output limit	M_{PID}	20,000	N.A.

Table 23. Operating Frequency dependent scaling factor

Frequency Range [kHz]	Scaling Factor S_v [Hz]
110...140	1.5
140...160	2
160...180	3
180...205	5

Table 24. PID parameters for duty cycle control

Parameter	Symbol	Value	Unit
Proportional gain	K_p	10	mA^{-1}
Integral gain	K_i	0.05	$\text{mA}^{-1}\text{ms}^{-1}$
Derivative gain	K_d	0	mA^{-1}ms
Integral term limit	M_i	3,000	N.A.
PID output limit	M_{PID}	20,000	N.A.
Scaling factor	S_v	-0.01	%

2.2.12 Power Transmitter design A12

Figure 35 illustrates the functional block diagram of Power Transmitter design A12, which consists of two major functional units, namely a Power Conversion Unit and a Communications and Control Unit.

Figure 35. Functional block diagram of Power Transmitter design A12

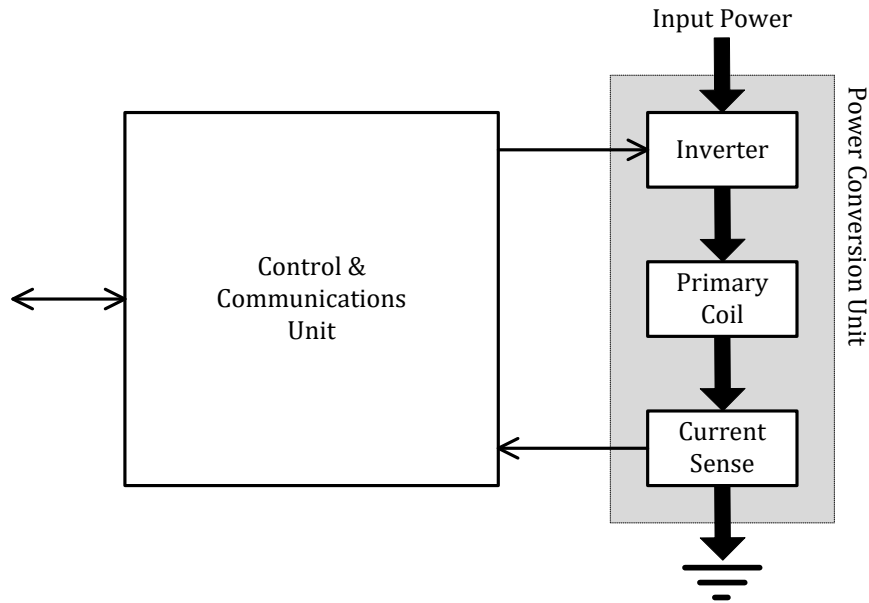

The Power Conversion Unit on the right-hand side of Figure 35 comprises the analog parts of the design. The inverter converts the DC input to an AC waveform that drives a resonant circuit, which consists of the Primary Coil plus a series capacitor. Finally, the current sense monitors the Primary Coil current.

The Communications and Control Unit on the left-hand side of Figure 35 comprises the digital logic part of the design. This unit receives and decodes messages from the Power Receiver, executes the relevant power control algorithms and protocols, and drives the frequency of the AC waveform to control the power transfer. The Communications and Control Unit also interfaces with other subsystems of the Base Station, e.g. for user interface purposes.

2.2.12.1 Mechanical details

Power Transmitter design A12 includes a single Primary Coil as defined in Section 2.2.12.1.1, Shielding as defined in Section 2.2.12.1.2, and an Interface Surface as defined in Section 2.2.12.1.3.

2.2.12.1.1 Primary Coil

The Primary Coil is of the wire-wound type, and consists of litz wire having 115 strands of 0.08 mm diameter, or equivalent. As shown in Figure 36, a Primary Coil has a racetrack-like shape and consists of a single layer. Table 25 lists the dimensions of a Primary Coil.

Figure 36. Primary Coil of Power Transmitter design A12

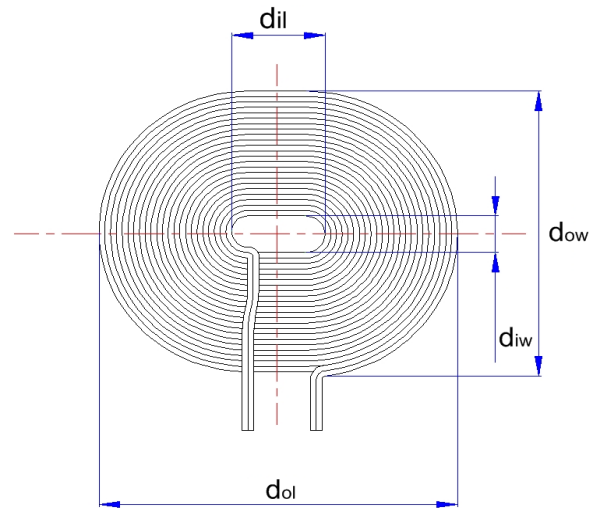

Table 25. Primary Coil parameters of Power Transmitter design A12

Parameter	Symbol	Value
Outer length	d_{oi}	$70^{\pm 0.5}$ mm
Inner length	d_{il}	$15^{\pm 0.5}$ mm
Outer width	d_{ow}	$59^{\pm 0.5}$ mm
Inner width	d_{iw}	$4^{\pm 0.5}$ mm
Thickness	d_c	$1.2^{\pm 0.15}$ mm
Number of turns per layer	N	12 (bifilar turns)
Number of layers	–	1

2.2.12.1.2 Shielding

As shown in Figure 37, Shielding protects the Base Station from the magnetic field that is generated in the Primary Coil. The Shielding should be Ni-Zn or Mn-Zn ferrite and should be at least 0.5 mm thick. The Shielding extends to at least 2.5 mm beyond the outer edge of the Primary Coil.

Figure 37. Primary Coil assembly of Power Transmitter design A12

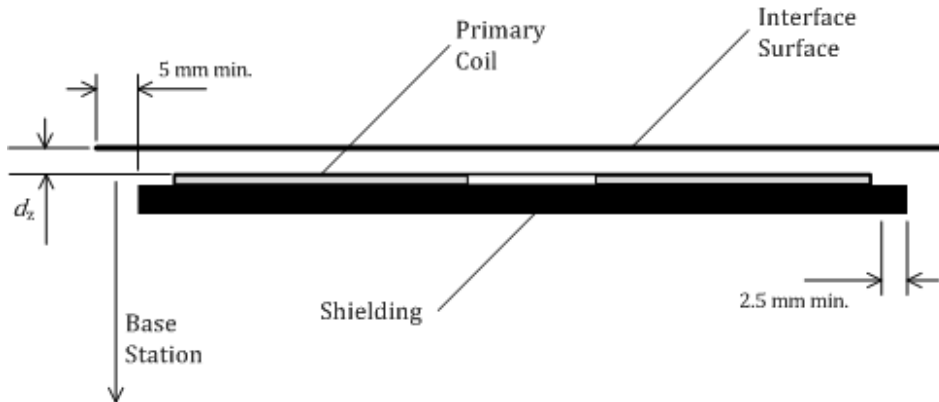

2.2.12.1.3 Interface Surface

As shown in Figure 37, the distance from the Primary Coil to the Interface Surface of the Base Station is $d_z = 2.0^{\pm 0.5}$ mm, across the top face of the Primary Coil. In addition, the Interface Surface of the Base Station extends at least 5 mm beyond the outer diameter of the Primary Coil.

2.2.12.1.4 Inter coil separation

If the Base Station contains multiple type A12 Power Transmitters, the Primary Coils of any pair of those Power Transmitters shall have a center-to-center distance of at least 65 mm.

2.2.12.2 Electrical details

As shown in Figure 38, Power Transmitter design A12 uses a full-bridge inverter to drive the Primary Coil and a series capacitance. Within the Operating Frequency range Specified below, the assembly of Primary Coil and Shielding has a self inductance $L_p = 7^{\pm 10\%}$ μH . The value of the series capacitance is $C_p = 400^{\pm 5\%}$ nF. The input voltage to the full-bridge inverter is $5^{\pm 0.5}$ V.

NOTE Near resonance, the voltage developed across the series capacitance can reach levels up to 100 V pk-pk.

Power Transmitter design A12 uses the Operating Frequency and duty cycle of the full-bridge inverter to control the amount of power that is transferred. For this purpose, the Operating Frequency range of the full-bridge inverter is $f_{op} = 110 \dots 205\text{kHz}$ with a duty cycle of 50% and its duty cycle range is 2 ... 50% at an Operating Frequency of 205 kHz. A higher Operating Frequency and lower duty cycle result in the transfer of a lower amount of power. In order to achieve a sufficiently accurate adjustment of the power that is transferred, a type A12 Power Transmitter shall be able to control the frequency with a resolution of 0.5 kHz or better. a type A12 Power Transmitter shall control the duty cycle of the Power Signal with a resolution of 0.1% or better.

When a type A12 Power Transmitter first applies a Power Signal (Digital Ping; see *Parts 1 and 2: Interface Definitions*), the Power Transmitter shall use an initial Operating Frequency of 175 kHz, and a duty cycle of 50%. If the Power Transmitter does not to receive a Signal Strength Packet from the Power Receiver, the Power Transmitter shall remove the Power Signal as defined in *Parts 1 and 2: Interface Definitions*. The Power Transmitter may reapply the Power Signal multiple times at other-consecutively lower-Operating Frequencies within the range specified above, until the Power Transmitter receives a Signal Strength Packet containing an appropriate Signal Strength Value.

Figure 38. Electrical diagram (outline) of Power Transmitter design A12

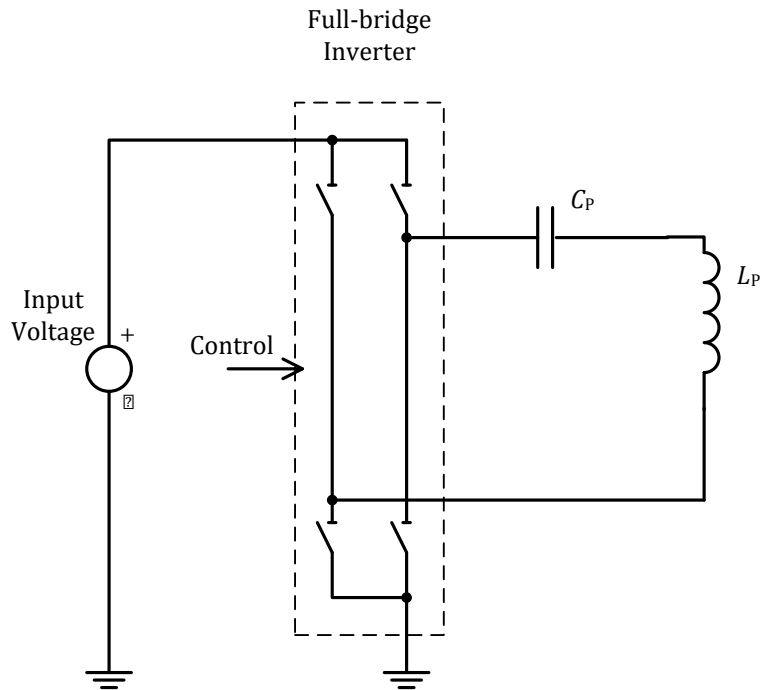

Control of the power transfer shall proceed using the PID algorithm, which is defined in *Parts 1 and 2: Interface Definitions*. The controlled variable $v^{(i)}$ introduced in the definition of that algorithm represents Operating Frequency or duty cycle. In order to guarantee sufficiently accurate power control, a type A12 Power Transmitter shall determine the amplitude of the Primary Cell current—which is equal to the Primary Coil current—with a resolution of 5 mA or better. Finally, Table 26 and Table 27 provide the values of several parameters, which are used in the PID algorithm.

Table 26. PID parameters for Operating Frequency control

Parameter	Symbol	Value	Unit
Proportional gain	K_p	1	mA^{-1}
Integral gain	K_i	0	$\text{mA}^{-1}\text{ms}^{-1}$
Derivative gain	K_d	0	mA^{-1}ms
Integral term limit	M_i	N.A.	N.A.
PID output limit	M_{PID}	20,000	N.A.
Scaling factor	S_v	1.0	Hz

Table 27. PID parameters for duty cycle control

Parameter	Symbol	Value	Unit
Proportional gain	K_p	1	mA^{-1}
Integral gain	K_i	0	$\text{mA}^{-1}\text{ms}^{-1}$
Derivative gain	K_d	0	mA^{-1}ms
Integral term limit	M_I	N.A.	N.A.
PID output limit	M_{PID}	20,000	N.A.
Scaling factor	S_v	0.1	%

2.2.13 Power Transmitter design A13

Figure 39 illustrates the functional block diagram of Power Transmitter design A13, which consists of two major functional units, namely a Power Conversion Unit and a Communications and Control Unit.

Figure 39. Functional block diagram of Power Transmitter design A13

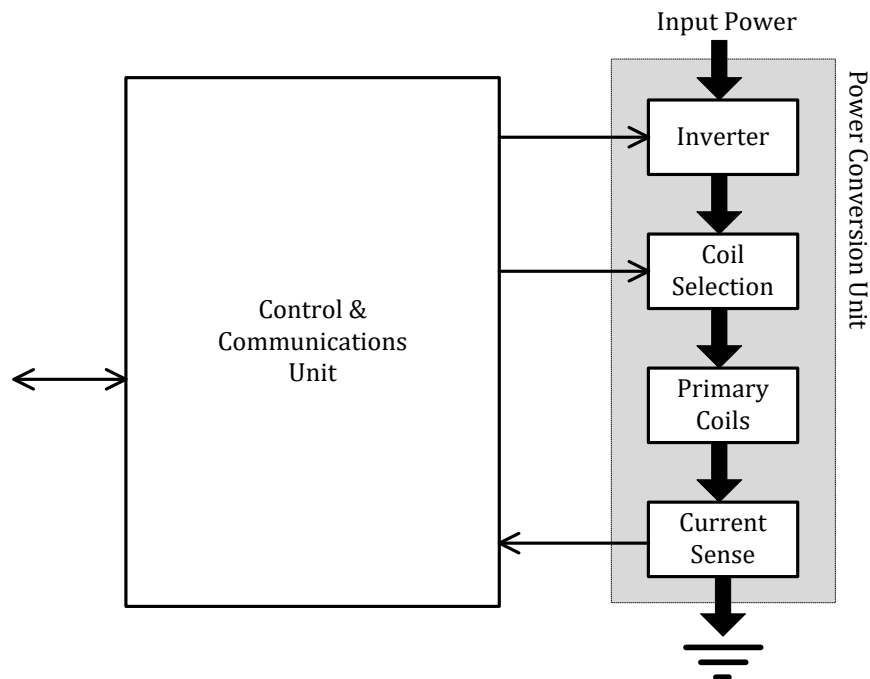

The Power Conversion Unit on the right-hand side of Figure 39 comprises the analog parts of the design. The inverter converts the DC input to an AC waveform that drives a resonant circuit, which consists of the selected Primary Coil plus a series capacitor. The selected Primary Coil is one from a linear array of partially overlapping Primary Coils, as appropriate for the position of the Power Receiver relative to the Primary Coils. Selection of the Primary Coil proceeds by the Power Transmitter attempting to establish communication with a Power Receiver using any of the Primary Coils. Note that the array may consist of a single Primary Coil only, in which case the selection is trivial. Finally, the current sense monitors the Primary Coil current.

The Communications and Control Unit on the left-hand side of Figure 39 comprises the digital logic part of the design. This unit receives and decodes messages from the Power Receiver, configures the Coil Selection block to connect the appropriate Primary Coil, executes the relevant power control algorithms and protocols, and drives the frequency of the AC waveform to control the power transfer. The Communications and Control Unit also interfaces with other subsystems of the Base Station, e.g. for user interface purposes.

2.2.13.1 Mechanical details

Power Transmitter design A13 includes one or more Primary Coils as defined in Section 2.2.13.1.1, Shielding as defined in Section 2.2.13.1.2, an Interface Surface as defined in Section 2.2.13.1.3.

2.2.13.1.1 Primary Coil

The Primary Coil is of the wire-wound type, and consists of no. 17 AWG (1.15 mm diameter) type 2 litz wire having 105 strands of no. 40 AWG (0.08 mm diameter), or equivalent. As shown in Figure 40, the Primary Coil has a rectangular shape and consists of a single layer. Table 28 lists the dimensions of the Primary Coil.

Figure 40. Primary Coil of Power Transmitter design A13

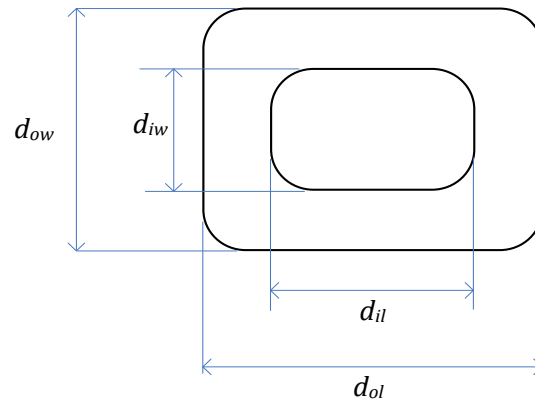
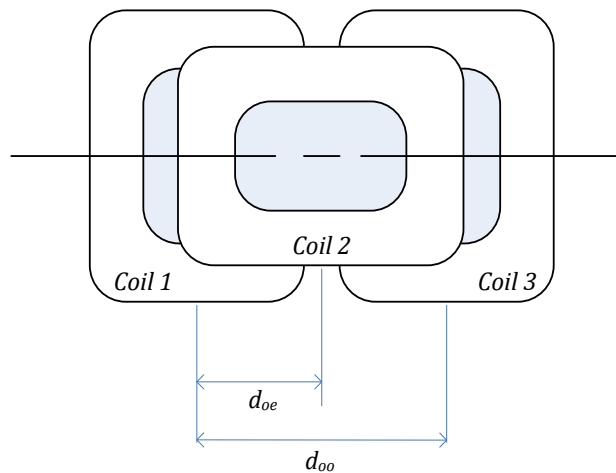

Table 28. Primary Coil parameters of Power Transmitter design A13

Parameter	Symbol	Value
Outer length	d_{ol}	$53.2^{\pm 0.5}$ mm
Inner length	d_{il}	$27.5^{\pm 0.5}$ mm
Outer width	d_{ow}	$45.2^{\pm 0.5}$ mm
Inner width	d_{iow}	$19.5^{\pm 0.5}$ mm
Thickness	d_c	$1.5^{\pm 0.5}$ mm
Number of turns per layer	N	12 turns
Number of layers	-	1

Power Transmitter design A13 contains at least one Primary Coil. Odd numbered coils are placed alongside each other with a displacement of $d_{oo} = 49.2^{\pm 4}$ mm between their centers. Even numbered coils are placed orthogonal to the odd numbered coils with a displacement of $d_{oe} = 24.6^{\pm 2}$ mm between their centers. See Figure 41.

Figure 41. Primary Coils of Power Transmitter design A13



2.2.13.1.2 Shielding

As shown in Figure 42, Shielding protects the Base Station from the magnetic field that is generated in the Primary Coil. The Shielding should be Ni-Zn or Mn-Zn ferrite and should be at least 0.5 mm thick. The Shielding extends to at least the outer dimensions of the Primary Coils, and is placed below the Primary Coil at a distance of at most $d_s = 1.0$ mm.

Figure 42. Primary Coil assembly of Power Transmitter design A13

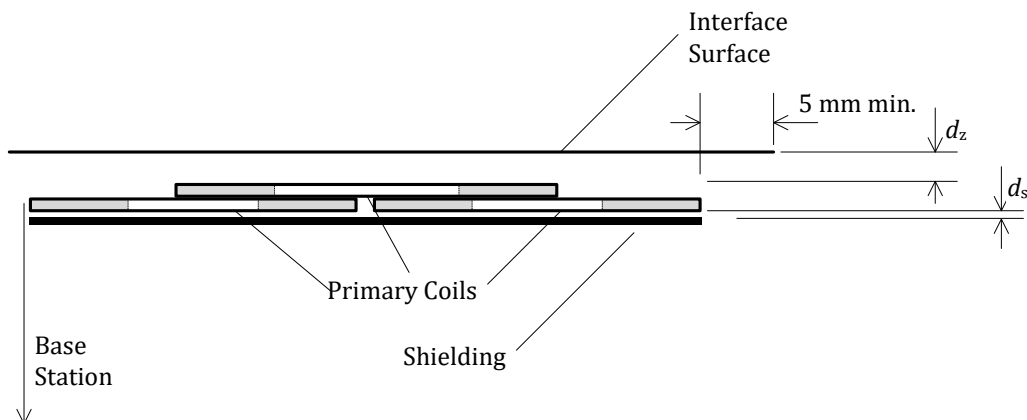

2.2.13.1.3 Interface Surface

As shown in Figure 42, the distance from the Primary Coil to the Interface Surface of the Base Station is $d_z = 3^{\pm 1}$ mm, across the top face of the Primary Coil. In the case of a single Primary Coil, the distance from the Primary Coil to the Interface Surface of the Base Station is $d_z = 4.5^{\pm 1}$ mm, across the top face of the Primary Coil. In addition, the Interface Surface of the Base Station extends at least 5 mm beyond the outer dimensions of the Primary Coils.

2.2.13.1.4 Inter coil separation

If the Base Station contains multiple type A13 Power Transmitters, the Primary Coils of any pair of those Power Transmitters shall have a center-to-center distance of at least $49.2^{\pm 4}$ mm.

2.2.13.2 Electrical details

As shown in Figure 43, Power Transmitter design A13 uses a full-bridge inverter to drive an individual Primary Coil and a series capacitance. Within the Operating Frequency range specified below, the assembly of Primary Coils and Shielding has a self inductance $L_p = 11.5^{\pm 10\%}$ μ H for coils closest to the Interface Surface and inductance $L_p = 12.5^{\pm 10\%}$ μ H for coils furthest from the Interface Surface. The value of inductances L_1 and L_2 is $1^{\pm 20\%}$ μ H. The value of the total series capacitance is $1/C_{ser1} + 1/C_{ser2} = 1/200^{\pm 10\%}$ 1/nF. The value of the parallel capacitance is $C_{par} = 400^{\pm 10\%}$ nF.

NOTE Near resonance, the voltage developed across the series capacitance can reach levels exceeding 100 V pk-pk.

Power Transmitter design A13 uses the input voltage of the inverter to control the amount of power that is transferred. For this purpose, the input voltage has a range of 1...12 V, with a resolution of 10 mV or better. The Operating Frequency is $f_{op} = 105 \dots 115$ kHz, with a duty cycle of 50%.

When a type A13 Power Transmitter first applies a Power Signal (Digital Ping; see *Parts 1 and 2: Interface Definitions*), it shall use an initial voltage of $3.5^{\pm 0.5}$ V for a bottom Primary Coil, and $3.0^{\pm 0.5}$ V for a top Primary Coil, and a recommended Operating Frequency of 110 kHz.

Control of the power transfer shall proceed using the PID algorithm, which is defined in *Parts 1 and 2: Interface Definitions*. The controlled variable $v^{(i)}$ introduced in the definition of that algorithm represents the input voltage to the inverter. In order to guarantee sufficiently accurate power control, a type A13 Power Transmitter shall determine the amplitude of the Primary Cell current—which is equal to the Primary Coil current—with a resolution of 7 mA or better. Finally, Table 29 provides the values of several parameters, which are used in the PID algorithm.

Figure 43. Electrical diagram (outline) of Power Transmitter design A13

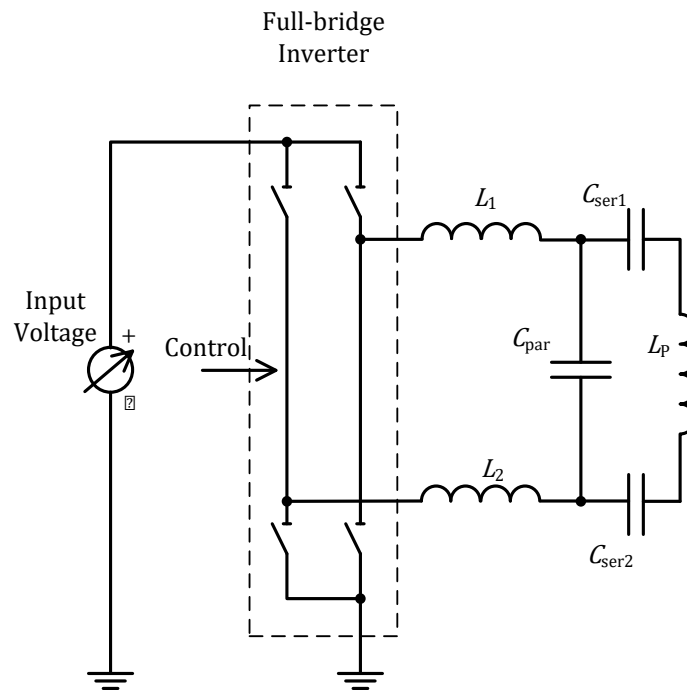

Table 29. PID parameters for voltage control

Parameter	Symbol	Value	Unit
Proportional gain	K_p	0.03	mA^{-1}
Integral gain	K_i	0.01	$\text{mA}^{-1}\text{ms}^{-1}$
Derivative gain	K_d	0	mA^{-1}ms
Integral term limit	M_i	3,000	N.A.
PID output limit	M_{PID}	20,000	N.A.
Scaling factor	S_v	-1	mV

2.2.14 Power Transmitter design A14

Figure 44 illustrates the functional block diagram of Power Transmitter design A14, which consists of two major functional units, namely a Power Conversion Unit and a Communications and Control Unit.

Figure 44. Functional block diagram of Power Transmitter design A14

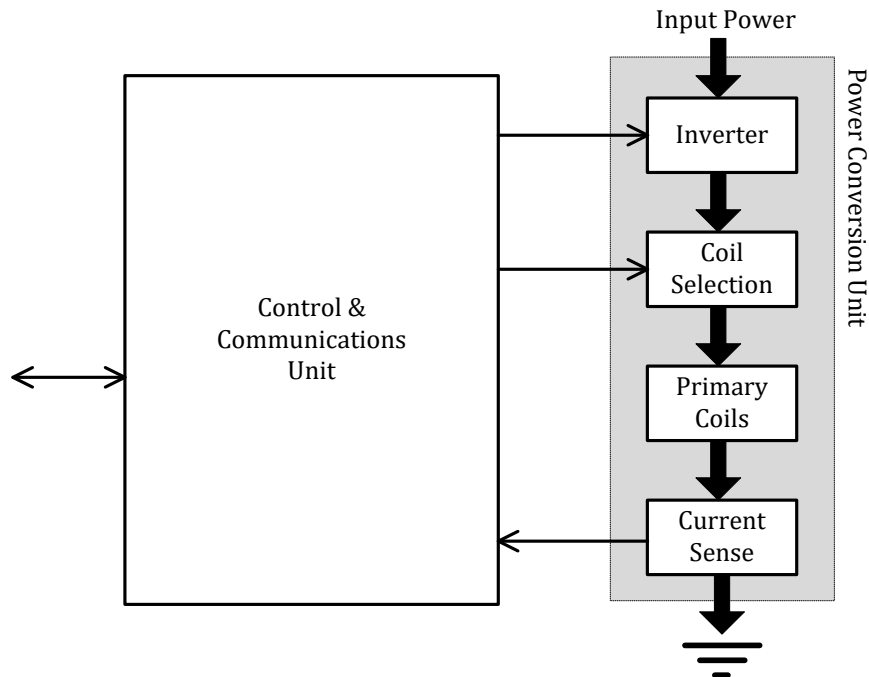

The Power Conversion Unit on the right-hand side of Figure 44 comprises the analog parts of the design. The inverter converts the DC input to an AC waveform that drives a resonant circuit, which consists of the selected Primary Coil plus a series capacitor. The selected Primary Coil is one from a linear array of partially overlapping Primary Coils, as appropriate for the position of the Power Receiver relative to the Primary Coils. Selection of the Primary Coil proceeds by the Power Transmitter attempting to establish communication with a Power Receiver using any of the Primary Coils. Note that the array may consist of a single Primary Coil only, in which case the selection is trivial. Finally, the current sense monitors the Primary Coil current.

The Communications and Control Unit on the left-hand side of Figure 44 comprises the digital logic part of the design. This unit receives and decodes messages from the Power Receiver, configures the Coil Selection block to connect the appropriate Primary Coil, executes the relevant power control algorithms and protocols, and drives the frequency of the AC waveform to control the power transfer. The Communications and Control Unit also interfaces with other subsystems of the Base Station, e.g. for user interface purposes.

2.2.14.1 Mechanical details

Power Transmitter design A14 includes one or more Primary Coils as defined in Section 2.2.14.1.1, Shielding as defined in Section 2.2.14.1.2, an Interface Surface as defined in Section 2.2.14.1.3.

2.2.14.1.1 Primary Coil

The Primary Coil is of the wire-wound type, and consists of litz wire having 115 strands of 0.08 mm diameter, or equivalent. As shown in Figure 45, the Primary Coil has a racetrack-like shape and consists of a single layer. Table 30 lists the dimensions of the Primary Coil.

Figure 45. Primary Coil of Power Transmitter design A14

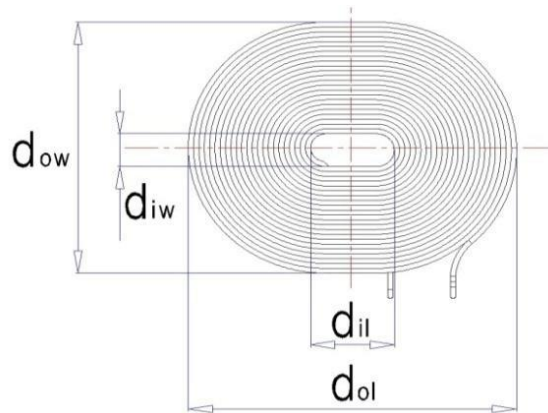
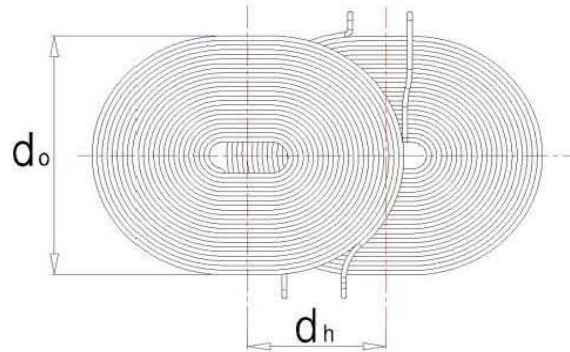

Table 30. Primary Coil parameters of Power Transmitter design A14

Parameter	Symbol	Value
Outer length	d_{ol}	$70^{\pm 0.5}$ mm
Inner length	d_{il}	$16^{\pm 1.0}$ mm
Outer width	d_{ow}	$59^{\pm 0.5}$ mm
Inner width	d_{iw}	$4.5^{\pm 0.5}$ mm
Thickness	d_c	$1.3^{\pm 0.1}$ mm
Number of turns per layer	N	23.5
Number of layers	–	1

Power Transmitter design A14 contains two Primary Coils, which are mounted in a Shielding block (see Section 2.2.14.1.2) with their long axes coincident, and a displacement of $d_h = 38^{\pm 0.5}$ mm between their centers. See Figure 46.

Figure 46. Primary Coils of Power Transmitter design A14



2.2.14.1.2 Shielding

As shown in Figure 47, Shielding protects the Base Station from the magnetic field that is generated in the Primary Coil. The Shielding should be Ni-Zn or Mn-Zn ferrite and should be at least 4.7 mm thick.

The top face of the Shielding block is aligned with the top face of the Primary Coils, such that the Shielding surrounds the Primary Coils on all sides except for the top face. In addition, the Shielding extends to at least 2.5 mm beyond the outer edge of the Primary Coils.

Figure 47. Primary Coil assembly of Power Transmitter design A14

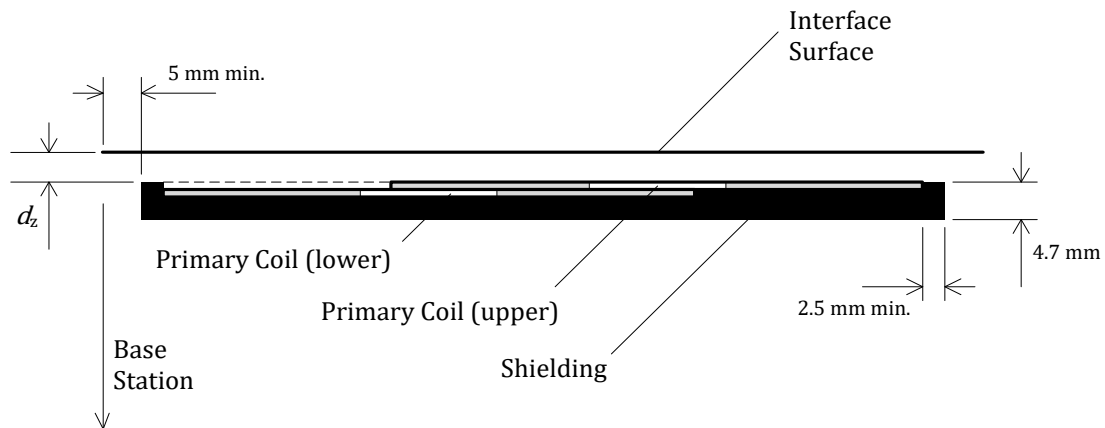

2.2.14.1.3 Interface Surface

As shown in Figure 47, the distance from the Primary Coil to the Interface Surface of the Base Station is $d_z = 2.0^{\pm 0.5}$ mm, across the top face of the Primary Coil. In addition, the Interface Surface of the Base Station extends at least 5 mm beyond the outer edges of the Primary Coils.

2.2.14.1.4 Inter coil separation

If the Base Station contains multiple type A14 Power Transmitters, the Primary Coils of any pair of those Power Transmitters shall have a center-to-center distance of at least 70 mm.

2.2.14.2 Electrical details

As shown in Figure 48, Power Transmitter design A14 uses a full-bridge inverter to drive the Primary Coils and a series capacitance. In addition, Power Transmitter design A14 shall operate coil selection switches SWu and SWl such that only a single Primary Coil is connected to the inverter.

Within the Operating Frequency range Specified below, the assembly of Primary Coils and Shielding has a self inductance $L_p = 24^{\pm 1.0}$ μ H. The value of the series capacitance is $C_p = 100^{\pm 5\%}$ nF. The input voltage to the full-bridge inverter is $12^{\pm 10\%}$ V.

NOTE Near resonance, the voltage developed across the series capacitance can reach levels up to 100 Vpk-pk.

Power Transmitter design A14 uses the Operating Frequency and duty cycle of the full-bridge inverter to control the amount of power that is transferred. For this purpose, the Operating Frequency range of the full-bridge inverter is $f_{op} = 110 \dots 205$ kHz with a duty cycle of 50% and its duty cycle range is 2...50% at an Operating Frequency of 110...205 kHz. A higher Operating Frequency and lower duty cycle result in the transfer of a lower amount of power. In order to achieve a sufficiently accurate adjustment of the power that is transferred, a type A14 Power Transmitter shall be able to control the frequency with a resolution of 0.5 kHz or better, and the duty cycle of the Power Signal with a resolution of 0.1% or better.

When a type A14 Power Transmitter first applies a Power Signal (Digital Ping; see *Parts 1 and 2: Interface Definitions*), the Power Transmitter shall use an initial Operating Frequency of 142 kHz, and a duty cycle of 50%. If the Power Transmitter does not to receive a Signal Strength Packet from the Power Receiver, the Power Transmitter shall remove the Power Signal as defined in *Parts 1 and 2: Interface Definitions*. The Power Transmitter may reapply the Power Signal multiple times at other-consecutively lower-Operating Frequencies within the range specified above, until the Power Transmitter receives a Signal Strength Packet containing an appropriate Signal Strength Value.

Figure 48. Electrical diagram (outline) of Power Transmitter design A14

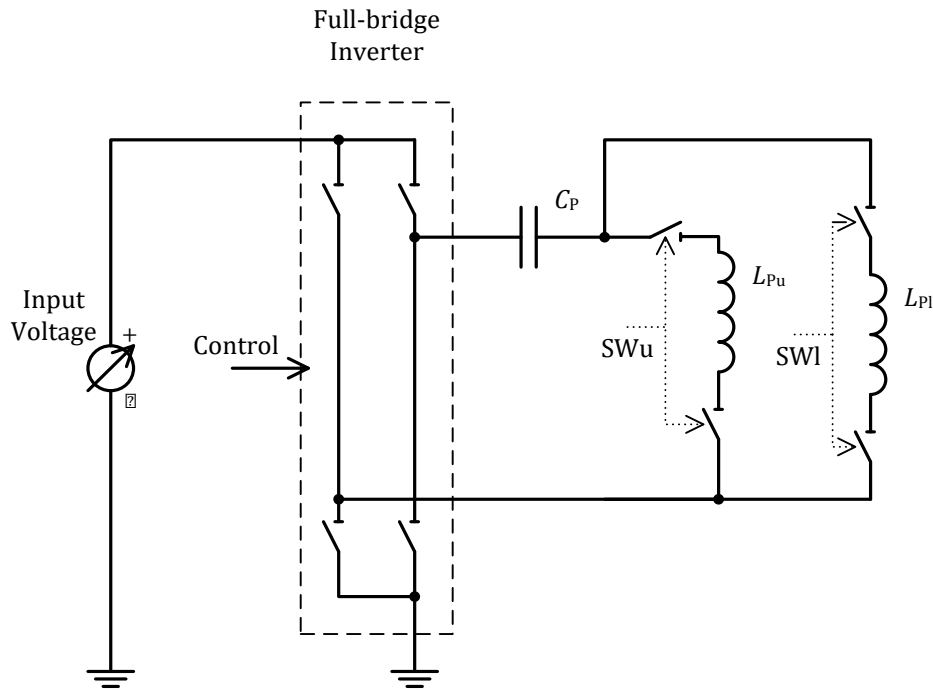

Control of the power transfer shall proceed using the PID algorithm, which is defined in Section *Parts 1 and 2: Interface Definitions*. The controlled variable $v^{(i)}$ introduced in the definition of that algorithm represents Operating Frequency or duty cycle. In order to guarantee sufficiently accurate power control, a type A14 Power Transmitter shall determine the amplitude of the Primary Cell current—which is equal to the Primary Coil current—with a resolution of 5 mA or better. Finally, Table 31 and Table 32 provide the values of several parameters, which are used in the PID algorithm.

Table 31. PID parameters for Operating Frequency control

Parameter	Symbol	Value	Unit
Proportional gain	K_p	1	mA^{-1}
Integral gain	K_i	0	$\text{mA}^{-1}\text{ms}^{-1}$
Derivative gain	K_d	0	mA^{-1}ms
Integral term limit	M_i	N.A.	N.A.
PID output limit	M_{PID}	20,000	N.A.
Scaling factor	S_v	1.0	Hz

Table 32. PID parameters for duty cycle control

Parameter	Symbol	Value	Unit
Proportional gain	K_p	1	mA^{-1}
Integral gain	K_i	0	$\text{mA}^{-1}\text{ms}^{-1}$
Derivative gain	K_d	0	mA^{-1}ms
Integral term limit	M_I	N.A.	N.A.
PID output limit	M_{PID}	20,000	N.A.
Scaling factor	S_v	0.1	%

2.2.15 Power Transmitter design A15

Figure 49 illustrates the functional block diagram of Power Transmitter design A15, which consists of three major functional units, namely a Power Conversion Unit, a Detection Unit, and a Communications and Control Unit.

Figure 49. Functional block diagram of Power Transmitter design A15

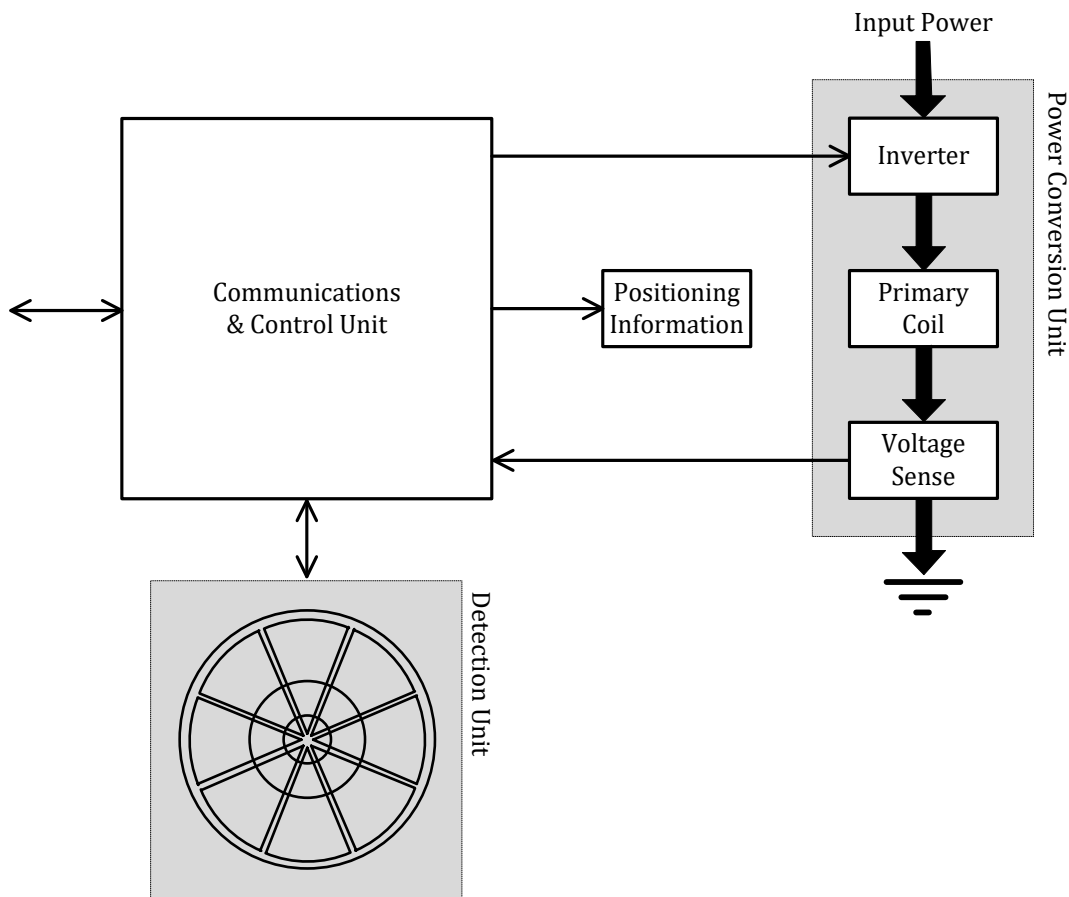

The Power Conversion Unit on the right-hand side of Figure 49 and the Detection Unit at the bottom of Figure 49 comprises the analog parts of the design. The inverter converts the DC input to an AC waveform that drives a resonant circuit, which consists of the Primary Coil plus a series capacitor. Finally, the voltage sense monitors the Primary Coil voltage.

The Communications and Control Unit on the left-hand side of Figure 49 comprises the digital logic part of the design. This unit receives and decodes messages from the Power Receiver, executes the relevant power control algorithms and protocols, and drives the frequency of the AC waveform to control the power transfer. The Communications and Control Unit also interfaces with other subsystems of the Base Station, e.g. for user interface purposes.

The Detection Unit determines the approximate location of objects and/or Power Receivers on the Interface Surface. This version of *Part 4: Reference Designs* does not specify a particular detection method. However, it is recommended that the Detection Unit exploits the resonance in the Power Receiver at the detection frequency f_d (see the *Power Receiver Design Requirements* section in *Parts 1 and 2: Interface Definitions*). The reason is that this approach minimizes movements of the Secondary Coil, because the Power Transmitter does not need to inform the user about objects that do not respond at this resonant frequency. *Parts 1 and 2: Interface Definitions* provides an example resonant detection method.

2.2.15.1 Mechanical details

Power Transmitter design A15 includes a single Primary Coil as defined in Section 2.2.15.1.1, Shielding as defined in Section 2.2.15.1.2, an Interface Surface as defined in Section 2.2.15.1.3, and an alignment aid as defined in Section 2.2.15.1.4.

2.2.15.1.1 Primary Coil

The Primary Coil is of the wire-wound type, and consists of litz wire having 100 strands of 0.08 mm diameter, or equivalent. As shown in Figure 50, the Primary Coil has a circular shape and consists of a single layer. Table 33 lists the dimensions of the Primary Coil.

NOTE This Primary Coil is identical to the Primary Coil of Power Transmitter Design A7.

Figure 50. Primary Coil of Power Transmitter design A15

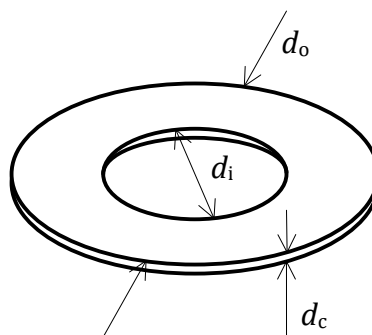

Table 33. Primary Coil parameters of Power Transmitter design A15

Parameter	Symbol	Value
Outer diameter	d_o	$39^{\pm 2}$ mm
Inner diameter	d_i	$12^{\pm 0.2}$ mm
Thickness	d_c	$1.9^{\pm 0.2}$ mm
Number of turns per layer	N	20
Number of layers	-	1

2.2.15.1.2 Shielding

As shown in Figure 51, Shielding protects the Base Station from the magnetic field that is generated in the Primary Coil. The Shielding should be Ni-Zn or Mn-Zn ferrite and should be at least 0.6 mm thick. The Shielding extends to at least 1 mm beyond the outer diameter of the Primary Coil, and is placed below the Primary Coil at a distance of at most $d_s = 1.5$ mm.

Figure 51. Primary Coil assembly of Power Transmitter design A15

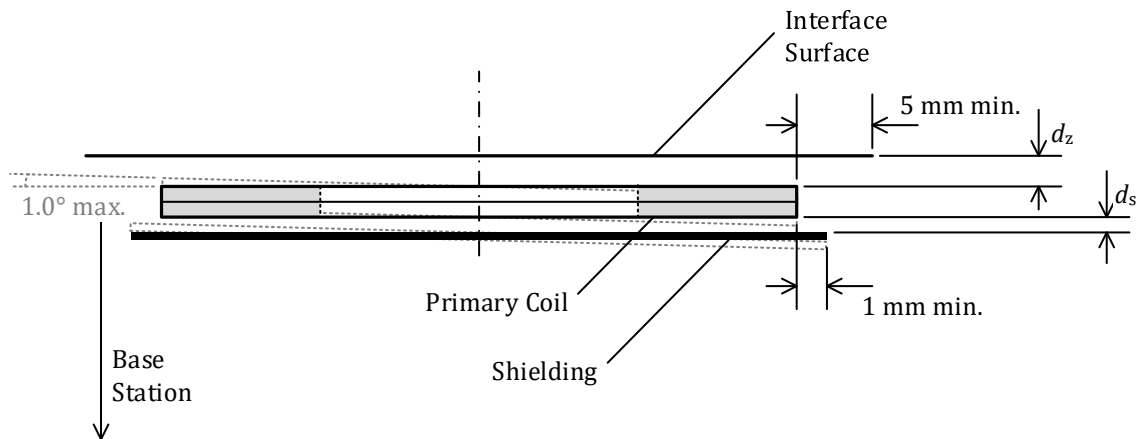

2.2.15.1.3 Interface Surface

As shown in Figure 51, the distance from the Primary Coil to the Interface Surface of the Base Station is $d_z = 3.0^{\pm 0.5}$ mm, across the top face of the Primary Coil. In addition, the Interface Surface of the Base Station extends at least 5 mm beyond the outer diameter of the Primary Coil.

2.2.15.1.4 Alignment aid

The alignment aid consists of a visual, audible or tactile indication, which helps a user to guide a Power Receiver into the Active Area of the Interface Surface by giving directional feedback.

NOTE *An example is a LED indicator, which shows at least two directions.*

2.2.15.2 Electrical details

As shown in Figure 52, Power Transmitter design A15 uses a full-bridge inverter to drive the Primary Coil and a series capacitance. At an Operating Frequency range between 105 kHz and 140 kHz, the assembly of Primary Coil and Shielding has a self inductance $L_p = 13.6^{\pm 10\%} \mu\text{H}$. The value of the series capacitance is $C_p = 180^{\pm 5\%} \text{nF}$.

NOTE Near resonance, the voltage developed across the series capacitance can reach levels up to 100 V pk-pk.

Power Transmitter design A15 uses the input voltage to the full-bridge inverter to control the amount of power that is transferred. For this purpose, the input voltage range is 3...12 V, where a lower input voltage results in the transfer of a lower amount of power. In order to achieve a sufficiently accurate adjustment of the power that is transferred, a type A15 Power Transmitter shall be able to control the input voltage with a resolution of 50 mV or better.

When a type A15 Power Transmitter first applies a Power Signal (Digital Ping; see *Parts 1 and 2: Interface Definitions*), it shall use an initial input voltage of 5.7 V. It is recommended that the Power Transmitter uses an Operating Frequency of 140 kHz when first applying the Power Signal. If the Power Transmitter does not receive a Signal Strength Packet from the Power Receiver, the Power Transmitter shall remove the Power Signal as defined in *Parts 1 and 2: Interface Definitions*. The Power Transmitter may reapply the Power Signal multiple times at other—consecutively lower—Operating Frequencies within the range specified above, until the Power Transmitter receives a Signal Strength Packet containing an appropriate Signal Strength Value.

Figure 52. Electrical diagram (outline) of Power Transmitter design A15

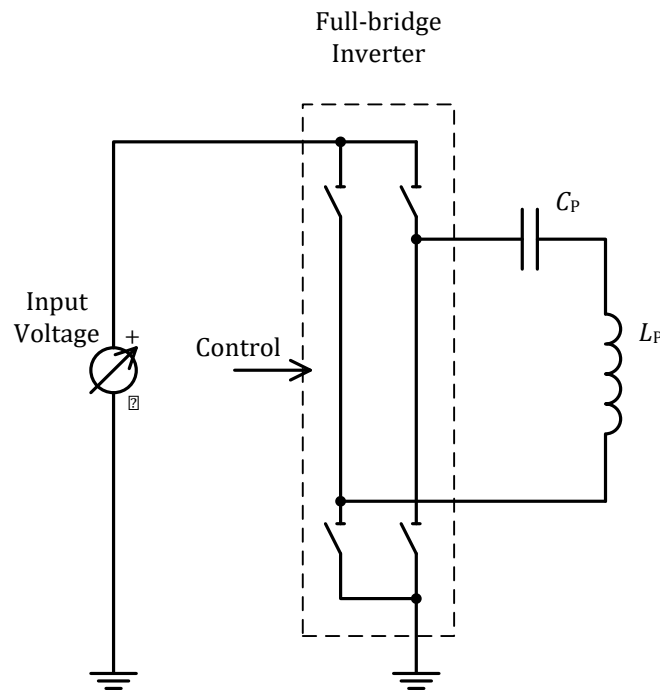

Control of the power transfer shall proceed using the PID algorithm, which is defined in Section *Parts 1 and 2: Interface Definitions*. The controlled variable $v^{(i)}$ introduced in the definition of that algorithm represents the input voltage to the full-bridge inverter. In order to guarantee sufficiently accurate power control, a type A15 Power Transmitter shall determine the amplitude of the Primary Cell voltage—which is equal to the Primary Coil voltage—with a resolution of 5 mV or better. Finally, Table 34 provides the values of several parameters, which are used in the PID algorithm.

Table 34. PID parameters for voltage control

Parameter	Symbol	Value	Unit
Proportional gain	K_p	1	mA^{-1}
Integral gain	K_i	0	$\text{mA}^{-1}\text{ms}^{-1}$
Derivative gain	K_d	0	mA^{-1}ms
Integral term limit	M_i	N.A.	N.A.
PID output limit	M_{PID}	1,500	N.A.
Scaling factor	S_v	-0.5	mV

2.2.16 Power Transmitter design A16

Figure 53 illustrates the functional block diagram of Power Transmitter design A16, which consists of two major functional units, namely a Power Conversion Unit and a Communications and Control Unit.

Figure 53. Functional block diagram of Power Transmitter design A16

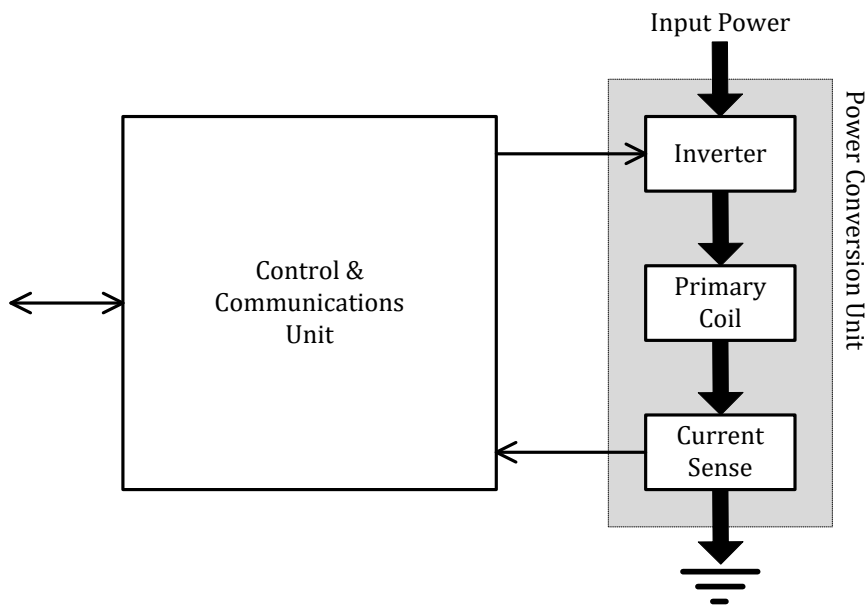

The Power Conversion Unit on the right-hand side of Figure 53 comprises the analog parts of the design. The inverter converts the DC input to an AC waveform that drives a resonant circuit, which consists of the Primary Coil plus a series capacitor. Finally, the current sense monitors the Primary Coil current.

The Communications and Control Unit on the left-hand side of Figure 53 comprises the digital logic part of the design. This unit receives and decodes messages from the Power Receiver, executes the relevant power control algorithms and protocols, and drives the frequency of the AC waveform to control the power transfer. The Communications and Control Unit also interfaces with other subsystems of the Base Station, e.g. for user interface purposes.

Product development based on Power Transmitter designs A16 is discouraged. The WPC have noticed that Power Transmitters based on this design underperform with Foreign Object Detection. The WPC therefore have decided to phase out the registration of new Base Station products based on this design. The exact cut-off date has not been decided yet.

2.2.16.1 Mechanical details

Power Transmitter design A16 includes a single Primary Coil as defined in Section 2.2.16.1.1, Shielding as defined in Section 2.2.16.1.2, an Interface Surface as defined in Section 2.2.16.1.3, and an alignment aid as defined in Section 2.2.16.1.4.

2.2.16.1.1 Primary Coil

The Primary Coil is of the wire-wound type, and consists of litz wire having 105 strands of no. 40 AWG (0.08 mm diameter), or equivalent. As shown in Figure 54, the Primary Coil has a triangular shape and consists of a single layer. Table 35 lists the dimensions of the Primary Coil.

Figure 54. Primary Coil of Power Transmitter design A16

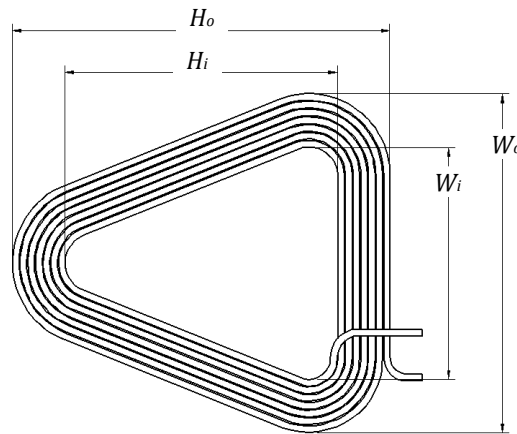

Table 35. Primary Coil parameters of Power Transmitter design A16

Parameter	Symbol	Value
Outer height	H_o	$59^{\pm 0.5}$ mm
Inner height	H_i	$43^{\pm 0.5}$ mm
Outer width	W_o	$52^{\pm 0.5}$ mm
Inner width	W_i	$36^{\pm 0.5}$ mm
Thickness	d_c	$1.1+0.3$ mm
Number of turns per layer	N	7
Number of layers	-	1

Product development based on Power Transmitter designs A16 is discouraged. The WPC have noticed that Power Transmitters based on this design underperform with Foreign Object Detection. The WPC therefore have decided to phase out the registration of new Base Station products based on this design. The exact cut-off date has not been decided yet.

2.2.16.1.2 Shielding

As shown in Figure 55, Shielding protects the Base Station from the magnetic field that is generated in the Primary Coil. The Shielding should be Ni-Zn or Mn-Zn ferrite and should be at least 0.5 mm thick. The Shielding extends to at least 2.5 mm beyond the outer diameter of the Primary Coil, and is placed below the Primary Coil at a distance of at most $d_s = 1.0$ mm.

Figure 55. Primary Coil assembly of Power Transmitter design A16

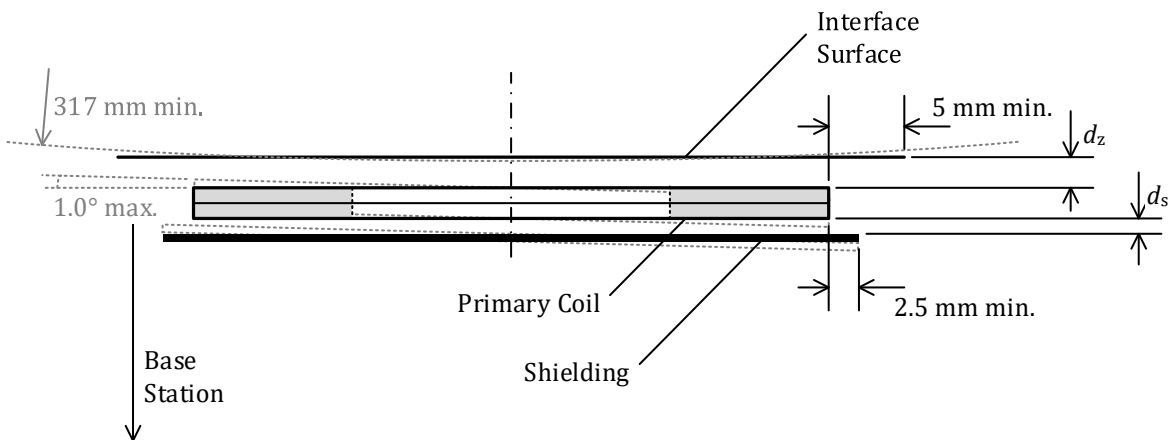

2.2.16.1.3 Interface Surface

As shown in Figure 55, the distance from the Primary Coil to the Interface Surface of the Base Station is $d_z = 2^{+0.5}_{-0.5}$ mm, across the top face of the Primary Coil. In addition, the Interface Surface of the Base Station extends at least 5 mm beyond the outer diameter of the Primary Coil.

NOTE This Primary-Coil-to-Interface-Surface distance implies that the tilt angle between the Primary Coil and a flat Interface Surface is at most 1.0° . Alternatively, in case of a non-flat Interface Surface, this Primary-Coil-to-Interface-Surface distance implies a radius of curvature of the Interface Surface of at least 317 mm, centered on the Primary Coil. See Figure 55.

Product development based on Power Transmitter designs A16 is discouraged. The WPC have noticed that Power Transmitters based on this design underperform with Foreign Object Detection. The WPC therefore have decided to phase out the registration of new Base Station products based on this design. The exact cut-off date has not been decided yet.

2.2.16.1.4 Alignment aid

The user manual of the Base Station containing a type A16 Power Transmitter shall have information about the location of its Active Area(s).

For the best user experience, it is recommended to employ at least one user feedback mechanism during Mobile Device positioning to help alignment.

NOTE Examples of Base Station alignment aids to assist the user positioning of the Mobile Device include:

- A marked Interface Surface to indicate the location of the Active Area(s)—e.g. by means of the logo or other visual marking, lighting, etc.
- A visual feedback display—e.g. by means of illuminating an LED to indicate proper alignment.
- An audible or haptic feedback mechanism.

2.2.16.1.5 Inter coil separation

If the Base Station contains multiple type A16 Power Transmitters, the Primary Coils of any pair of those Power Transmitters shall not overlap.

2.2.16.2 Electrical details

As shown in Figure 56, Power Transmitter design A16 uses a full-bridge inverter to drive the Primary Coil and a series capacitance. Within the Operating Frequency range specified below, the assembly of Primary Coil, Shielding, and magnet has a self inductance $L_p = 6.3^{\pm 10\%}$ μH . The value of the series capacitance is $C_p = 0.4^{\pm 5\%}$ μF . The input voltage to the full-bridge inverter is $5^{\pm 5\%}$ V.

NOTE Near resonance, the voltage developed across the series capacitance can reach levels exceeding 100 V pk-pk.

Power Transmitter design A16 uses the Operating Frequency and duty cycle of the Power Signal in order to control the amount of power that is transferred. For this purpose, the Operating Frequency range of the full-bridge inverter is $f_{op} = 110 \dots 205$ kHz with a duty cycle of 50%; and its duty cycle range is 10...50% at an Operating Frequency of 205 kHz. A higher Operating Frequency or lower duty cycle result in the transfer of a lower amount of power. In order to achieve a sufficiently accurate adjustment of the amount of power that is transferred, a type A16 Power Transmitter shall control the Operating Frequency with a resolution of

- $0.01 \times f_{op} - 0.7$ kHz, for f_{op} in the 110...175 kHz range;
- $0.015 \times f_{op} - 1.58$ kHz, for f_{op} in the 175...205 kHz range;

or better. In addition, a type A16 Power Transmitter shall control the duty cycle of the Power Signal with a resolution of 0.1% or better.

Product development based on Power Transmitter designs A16 is discouraged. The WPC have noticed that Power Transmitters based on this design underperform with Foreign Object Detection. The WPC therefore have decided to phase out the registration of new Base Station products based on this design. The exact cut-off date has not been decided yet.

When a type A16 Power Transmitter first applies a Power Signal (Digital Ping; see *Parts 1 and 2: Interface Definitions*), it shall use an initial Operating Frequency of 175 kHz (and a duty cycle of 50%).

Control of the power transfer shall proceed using the PID algorithm, which is defined in *Parts 1 and 2: Interface Definitions*. The controlled variable $v^{(i)}$ introduced in the definition of that algorithm represents the Operating Frequency or the duty cycle. In order to guarantee sufficiently accurate power control, a type A16 Power Transmitter shall determine the amplitude of the Primary Cell current—which is equal to the Primary Coil current—with a resolution of 7 mA or better. Finally, Table 36, Table 37, and Table 38 provide the values of several parameters, which are used in the PID algorithm.

Figure 56. Electrical diagram (outline) of Power Transmitter design A16

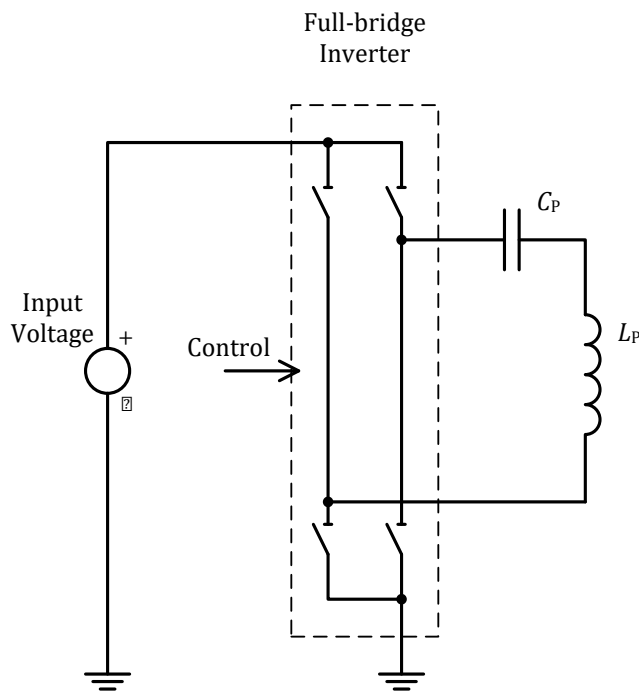

Product development based on Power Transmitter designs A16 is discouraged. The WPC have noticed that Power Transmitters based on this design underperform with Foreign Object Detection. The WPC therefore have decided to phase out the registration of new Base Station products based on this design. The exact cut-off date has not been decided yet.

Table 36. PID parameters for Operating Frequency control

Parameter	Symbol	Value	Unit
Proportional gain	K_p	10	mA^{-1}
Integral gain	K_i	0.05	$\text{mA}^{-1}\text{ms}^{-1}$
Derivative gain	K_d	0	mA^{-1}ms
Integral term limit	M_i	3,000	N.A.
PID output limit	M_{PID}	20,000	N.A.

Table 37. Operating Frequency dependent scaling factor

Frequency Range [kHz]	Scaling Factor S_v [Hz]
110...140	1.5
140...160	2
160...180	3
180...205	5

Table 38. PID parameters for duty cycle control

Parameter	Symbol	Value	Unit
Proportional gain	K_p	10	mA^{-1}
Integral gain	K_i	0.05	$\text{mA}^{-1}\text{ms}^{-1}$
Derivative gain	K_d	0	mA^{-1}ms
Integral term limit	M_i	3,000	N.A.
PID output limit	M_{PID}	20,000	N.A.
Scaling factor	S_v	-0.01	%

Product development based on Power Transmitter designs A16 is discouraged. The WPC have noticed that Power Transmitters based on this design underperform with Foreign Object Detection. The WPC therefore have decided to phase out the registration of new Base Station products based on this design. The exact cut-off date has not been decided yet.

2.2.17 Power Transmitter design A17

Power Transmitter design A17 enables Guided Positioning. Figure 57 illustrates the functional block diagram of this design, which consists of two major functional units, namely a Power Conversion Unit and a Communications and Control Unit.

Figure 57. Functional block diagram of Power Transmitter design A17

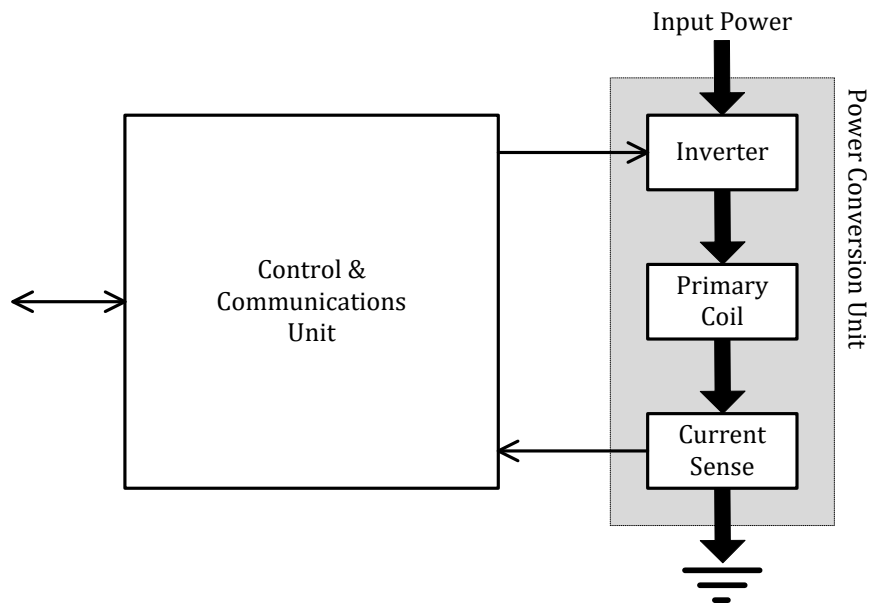

The Power Conversion Unit on the right-hand side of Figure 57 comprises the analog parts of the design. The inverter converts the DC input to an AC waveform that drives a resonant circuit, which consists of the Primary Coil plus one or more capacitors. Finally, the current sense monitors the Primary Coil current.

The Communications and Control Unit on the left-hand side of Figure 57 comprises the digital logic part of the design. This unit receives and decodes messages from the Power Receiver, executes the relevant power control algorithms and protocols, and drives the rail voltage of the AC waveform to control the power transfer. The Communications and Control Unit also interfaces with other subsystems of the Base Station, e.g. for user interface purposes.

2.2.17.1 Mechanical details

Power Transmitter design A17 includes a single Primary Coil as defined in Section 2.2.17.1.1, Shielding as defined in Section 2.2.17.1.2, an Interface Surface as defined in Section 2.2.17.1.3, and an alignment aid as defined in Section 2.2.17.1.4.

2.2.17.1.1 Primary Coil

The Primary Coil is of the wire-wound type, and consists of no. 17 AWG (1.15 mm diameter) type 2 litz wire having 105 strands of no. 40 AWG (0.08 mm diameter), or equivalent. As shown in Figure 58, the Primary Coil has a circular shape and consists of multiple layers. All layers are stacked with the same polarity. Table 39 lists the dimensions of the Primary Coil.

Figure 58. Primary Coil of Power Transmitter design A17

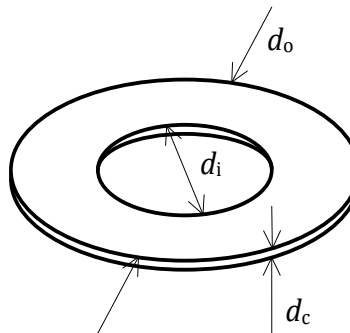

Table 39. Primary Coil parameters of Power Transmitter design A17

Parameter	Symbol	Value
Outer diameter	d_o	$43^{\pm 0.5}$ mm
Inner diameter	d_i	$20.5^{\pm 0.5}$ mm
Thickness	d_c	$2.1^{+0.5}$ mm
Number of turns per layer	N	10
Number of layers	-	2

2.2.17.1.2 Shielding

As shown in Figure 59, Shielding protects the Base Station from the magnetic field that is generated in the Primary Coil. The Shielding should be Ni-Zn or Mn-Zn ferrite and should be at least 0.5 mm thick. The Shielding extends to at least 2 mm beyond the outer diameter of the Primary Coil, and is placed below the Primary Coil at a distance of at most $d_s = 1.0$ mm.

Figure 59. Primary Coil assembly of Power Transmitter design A17

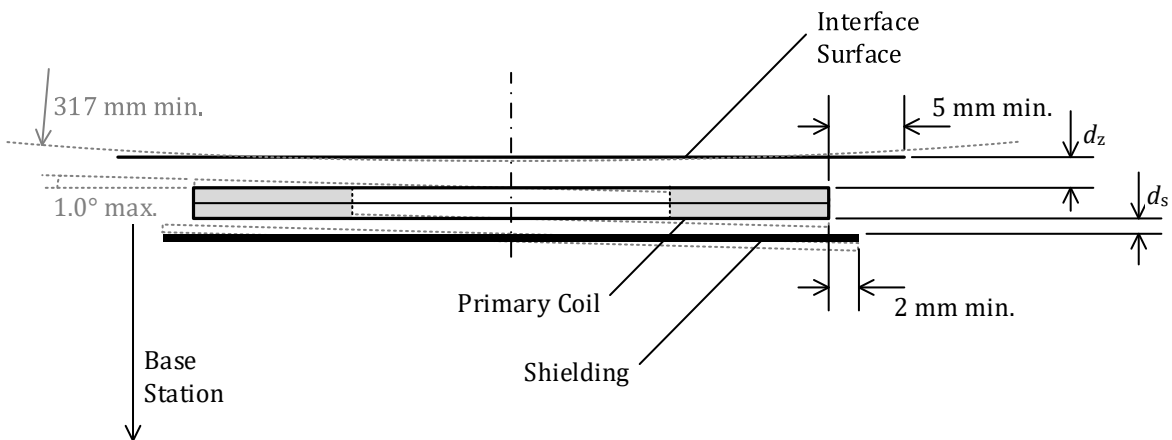

2.2.17.1.3 Interface Surface

As shown in Figure 59, the distance from the Primary Coil to the Interface Surface of the Base Station is $d_z = 7^{+0.5}_{-5.25}$ mm, across the top face of the Primary Coil. In addition, the Interface Surface of the Base Station extends at least 5 mm beyond the outer diameter of the Primary Coil.

NOTE This Primary-Coil-to-Interface-Surface distance implies that the tilt angle between the Primary Coil and a flat Interface Surface is at most 1.0°. Alternatively, in case of a non-flat Interface Surface, this Primary-Coil-to-Interface-Surface distance implies a radius of curvature of the Interface Surface of at least 317 mm, centered on the Primary Coil. See Figure 59.

2.2.17.1.4 Alignment aid

The user manual of the Base Station containing a type A17 Power Transmitter shall have information about the location of its Active Area(s).

For the best user experience, it is recommended to employ at least one user feedback mechanism during Mobile Device positioning to help alignment.

NOTE Examples of Base Station alignment aids to assist the user positioning of the Mobile Device include:

- A marked Interface Surface to indicate the location of the Active Area(s)—e.g. by means of the logo or other visual marking, lighting, etc.
- A visual feedback display—e.g. by means of illuminating an LED to indicate proper alignment.
- An audible or haptic feedback mechanism.

2.2.17.1.5 Inter coil separation

If the Base Station contains multiple type A17 Power Transmitters, the Primary Coils of any pair of those Power Transmitters shall have a center-to-center distance of at least 50 mm.

2.2.17.2 Electrical details

As shown in Figure 60, Power Transmitter design A17 uses a full-bridge inverter to drive the resonant network including filter inductors, a primary Coil with a series and parallel capacitance. Within the Operating Frequency range specified below, the assembly of Primary Coil and Shielding has a self-inductance $L_p = 24^{\pm 10\%}$ μH . The value of inductances L_1 and L_2 is $2.2^{\pm 20\%}$ μH . The value of the total series capacitance is $C_{ser1} + C_{ser2} = 100^{\pm 5\%}$ nF, where the individual series capacitances may have any value less than the sum. The value of the parallel capacitance is $C_{par} = 200^{\pm 5\%}$ nF.

NOTE Near resonance, the voltage developed across the series capacitance can reach levels exceeding 100 V pk-pk.

Power Transmitter design A17 uses the input voltage to the inverter to control the amount of power transferred. For this purpose, the input voltage has a range 1.4...15 V, with a resolution of 10 mV or better; a higher input voltage results in more power transferred. The Operating Frequency is $f_{op} = 105 \dots 116$ kHz with a duty cycle of 50%

When a type A17 Power Transmitter first applies a Power Signal (Digital Ping; see *Parts 1 and 2: Interface Definitions*), it shall use an input voltage of 5.75 V, and a recommended Operating Frequency of 111 kHz.

Control of the power transfer shall proceed using the PID algorithm, which is defined in *Parts 1 and 2: Interface Definitions*. The controlled variable $v^{(i)}$ introduced in the definition of that algorithm represents the input voltage. In order to guarantee sufficiently accurate power control, a type A17 Power Transmitter shall determine the amplitude of the Primary Cell current—which is equal to the Primary Coil current—with a resolution of 7 mA or better. Finally, Table 40 provides the values of several parameters, which are used in the PID algorithm.

Figure 60. Electrical diagram (outline) of Power Transmitter design A17

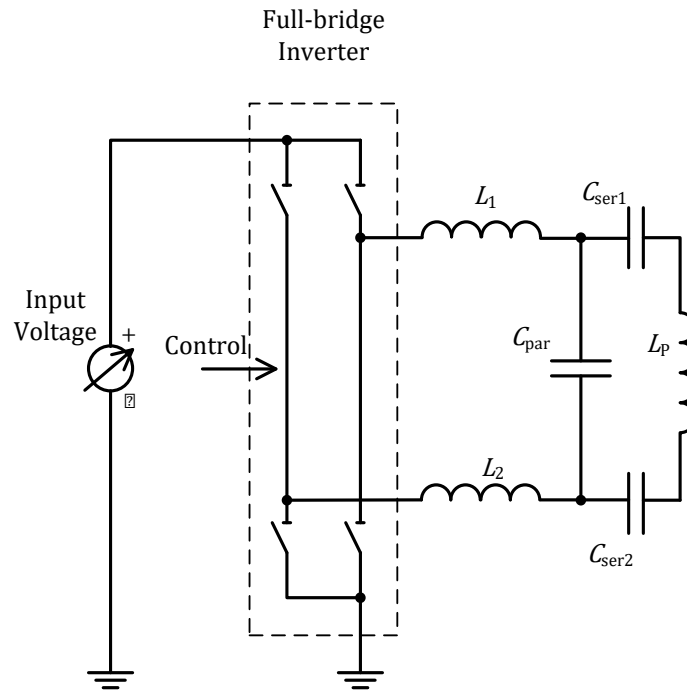

Table 40. PID parameters for voltage control

Parameter	Symbol	Value	Unit
Proportional gain	K_p	10	mA^{-1}
Integral gain	K_i	1	$\text{mA}^{-1}\text{ms}^{-1}$
Derivative gain	K_d	1	mA^{-1}ms
Integral term limit	M_I	3,000	N.A.
PID output limit	M_{PID}	20,000	N.A.
Scaling factor	S_v	200	mV

2.2.18 Power Transmitter design A18

Figure 61 illustrates the functional block diagram of this design, which consists of three major functional units, namely a Power Conversion Unit, a Detection Unit, and a Communications and Control Unit.

Figure 61. Functional block diagram of Power Transmitter design A18

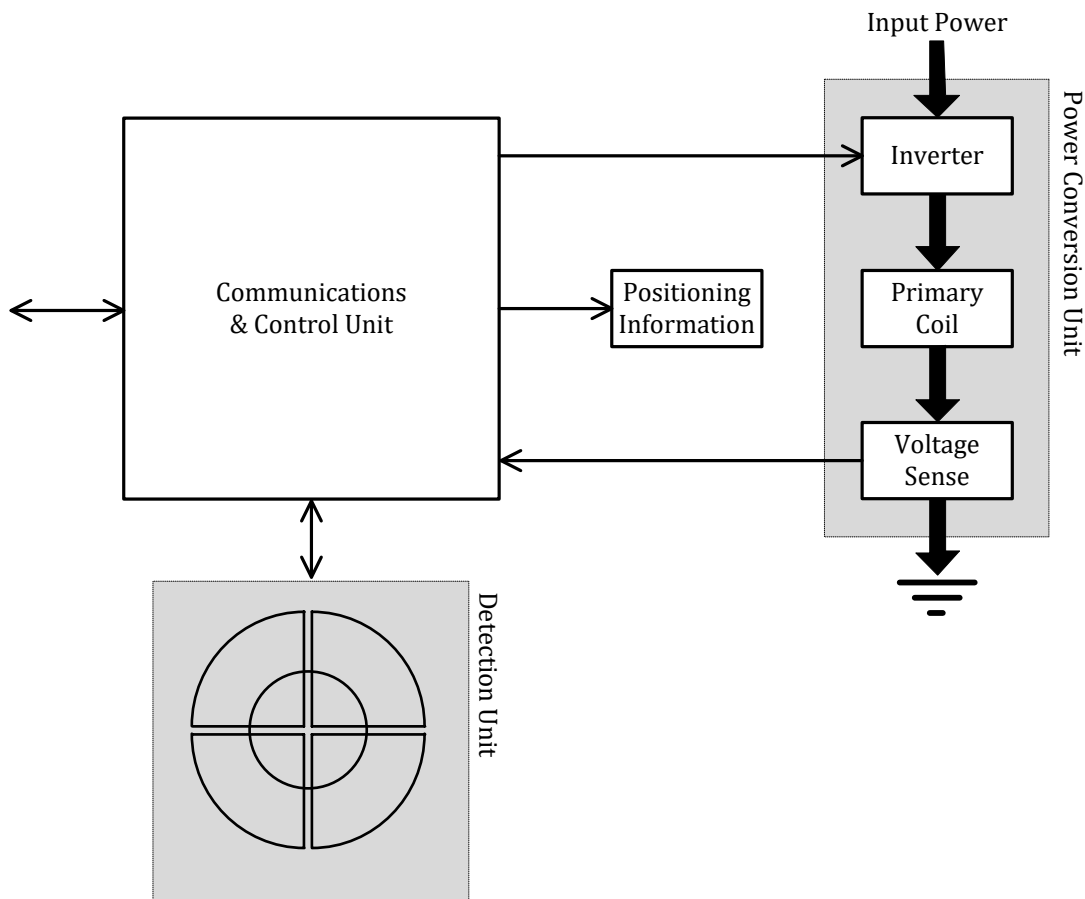

The Power Conversion Unit on the right-hand side of Figure 61 and the Detection Unit of the bottom of Figure 61 comprise the analog parts of the design. The Power Conversion Unit is similar to the Power Conversion Unit of Power Transmitter design A7. The inverter converts the DC input to an AC waveform that drives a resonant circuit, which consists of the Primary Coil plus a series capacitor. Finally, the voltage sense monitors the Primary Coil voltage.

The Communications and Control Unit on the left-hand side of Figure 61 comprises the digital logic part of the design. This unit is similar to the Communications and Control Unit of Power Transmitter design A7. The Communications and Control Unit receives and decodes messages from the Power Receiver, executes the relevant power control algorithms and protocols, and drives the input voltage of the AC waveform to control the power transfer. The Communications and Control Unit also interfaces with other subsystems of the Base Station, e.g. for user interface purposes.

The Detection Unit determines the approximate location of objects and/or Power Receivers on the Interface Surface. This version of *Part 4: Reference Designs* does not specify a particular detection method. However, it is recommended that the Detection Unit exploits the resonance in the Power Receiver at the detection frequency f_d (see the *Power Receiver Design Requirements* section in *Parts 1 and 2: Interface Definitions*). The reason is that this approach minimizes movements of the Secondary Coil, because the Power Transmitter does not need to inform the user about objects that do not respond at this resonant frequency. *Parts 1 and 2: Interface Definitions* provides an example resonant detection method.

2.2.18.1 Mechanical details

Power Transmitter design A18 includes a single Primary Coil as defined in Section 2.2.18.1.1, Shielding as defined in Section 2.2.18.1.2, an Interface Surface as defined in Section 2.2.18.1.3, and an alignment aid as defined in Section 2.2.18.1.4.

2.2.18.1.1 Primary Coil

The Primary Coil is of the wire-wound type, and consists of litz wire having 80 strands of 0.08 mm diameter, or equivalent. As shown in Figure 62, the Primary Coil has a circular shape and consists of a single layer. Table 41 lists the dimensions of the Primary Coil.

Figure 62. Primary Coil of Power Transmitter design A18

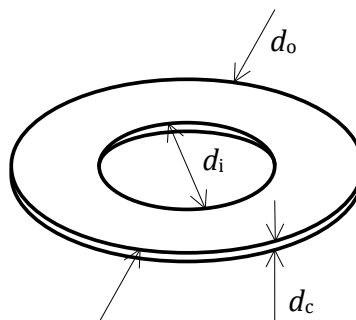

Table 41. Primary Coil parameters of Power Transmitter design A18

Parameter	Symbol	Value
Outer diameter	d_o	$39^{\pm 2}$ mm
Inner diameter	d_i	$12^{\pm 0.2}$ mm
Thickness	d_c	$1.5^{\pm 0.2}$ mm
Number of turns per layer	N	20
Number of layers	-	1

2.2.18.1.2 Shielding

As shown in Figure 63, Shielding protects the Base Station from the magnetic field that is generated in the Primary Coil. The Shielding should be Ni-Zn or Mn-Zn ferrite and should be at least 0.6 mm thick. The Shielding extends to at least 1 mm beyond the outer diameter of the Primary Coil, and is placed below the Primary Coil at a distance of at most $d_s = 0.5$ mm.

Figure 63. Primary Coil assembly of Power Transmitter design A18

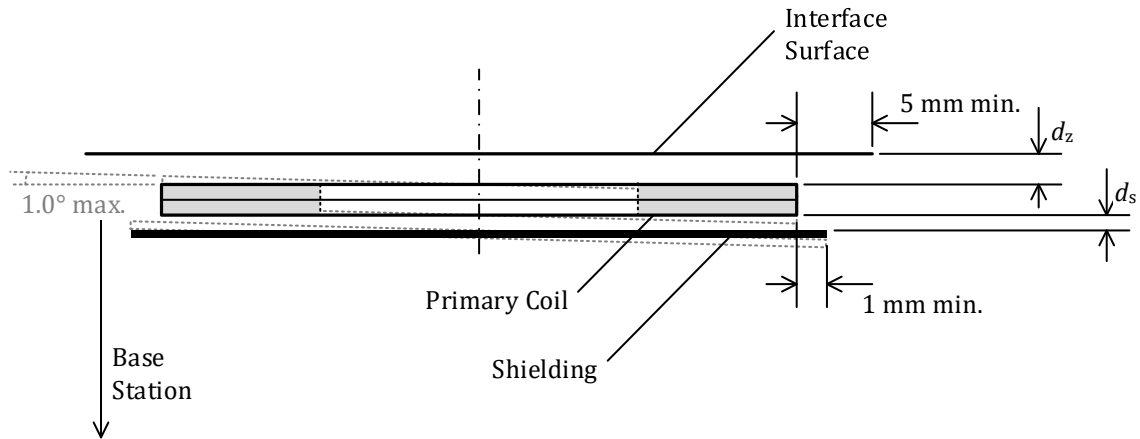

2.2.18.1.3 Interface Surface

As shown in Figure 63, the distance from the Primary Coil to the Interface Surface of the Base Station is $d_z = 2.0^{\pm 1.5}$ mm, across the top face of the Primary Coil. In addition, the Interface Surface of the Base Station extends at least 5mm beyond the outer diameter of the Primary Coil.

2.2.18.1.4 Alignment aid

The alignment aid consists of a visual, audible or tactile indication, which helps a user to guide a Power Receiver into the Active Area of the Interface Surface by giving directional or distance feedback.

2.2.18.2 Electrical details

As shown in Figure 64, Power Transmitter design A18 uses a full-bridge inverter to drive the Primary Coil and a series capacitance. At an Operating Frequency range between 105 kHz and 140 kHz, the assembly of Primary Coil and Shielding has a self inductance $L_p = 13.6^{\pm 10\%} \mu\text{H}$. The value of the series capacitance is $C_p = 180^{\pm 5\%} \text{nF}$.

NOTE Near resonance, the voltage developed across the series capacitance can reach levels up to 100 V pk-pk.

Power Transmitter design A18 uses the input voltage to the full-bridge inverter to control the amount of power that is transferred. For this purpose, the input voltage range is 3...12 V, where a lower input voltage results in the transfer of a lower amount of power. In order to achieve a sufficiently accurate adjustment of the power that is transferred, a type A18 Power Transmitter shall be able to control the input voltage with a resolution of 50 mV or better.

When a type A18 Power Transmitter first applies a Power Signal (Digital Ping; see *Parts 1 and 2: Interface Definitions*), it shall use an initial input voltage of 6.5 V. It is recommended that the Power Transmitter uses an Operating Frequency of 140 kHz when first applying the Power Signal. If the Power Transmitter does not receive a Signal Strength Packet from the Power Receiver, the Power Transmitter shall remove the Power Signal as defined in *Parts 1 and 2: Interface Definitions*. The Power Transmitter may reapply the Power Signal multiple times at other—consecutively lower—Operating Frequencies within the range specified above, until the Power Transmitter receives a Signal Strength Packet containing an appropriate Signal Strength Value.

Figure 64. Electrical diagram (outline) of Power Transmitter design A18

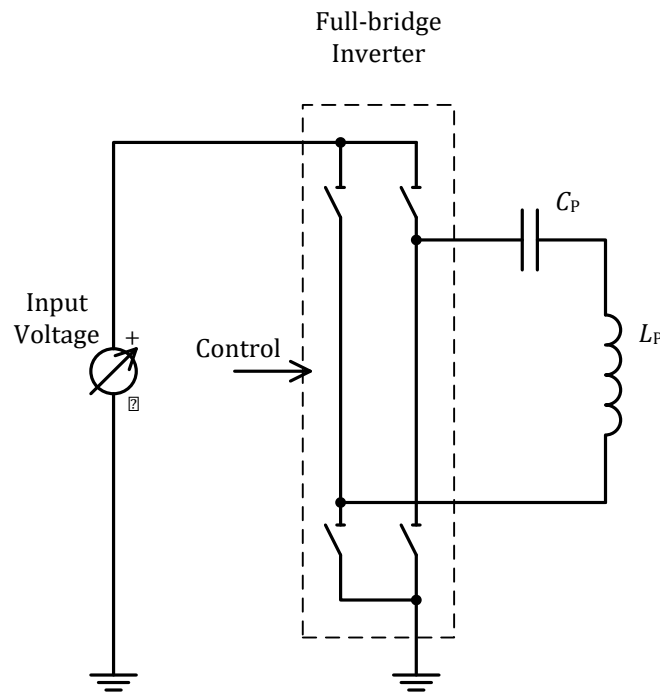

Control of the power transfer shall proceed using the PID algorithm, which is defined in *Parts 1 and 2: Interface Definitions*. The controlled variable $v^{(i)}$ introduced in the definition of that algorithm represents the input voltage to the full-bridge inverter. In order to guarantee sufficiently accurate power control, a type A18 Power Transmitter shall determine the amplitude of the Primary Cell voltage—which is equal to the Primary Coil voltage—with a resolution of 5 mV or better. Finally, Table 42 provides the values of several parameters, which are used in the PID algorithm.

Table 42. PID parameters for voltage control

Parameter	Symbol	Value	Unit
Proportional gain	K_p	1	mA^{-1}
Integral gain	K_i	0	$\text{mA}^{-1}\text{ms}^{-1}$
Derivative gain	K_d	0	mA^{-1}ms
Integral term limit	M_i	N.A.	N.A.
PID output limit	M_{PID}	1,500	N.A.
Scaling factor	S_v	-0.5	mV

2.2.19 Power Transmitter design A19

Figure 65 illustrates the functional block diagram of this design, which consists of two major functional units, namely a Power Conversion Unit and a Communications and Control Unit.

Figure 65. Functional block diagram of Power Transmitter design A19

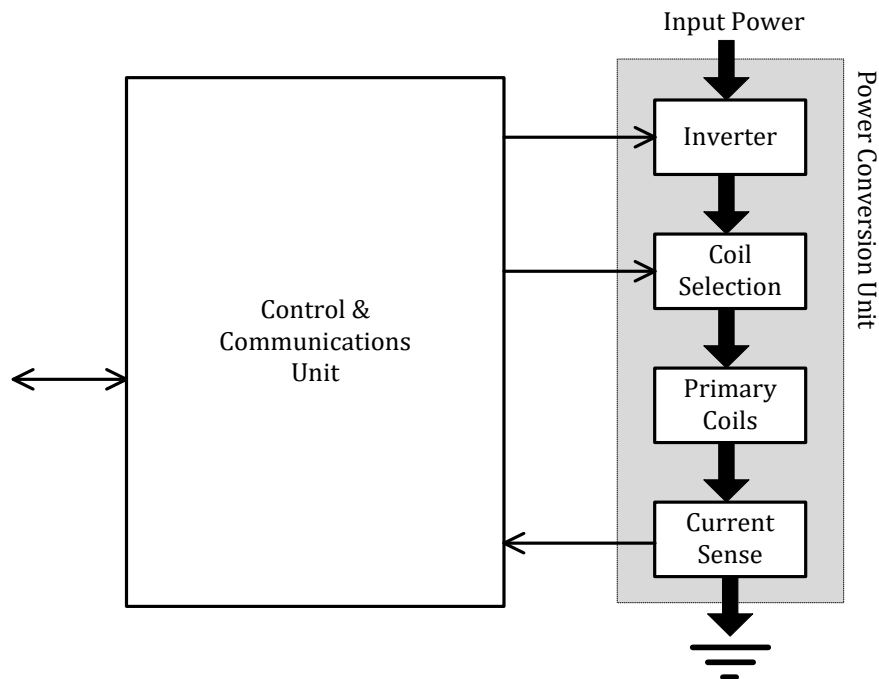

The Power Conversion Unit on the right-hand side of Figure 65 comprises the analog parts of the design. The inverter converts the DC input to an AC waveform that drives a resonant circuit, which consists of the selected Primary Coil plus a series capacitor. The selected Primary Coil is one from two partially overlapping Primary Coils, as appropriate for the position of the Power Receiver relative to the Primary Coils. Selection of the Primary Coil proceeds by the Power Transmitter attempting to establish communication with a Power Receiver using any of the Primary Coils. Finally, the current sense monitors the Primary Coil current.

The Communications and Control Unit on the left-hand side of Figure 65 comprises the digital logic part of the design. This unit receives and decodes messages from the Power Receiver, configures the Coil Selection block to connect the appropriate Primary Coil, executes the relevant power control algorithms and protocols, and drives the frequency of the AC waveform to control the power transfer. The Communications and Control Unit also interfaces with other subsystems of the Base Station, e.g. for user interface purposes.

2.2.19.1 Mechanical details

Power Transmitter design A19 includes two Primary Coils as defined in Section 2.2.19.1.1, Shielding as defined in Section 2.2.19.1.2, and an Interface Surface as defined in Section 2.2.19.1.3.

2.2.19.1.1 Primary Coil

The Primary Coil is of the wire-wound type, and consists of no. 20 AWG (0.81 mm diameter) type 2 litz wire having 105 strands of no. 40 AWG (0.08 mm diameter), or equivalent. As shown in Figure 66, the Primary Coil has a rectangular shape and consists of a single layer. Table 43 lists the dimensions of the Primary Coil.

Figure 66. Primary Coil of Power Transmitter design A19

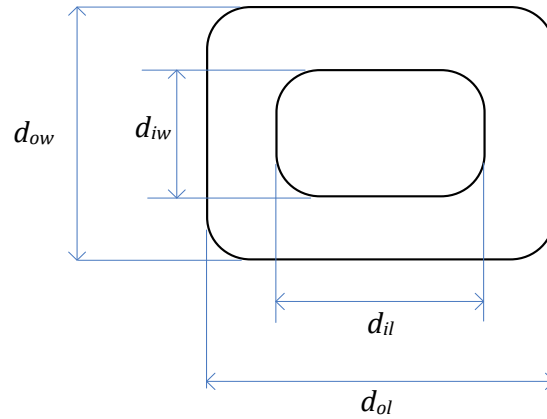
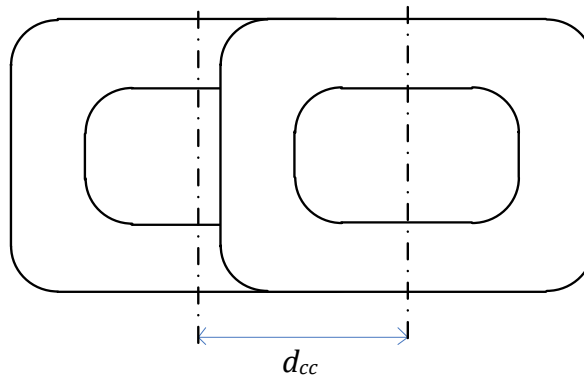

Table 43. Primary Coil parameters of Power Transmitter design A19

Parameter	Symbol	Value
Outer length	d_{ol}	$51.5^{\pm 0.5}$ mm
Inner length	d_{il}	$29.5^{\pm 0.5}$ mm
Outer width	d_{ow}	$43.3^{\pm 0.5}$ mm
Inner width	d_{iw}	$21.3^{\pm 0.5}$ mm
Thickness	d_c	$1.1^{\pm 0.5}$ mm
Number of turns per layer	N	12 turns
Number of layers	-	1

Power Transmitter design A19 contains two overlapping Primary Coils, with coinciding long axes. The distance between the Primary Coil centers is $d_{cc} = 27^{\pm 4}$ mm. See Figure 67.

Figure 67. Primary Coils of Power Transmitter design A19



2.2.19.1.2 Shielding

As shown in Figure 68, Shielding protects the Base Station from the magnetic field that is generated in the Primary Coil. The Shielding should be Ni-Zn or Mn-Zn ferrite and should be at least 0.5 mm thick. The Shielding extends to at least the outer dimensions of the Primary Coils, and is placed below the Primary Coil at a distance of at most $d_s = 1.0$ mm.

Figure 68. Primary Coil assembly of Power Transmitter design A19

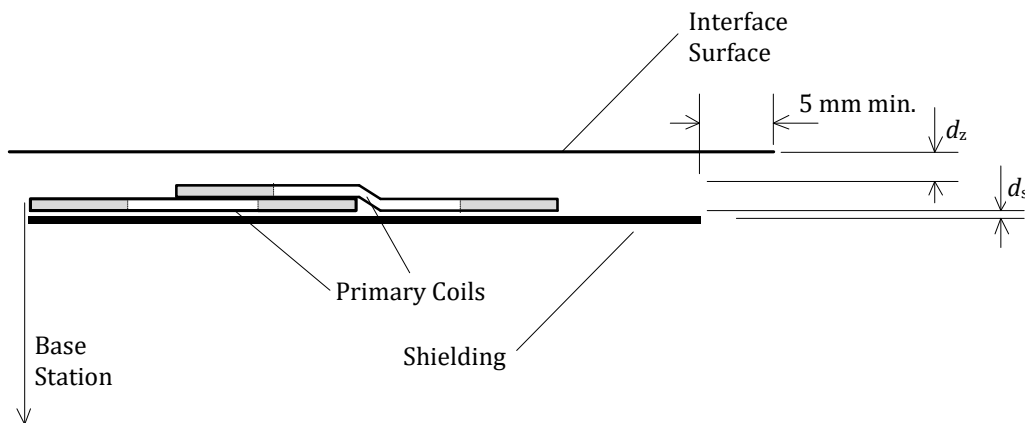

2.2.19.1.3 Interface Surface

As shown in Figure 68, the distance from the Primary Coil to the Interface Surface of the Base Station is $d_z = 2^{+0.5}_{-0.25}$ mm, across the top face of the Primary Coil. In addition, the Interface Surface of the Base Station extends at least 5 mm beyond the outer dimensions of the Primary Coils.

2.2.19.1.4 Inter coil separation

If the Base Station contains multiple type A19 Power Transmitters, the Primary Coils of any pair of those Power Transmitters shall have a center-to-center distance of at least $49.2^{\pm 4}$ mm.

2.2.19.2 Electrical details

As shown in Figure 69, Power Transmitter design A19 uses a half-bridge inverter to drive an individual Primary Coil and a series capacitance. Within the Operating Frequency range specified below, the assembly of Primary Coils and Shielding has a self inductance $L_p = 12.2^{\pm 10\%}$ μ H for coils closest to the Interface Surface and inductance $L_p = 12.5^{\pm 10\%}$ μ H for coils furthest from the Interface Surface. The value of the series capacitance is $C_p = 0.138^{\pm 5\%}$ μ F for coils closest to the Interface Surface and $C_p = 0.136^{\pm 5\%}$ μ F for coils furthest from the Interface Surface. The input voltage to the half-bridge inverter is $12^{\pm 5\%}$ V.

NOTE Near resonance, the voltage developed across the series capacitance can reach levels exceeding 100 V pk-pk.

Power Transmitter design A19 uses the Operating Frequency and duty cycle of the Power Signal in order to control the amount of power that is transferred. For this purpose, the Operating Frequency range of the half-bridge inverter is $f_{op} = 115 \dots 205$ kHz with a duty cycle of 50%; and its duty cycle range is 10...50% at an Operating Frequency of 205 kHz. A higher Operating Frequency or lower duty cycle result in the transfer of a lower amount of power. In order to achieve a sufficiently accurate adjustment of the amount of power that is transferred, a type A6 Power Transmitter shall control the Operating Frequency with a resolution of

- $0.01 \times f_{op} - 0.7$ kHz, for f_{op} in the 115...175 kHz range;
- $0.015 \times f_{op} - 1.58$ kHz, for f_{op} in the 175...205 kHz range;

or better. In addition, a type A19 Power Transmitter shall control the duty cycle of the Power Signal with a resolution of 0.1% or better.

When a type A19 Power Transmitter first applies a Power Signal (Digital Ping; see *Parts 1 and 2: Interface Definitions*), it shall use an initial Operating Frequency of 175 kHz (and a duty cycle of 50%).

Control of the power transfer shall proceed using the PID algorithm, which is defined in *Parts 1 and 2: Interface Definitions*. The controlled variable $v^{(i)}$ introduced in the definition of that algorithm represents the Operating Frequency or the duty cycle. In order to guarantee sufficiently accurate power control, a type A19 Power Transmitter shall determine the amplitude of the Primary Cell current—which is equal to the Primary Coil current—with a resolution of 7 mA or better. Finally, Table 44, Table 45, and Table 46 provide the values of several parameters, which are used in the PID algorithm.

Figure 69. Electrical diagram (outline) of Power Transmitter design A19

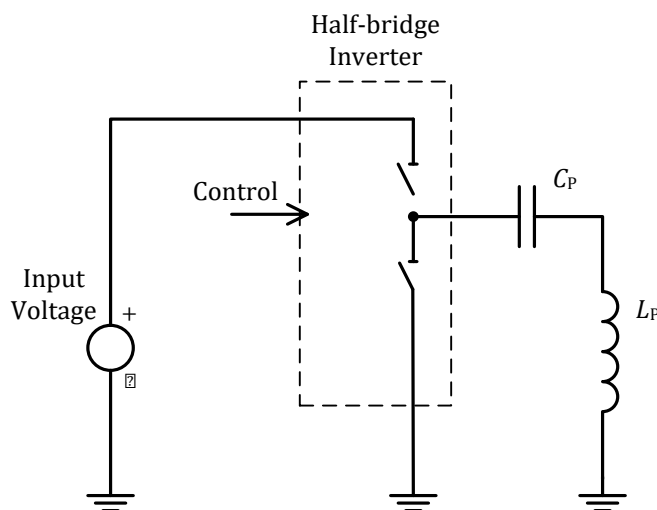

Table 44. PID parameters for Operating Frequency control

Parameter	Symbol	Value	Unit
Proportional gain	K_p	10	mA^{-1}
Integral gain	K_i	0.05	$\text{mA}^{-1}\text{ms}^{-1}$
Derivative gain	K_d	0	mA^{-1}ms
Integral term limit	M_I	3,000	N.A.
PID output limit	M_{PID}	20,000	N.A.

Table 45. Operating Frequency dependent scaling factor

Frequency Range [kHz]	Scaling Factor S_v [Hz]
115...140	1.5
140...160	2
160...180	3
180...205	5

Table 46. PID parameters for duty cycle control

Parameter	Symbol	Value	Unit
Proportional gain	K_p	10	mA^{-1}
Integral gain	K_i	0.05	$\text{mA}^{-1}\text{ms}^{-1}$
Derivative gain	K_d	0	mA^{-1}ms
Integral term limit	M_i	3,000	N.A.
PID output limit	M_{PID}	20,000	N.A.
Scaling factor	S_v	-0.01	%

2.2.20 Power Transmitter design A20

Figure 70 illustrates the functional block diagram of Power Transmitter design A20, which consists of two major functional units, namely a Power Conversion Unit and a Communications and Control Unit.

Figure 70. Functional block diagram of Power Transmitter design A20

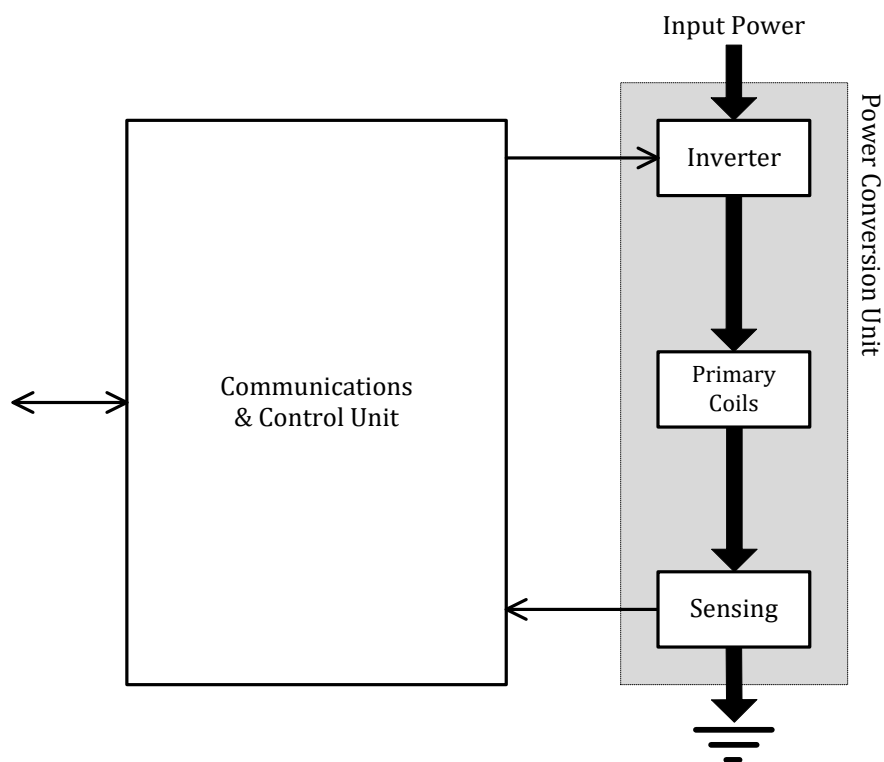

The Power Conversion Unit on the right-hand side of Figure 70 comprises the analog parts of the design. The inverter converts the DC input to an AC waveform that drives a resonant circuit, which consists of the Primary Coil plus a series capacitor. Finally, the voltage and current sense monitors the Primary Coil voltage and current.

The Communications and Control Unit on the left-hand side of Figure 70 comprises the digital logic part of the design. The unit receives and decodes messages from the Power Receiver, executes the relevant power control algorithms and protocols, and drives the input power and frequency of the AC waveform to control the power transfer. The Communications and Control Unit also interfaces with other subsystems of the Base Station, e.g. for user interface purposes.

2.2.20.1 Mechanical details

Power Transmitter design A20 includes one Primary Coil as defined in Section 2.2.20.1.1, Shielding as defined in Section 2.2.20.1.2, and an Interface Surface as defined in Section 2.2.20.1.3.

2.2.20.1.1 Primary Coil

The Primary Coil is of the wire-wound type, and consists of litz wire having 115 strands of 0.08 mm diameter, or equivalent. As shown in Figure 71, a Primary Coil has a racetrack-like shape and consists of a single layer. Table 47 lists the dimensions of a Primary Coil.

Figure 71. Primary Coil of Power Transmitter design A20

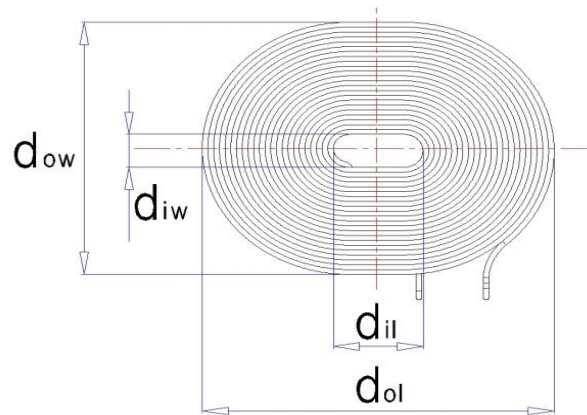

Table 47. Primary Coil parameters of Power Transmitter design A20

Parameter	Symbol	Value
Outer length	d_{ol}	$65.5^{\pm 0.5}$ mm
Inner length	d_{il}	$16.5^{\pm 0.5}$ mm
Outer width	d_{ow}	$57.1^{\pm 0.5}$ mm
Inner width	d_{iw}	$4.5^{\pm 0.5}$ mm
Thickness	d_c	$1.3^{\pm 0.15}$ mm
Number of turns per layer	N	22
Number of layers	–	1

2.2.20.1.2 Shielding

As shown in Figure 72, Shielding protects the Base Station from the magnetic field that is generated in the Primary Coil. The Shielding should be Ni-Zn or Mn-Zn ferrite and should be at least 2.0 mm thick.

The top face of the Shielding block is aligned with the top face of the Primary Coil, such that the Shielding surrounds the Primary Coil on all sides except for the top face. In addition, the Shielding extends to at least 2.5 mm beyond the outer edge of the Primary Coil.

Figure 72. Primary Coil assembly of Power Transmitter design A20

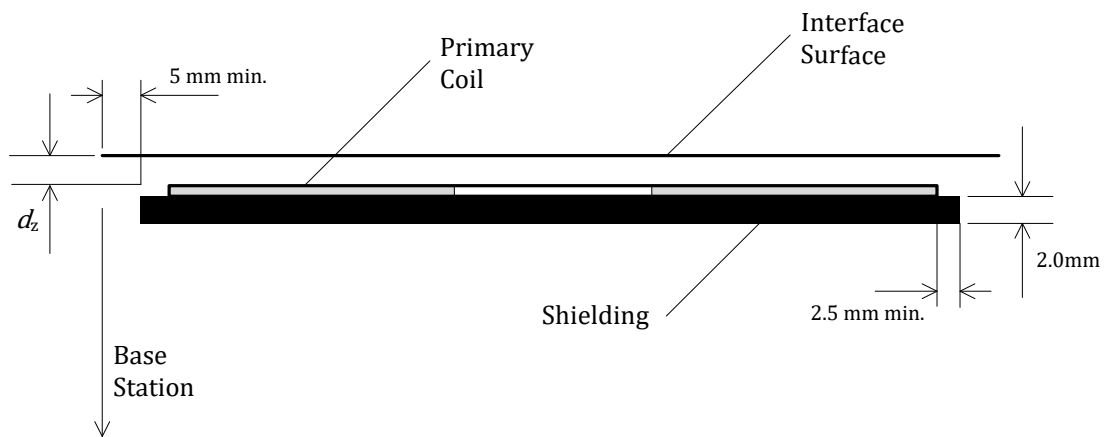

2.2.20.1.3 Interface Surface

As shown in Figure 72, the distance from the Primary Coil to the Interface Surface of the Base Station is $d_z = 3.0^{\pm 0.5}$ mm, across the top face of the Primary Coil. In addition, the Interface Surface of the Base Station extends at least 5 mm beyond the outer diameter of the Primary Coil.

2.2.20.1.4 Separation between multiple Power transmitters

If the Base Station contains multiple type A20 Power Transmitters, the Primary Coils of any pair of those Power Transmitters shall have a center-to-center distance of at least $65.0^{\pm 0.5}$ mm.

2.2.20.2 Electrical details

As shown in Figure 73, Power Transmitter design A20 uses a full-bridge inverter to drive the Primary Coil and a series capacitance. Within the Operating Frequency range Specified below, the assembly of Primary Coil and Shielding has a self inductance $L_p = 24^{\pm 10\%}$ μH . The value of the series capacitance is $C_p = 148^{\pm 5\%}$ nF.

NOTE Near resonance, the voltage developed across the series capacitance can reach levels up to 100 V pk-pk.

Power Transmitter design A20 uses the input voltage to the full-bridge inverter to control the amount of power transferred. For this purpose, the input voltage has a range $2.5^{\pm 0.5} \dots 11.5^{\pm 0.5}$ V, with a resolution of 10mV or better; a higher input voltage results in more power transferred. The Operating Frequency range is $f_{op} = 87 \dots 110$ kHz.

When a type A20 Power Transmitter first applies a Power Signal (Digital Ping; see *Parts 1 and 2: Interface Definitions*), the Power Transmitter shall use an Operating Frequency of 98 kHz, and an input voltage of $5.5^{\pm 2.0}$ V. If the Power Transmitter does not receive a Signal Strength Packet from the Power Receiver, the Power Transmitter shall remove the Power Signal as defined in *Parts 1 and 2: Interface Definitions*. The Power Transmitter may reapply the Power Signal multiple times at consecutively lower-Operating Frequencies within the range specified above, until the Power Transmitter receives a Signal Strength Packet containing an appropriate Signal Strength Value.

Figure 73. Electrical diagram (outline) of Power Transmitter design A20

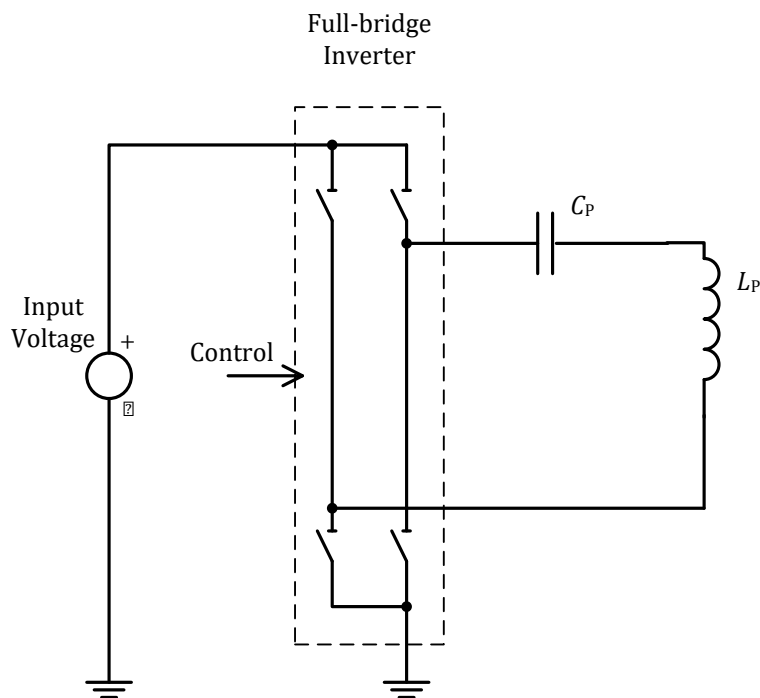

Control of the power transfer shall proceed using the PID algorithm, which is defined in *Parts 1 and 2: Interface Definitions*. The controlled variable $v^{(i)}$ introduced in the definition of that algorithm represents Operating Frequency as well as the input voltage to the full-bridge inverter. It is recommended that control of the power occurs primarily by means of adjustments to the Operating Frequency, and that voltage adjustments are made only at the boundaries of the Operating Frequency range. In order to guarantee sufficiently accurate power control, a type A20 Power Transmitter shall determine the amplitude of the Primary Coil current with a resolution of 5 mA or better. Finally, Table 48 and Table 49 provide the values of several parameters, which are used in the PID algorithm.

Table 48. PID parameters for Operating Frequency control

Parameter	Symbol	Value	Unit
Proportional gain	K_p	1	mA^{-1}
Integral gain	K_i	0	$\text{mA}^{-1}\text{ms}^{-1}$
Derivative gain	K_d	0	mA^{-1}ms
Integral term limit	M_I	N.A.	N.A.
PID output limit	M_{PID}	20,000	N.A.
Scaling factor	S_v	1.0	Hz

Table 49. PID parameters for voltage control

Parameter	Symbol	Value	Unit
Proportional gain	K_p	1	mA^{-1}
Integral gain	K_i	0	$\text{mA}^{-1}\text{ms}^{-1}$
Derivative gain	K_d	0	mA^{-1}ms
Integral term limit	M_I	N.A.	N.A.
PID output limit	M_{PID}	1,500	N.A.
Scaling factor	S_v	-0.5	mV

2.2.21 Power Transmitter design A21

Figure 74 illustrates the functional block diagram of this Power Transmitter design A21, which consists of two major functional units, namely a Power Conversion Unit and a Communications and Control Unit.

Figure 74. Functional block diagram of Power Transmitter design A21

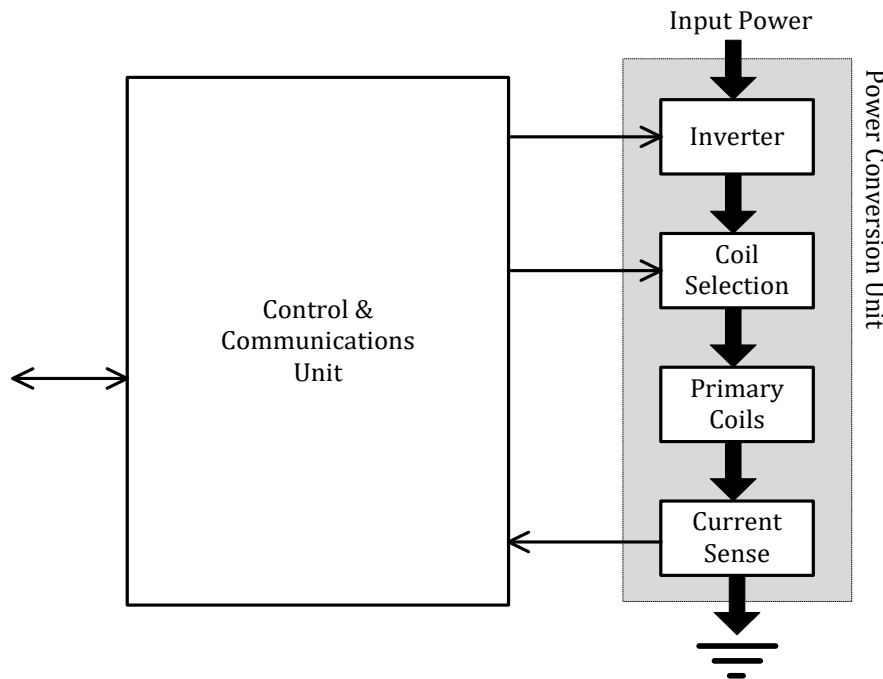

The Power Conversion Unit on the right-hand side of Figure 74 comprises the analog parts of the design. The inverter converts the DC input to an AC waveform that drives a resonant circuit, which consists of the selected Primary Coil plus a series capacitor. The selected Primary Coil is one from at least three partially overlapping Primary Coils, as appropriate for the position of the Power Receiver relative to the Primary Coils. Selection of the Primary Coil proceeds by the Power Transmitter attempting to establish communication with a Power Receiver using any of the Primary Coils. Finally, the current sense monitors the Primary Coil current.

The Communications and Control Unit on the left-hand side of Figure 74 comprises the digital logic part of the design. This unit receives and decodes messages from the Power Receiver, configures the Coil Selection block to connect the appropriate Primary Coil, executes the relevant power control algorithms and protocols, and drives the frequency of the AC waveform to control the power transfer. The Communications and Control Unit also interfaces with other subsystems of the Base Station, e.g. for user interface purposes.

2.2.21.1 Mechanical details

Power Transmitter design A21 includes one or more Primary Coils as defined in Section 2.2.21.1.1, Shielding as defined in Section 2.2.21.1.2, an Interface Surface as defined in Section 2.2.21.1.3.

2.2.21.1.1 Primary Coil

The Primary Coil consists of at least one PCB coil. Figure 75 shows a view of a single Primary Coil. Table 50 lists the dimensions of the Primary Coil.

Figure 75. Primary Coil of Power Transmitter design A21

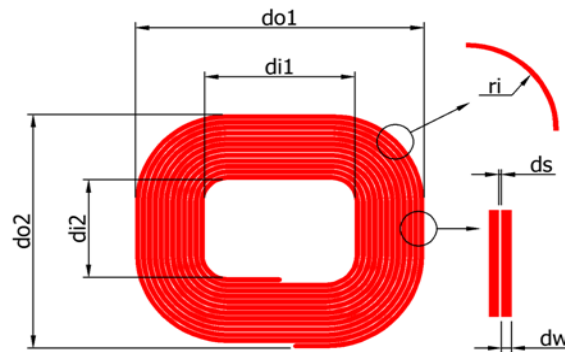

Table 50. Primary Coil parameters of Power Transmitter design A21

Parameter	Symbol	Value
Outer length	d_{o1}	$53.4^{\pm 0.7}$ mm
Inner length	d_{i1}	$27.5^{\pm 0.7}$ mm
Outer width	d_{o2}	$45.8^{\pm 0.7}$ mm
Inner width	d_{i2}	$19.5^{\pm 0.75}$ mm
4-layer PCB		
Track width	d_w	$0.82^{\pm 0.2}$ mm
Track width plus spacing	$d_w + d_s$	$1.08^{\pm 0.2}$ mm
Corner rounding*	r_i	$16.7^{\pm 1.0}$ mm
Number of turns	N	12
5...8-layer PCB		
Track width	d_w	$0.55^{\pm 0.15}$ mm
Track width plus spacing	$d_w + d_s$	$1.1^{\pm 0.15}$ mm
Corner rounding*	r_i	$13.1^{\pm 1.31}$ mm
Number of turns	N	12 ± 0.25

* Outermost winding only

Power Transmitter design A21 contains at least one Primary Coil. Odd numbered coils are placed alongside each other with a displacement of d_{h2} between their centers. Even numbered coils are placed orthogonal to the odd numbered coils with a displacement of d_{h1} mm between their centers. See Figure 76.

Figure 76. Primary Coils of Power Transmitter design A21

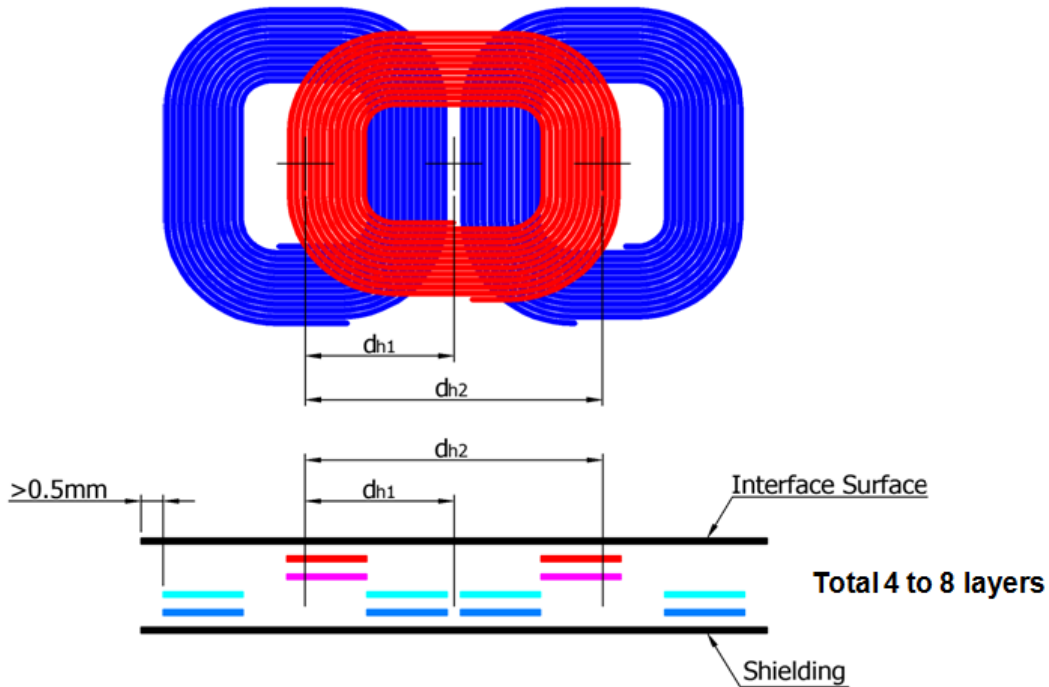

Figure 77. Primary Coils of Power Transmitter design A21

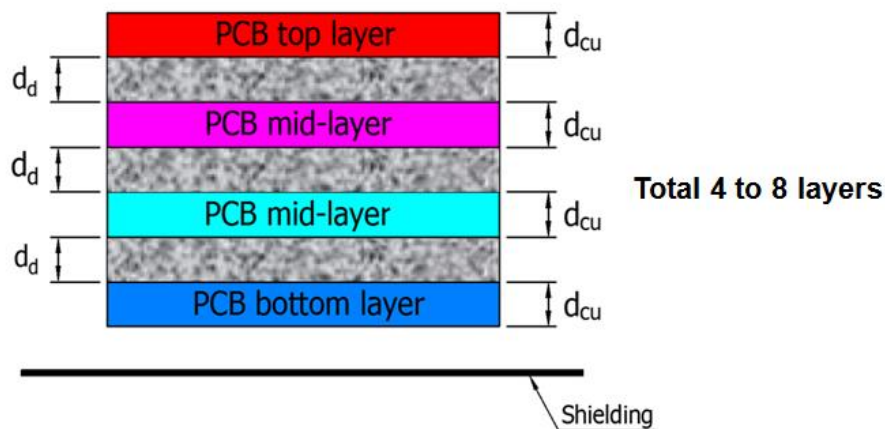

Table 51. Primary Coil parameters of Power Transmitter design A21

Parameter	Symbol	Value
4-layer PCB		
Center-to-center distance	d_{h1}	$23.8^{±1.0}$ mm
Center-to-center distance	d_{h2}	$47.52^{±2.0}$ mm
PCB copper thickness	d_{Cu}	$0.105^{±0.015}$ mm
Dielectric thickness	d_d	$0.375^{±0.063}$ mm
5...8-layer PCB		
Center-to-center distance	d_{h1}	$23.76^{±1.5}$ mm
Center-to-center distance	d_{h2}	$47.52^{±3}$ mm
PCB copper thickness	d_{Cu}	$0.105^{±0.0161}$ mm
Dielectric thickness	d_d	$0.125^{±0.0254}$ mm

2.2.21.1.2 Shielding

As shown in Figure 78, Shielding protects the Base Station from the magnetic field that is generated in the Primary Coil. The Shielding should be Ni-Zn or Mn-Zn ferrite and should be at least 0.8 mm thick. The Shielding extends to at least the outer dimensions of the Primary Coils, and is placed below the Primary Coil at a distance of at most $d_s = 1.0$ mm.

Figure 78. Primary Coil assembly of Power Transmitter design A21

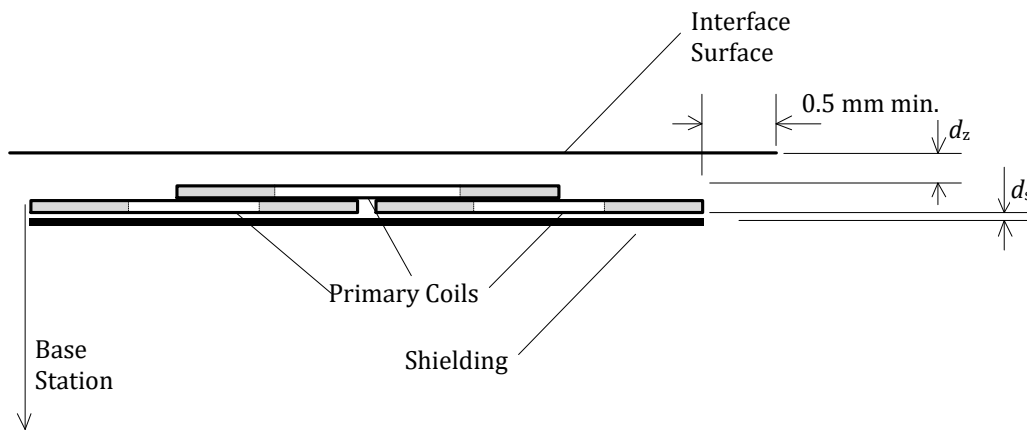

2.2.21.1.3 Interface Surface

As shown in Figure 78, the distance from the Primary Coil to the Interface Surface of the Base Station is $d_z = 2.75^{±1}$ mm, across the top face of the Primary Coil. In addition, the Interface Surface of the Base Station extends at least 0.5 mm beyond the outer dimensions of the Primary Coils.

2.2.21.1.4 Inter coil separation

If the Base Station contains multiple type A21 Power Transmitters, the Primary Coils of any pair of those Power Transmitters shall have a center-to-center distance of at least $49.2^{\pm 4}$ mm.

2.2.21.2 Electrical details

As shown in Figure 79, Power Transmitter design A21 uses a half-bridge inverter to drive an individual Primary Coil and a series capacitance. Within the Operating Frequency range specified below, the assembly of Primary Coils and Shielding has a self inductance $L_p = 11.5^{\pm 10\%}$ μH for coils closest to the Interface Surface and inductance $L_p = 12.5^{\pm 10\%}$ μH for coils furthest from the Interface Surface. The value of the series capacitance is $C_p = 0.147^{\pm 5\%}$ μF for coils closest to the Interface Surface and $C_p = 0.136^{\pm 5\%}$ μF for coils furthest from the Interface Surface. The input voltage to the half-bridge inverter is $12^{\pm 5\%}$ V.

NOTE Near resonance, the voltage developed across the series capacitance can reach levels exceeding 100 V pk-pk.

Power Transmitter design A21 uses the Operating Frequency and duty cycle of the Power Signal in order to control the amount of power that is transferred. For this purpose, the Operating Frequency range of the half-bridge inverter is $f_{op} = 115 \dots 205$ kHz with a duty cycle of 50%; and its duty cycle range is 10...50% at an Operating Frequency of 205 kHz. A higher Operating Frequency or lower duty cycle result in the transfer of a lower amount of power. In order to achieve a sufficiently accurate adjustment of the amount of power that is transferred, a type A21 Power Transmitter shall control the Operating Frequency with a resolution of

- $0.01 \times f_{op} - 0.7$ kHz, for f_{op} in the 115...175 kHz range;
- $0.015 \times f_{op} - 1.58$ kHz, for f_{op} in the 175...205 kHz range;

or better. In addition, a type A21 Power Transmitter shall control the duty cycle of the Power Signal with a resolution of 0.1% or better.

When a type A21 Power Transmitter first applies a Power Signal (Digital Ping; see *Parts 1 and 2: Interface Definitions*), it shall use an initial Operating Frequency of 175 kHz (and a duty cycle of 50%).

Control of the power transfer shall proceed using the PID algorithm, which is defined in *Parts 1 and 2: Interface Definitions*. The controlled variable $v^{(i)}$ introduced in the definition of that algorithm represents the Operating Frequency or the duty cycle. In order to guarantee sufficiently accurate power control, a type A21 Power Transmitter shall determine the amplitude of the Primary Cell current—which is equal to the Primary Coil current—with a resolution of 7 mA or better. Finally, Table 52, Table 53, and Table 54 provide the values of several parameters, which are used in the PID algorithm.

Figure 79. Electrical diagram (outline) of Power Transmitter design A21

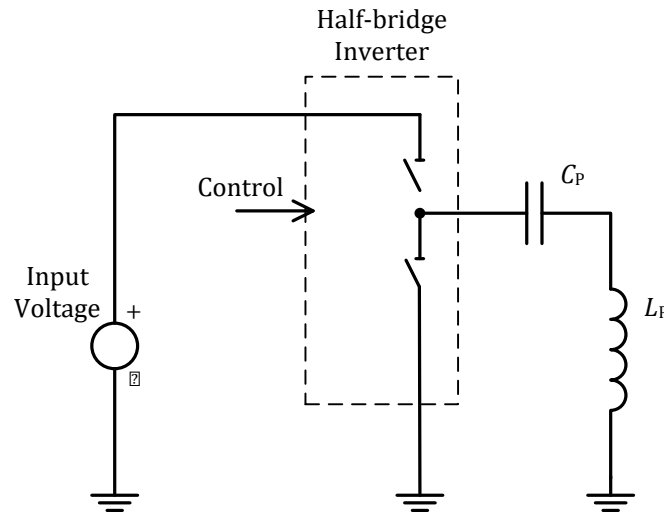

Table 52. PID parameters for Operating Frequency control

Parameter	Symbol	Value	Unit
Proportional gain	K_p	10	mA^{-1}
Integral gain	K_i	0.05	$\text{mA}^{-1}\text{ms}^{-1}$
Derivative gain	K_d	0	mA^{-1}ms
Integral term limit	M_I	3,000	N.A.
PID output limit	M_{PID}	20,000	N.A.

Table 53. Operating Frequency dependent scaling factor

Frequency Range [kHz]	Scaling Factor S_v [Hz]
115...140	1.5
140...160	2
160...180	3
180...205	5

Table 54. PID parameters for duty cycle control

Parameter	Symbol	Value	Unit
Proportional gain	K_p	10	mA^{-1}
Integral gain	K_i	0.05	$\text{mA}^{-1}\text{ms}^{-1}$
Derivative gain	K_d	0	mA^{-1}ms
Integral term limit	M_i	3,000	N.A.
PID output limit	M_{PID}	20,000	N.A.
Scaling factor	S_v	-0.01	%

2.2.22 Power Transmitter design A22

Figure 80 illustrates the functional block diagram of Power Transmitter design A22, which consists of two major functional units, namely a Power Conversion Unit and a Communications and Control Unit.

Figure 80. Functional block diagram of Power Transmitter design A22

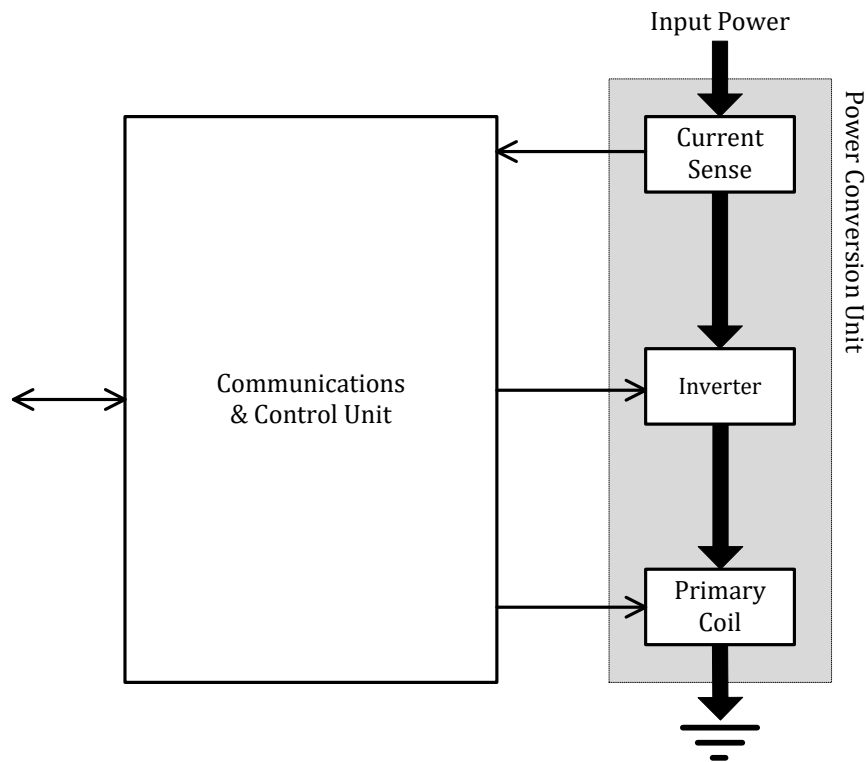

The Power Conversion Unit on the right-hand side of Figure 80 comprises the analog parts of the design. The voltage and current sense monitors the input voltage and current. The inverter converts the DC input to an AC waveform that drives a resonant circuit, which consists of the Primary Coil plus a series capacitor.

The Communications and Control Unit on the left-hand side of Figure 80 comprises the digital logic part of the design. The unit receives and decodes messages from the Power Receiver, executes the relevant power control algorithms and protocols, and drives the input power and frequency of the AC waveform to control the power transfer. The Communications and Control Unit also interfaces with other subsystems of the Base Station, e.g. for user interface purposes.

2.2.22.1 Mechanical details

Power Transmitter design A22 includes one Primary Coil as defined in Section 2.2.22.1.1, Shielding as defined in Section 2.2.22.1.2, and an Interface Surface as defined in Section 2.2.22.1.3.

2.2.22.1.1 Primary Coil

The Primary Coil is of the wire-wound type, and consists of litz wire having 115 strands of 0.08 mm diameter, or equivalent. As shown in Figure 81, a Primary Coil has a racetrack-like shape and consists of a single layer. Table 55 lists the dimensions of a Primary Coil.

Figure 81. Primary Coil of Power Transmitter design A22

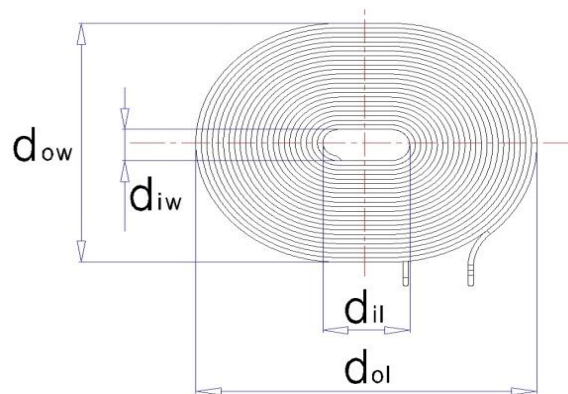

Table 55. Primary Coil parameters of Power Transmitter design A22

Parameter	Symbol	Value
Outer length	d_{ol}	$65.5^{\pm 0.5}$ mm
Inner length	d_{il}	$16.5^{\pm 0.5}$ mm
Outer width	d_{ow}	$57.1^{\pm 0.5}$ mm
Inner width	d_{iw}	$4.5^{\pm 0.5}$ mm
Thickness	d_c	$1.3^{\pm 0.15}$ mm
Number of turns per layer	N	22
Number of layers	-	1

2.2.22.1.2 Shielding

As shown in Figure 82, Shielding protects the Base Station from the magnetic field that is generated in the Primary Coil. The Shielding should be Ni-Zn or Mn-Zn ferrite and should be at least 2.0 mm thick. The Shielding may surround the Primary Coil on all sides except for the top face. In addition, the Shielding extends to at least 2.5 mm beyond the outer edge of the Primary Coil.

Figure 82. Primary Coil assembly of Power Transmitter design A22

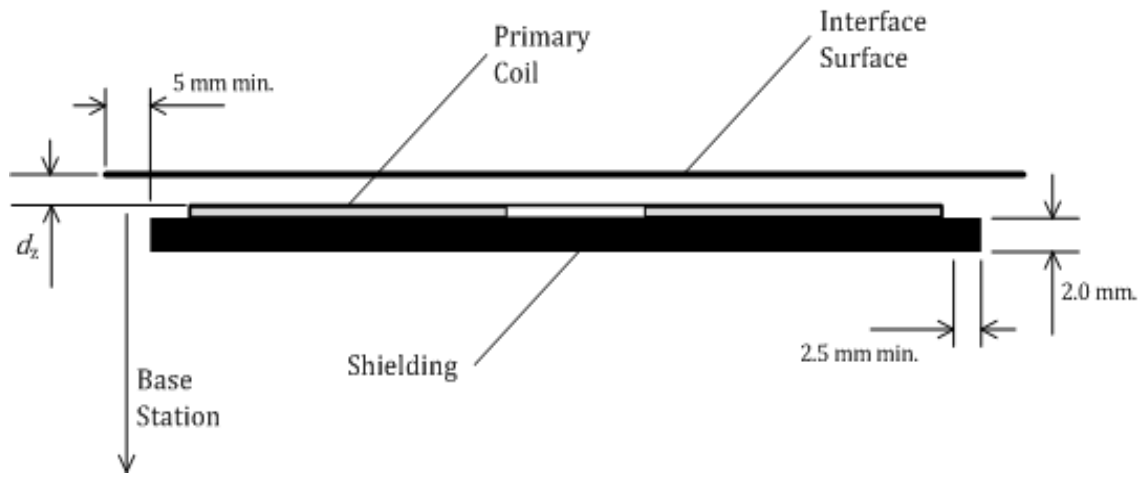

2.2.22.1.3 Interface Surface

As shown in Figure 82, the distance from the Primary Coil to the Interface Surface of the Base Station is $d_z = 2.5^{+1.0}$ mm, across the top face of the Primary Coil. In addition, the Interface Surface of the Base Station extends at least 5 mm beyond the outer diameter of the Primary Coil.

2.2.22.1.4 Separation between multiple Power transmitters

If the Base Station contains multiple type A22 Power Transmitters, the Primary Coils of any pair of those Power Transmitters shall have a center-to-center distance of at least 66 mm.

2.2.22.2 Electrical details

As shown in Figure 83, Power Transmitter design A22 uses a full-bridge inverter to drive the Primary Coil and a series capacitance. Within the Operating Frequency range Specified below, the assembly of Primary Coil and Shielding has a self inductance $L_p = 19.0^{\pm 10\%}$ μH . The value of the series capacitance is $C_p = 122^{\pm 10\%}$ nF.

NOTE Near resonance, the voltage developed across the series capacitance can reach levels up to 100 V pk-pk.

Power Transmitter design A22 uses the input voltage to the full-bridge inverter as well as its Operating Frequency and duty cycle to control the amount of power transferred. For this purpose, the input voltage range is 2 ... 12 V, with a resolution of 10 mV or better; the Operating Frequency range is 110...205 kHz; and the duty cycle range is 2 ... 50%.

When a type A22 Power Transmitter first applies a Power Signal (Digital Ping; see *Parts 1 and 2: Interface Definitions*), the Power Transmitter shall use an Operating Frequency of $125^{\pm 10}$ kHz, and an input voltage of 3.5 ... 7.5 V. If the Power Transmitter does not to receive a Signal Strength Packet from the Power Receiver, the Power Transmitter shall remove the Power Signal as defined in *Parts 1 and 2: Interface Definitions*. The Power Transmitter may re-apply the power signal multiple times at consecutively higher input voltage to the full-bridge inverter within the range specified above, until the Power Transmitter receives a Signal Strength Packet containing an appropriate Signal Strength Value.

Control of the power transfer shall proceed using the PID algorithm, which is defined in *Parts 1 and 2: Interface Definitions*. The controlled variable $v^{(i)}$ introduced in the definition of that algorithm represents the input voltage to the full-bridge inverter, Operating Frequency and duty cycle. It is recommended that control of the power occurs primarily by means of adjustments to the input voltage. In order to guarantee sufficiently accurate power control, a type A22 Power Transmitter shall determine the amplitude of the Primary Coil current with a resolution of 5 mA or better. Finally, Table 56, Table 57, and Table 58 provide the values of several parameters, which are used in the PID algorithm.

Figure 83. Electrical diagram (outline) of Power Transmitter design A22

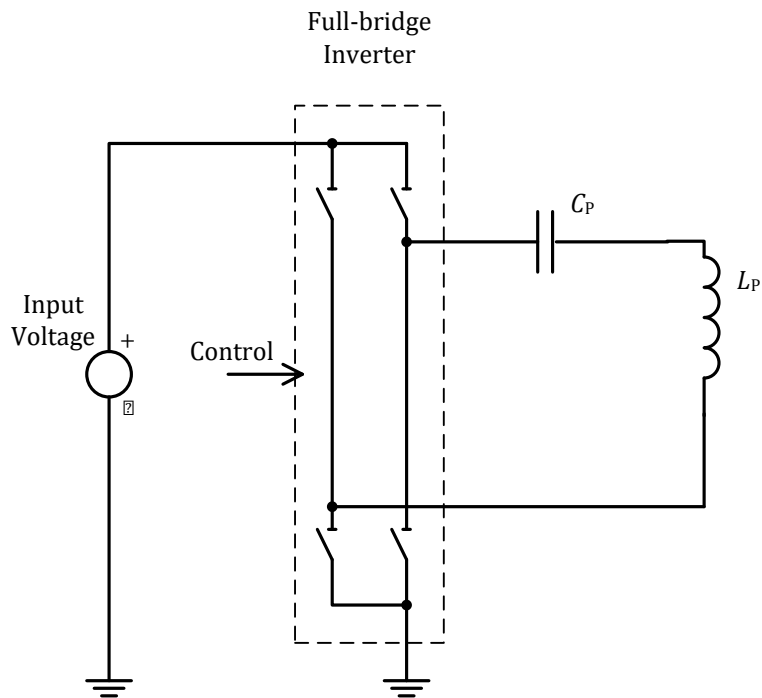

Table 56. PID parameters for voltage control

Parameter	Symbol	Value	Unit
Proportional gain	K_p	1	mA-1
Integral gain	K_i	0	mA-1ms-1
Derivative gain	K_d	0	mA-1ms
Integral term limit	M_I	N.A.	N.A.
PID output limit	M_{PID}	1,500	N.A.
Scaling factor	S_v	-0.5	mV

Table 57. PID parameters for Operating Frequency control

Parameter	Symbol	Value	Unit
Proportional gain	K_p	1	mA^{-1}
Integral gain	K_i	0	$\text{mA}^{-1}\text{ms}^{-1}$
Derivative gain	K_d	0	mA^{-1}ms
Integral term limit	M_I	N.A.	N.A.
PID output limit	M_{PID}	20,000	N.A.
Scaling factor	S_v	1.0	Hz

Table 58. PID parameters for duty control

Parameter	Symbol	Value	Unit
Proportional gain	K_p	1	mA^{-1}
Integral gain	K_i	0	$\text{mA}^{-1}\text{ms}^{-1}$
Derivative gain	K_d	0	mA^{-1}ms
Integral term limit	M_I	N.A.	N.A.
PID output limit	M_{PID}	20,000	N.A.
Scaling factor	S_v	-0.1	°

2.2.23 Power Transmitter design A23

Figure 84 illustrates the functional block diagram of Power Transmitter design A23, which consists of two major functional units, namely a Power Conversion Unit and a Communications and Control Unit.

Figure 84. Functional block diagram of Power Transmitter design A23

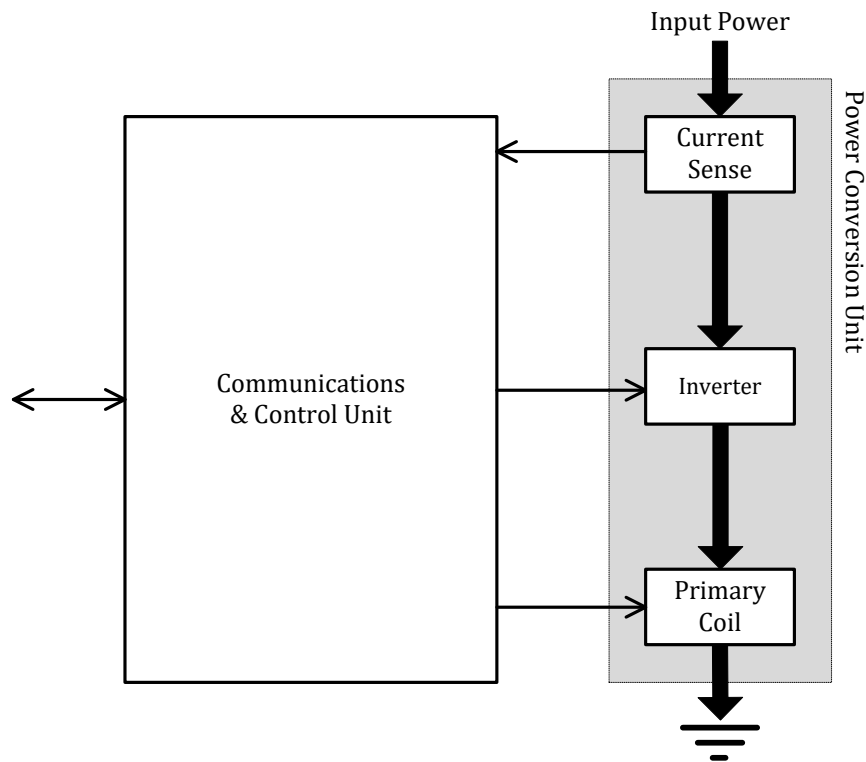

The Power Conversion Unit on the right-hand side of Figure 84 comprises the analog parts of the design. The voltage and current sense monitors the input voltage and current. The inverter converts the DC input to an AC waveform that drives a resonant circuit, which consists of the Primary Coil plus a series capacitor.

The Communications and Control Unit on the left-hand side of Figure 84 comprises the digital logic part of the design. The unit receives and decodes messages from the Power Receiver, executes the relevant power control algorithms and protocols, and drives the input power and frequency of the AC waveform to control the power transfer. The Communications and Control Unit also interfaces with other subsystems of the Base Station, e.g. for user interface purposes.

2.2.23.1 Mechanical details

Power Transmitter design A23 includes one Primary Coil as defined in Section 2.2.23.1.1, Shielding as defined in Section 2.2.23.1.2, and an Interface Surface as defined in Section 2.2.23.1.3.

2.2.23.1.1 Primary Coil

The Primary Coil is of the wire-wound type, and consists of litz wire having 115 strands of 0.08 mm diameter, or equivalent. As shown in Figure 85, a Primary Coil has a racetrack-like shape and consists of a single layer. Table 59 lists the dimensions of a Primary Coil.

Figure 85. Primary Coil of Power Transmitter design A23

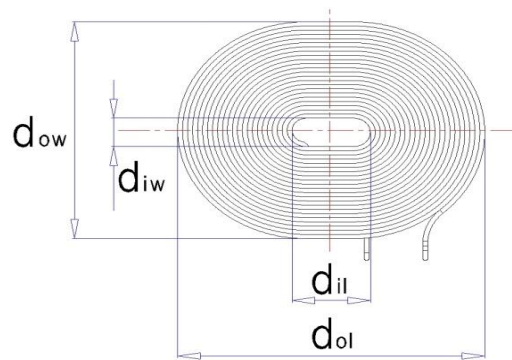

Table 59. Primary Coil parameters of Power Transmitter design A23

Parameter	Symbol	Value
Outer length	d_{ol}	$65.5^{\pm 0.5}$ mm
Inner length	d_{il}	$16.5^{\pm 0.5}$ mm
Outer width	d_{ow}	$57.1^{\pm 0.5}$ mm
Inner width	d_{iw}	$4.5^{\pm 0.5}$ mm
Thickness	d_c	$1.3^{\pm 0.15}$ mm
Number of turns per layer	N	22
Number of layers	-	1

2.2.23.1.2 Shielding

As shown in Figure 86, Shielding protects the Base Station from the magnetic field that is generated in the Primary Coil. The Shielding should be Ni-Zn or Mn-Zn ferrite and should be at least 2.0 mm thick. The Shielding may surround the Primary Coil on all sides except for the top face. In addition, the Shielding extends to at least 2.5 mm beyond the outer edge of the Primary Coil.

Figure 86. Primary Coil assembly of Power Transmitter design A23

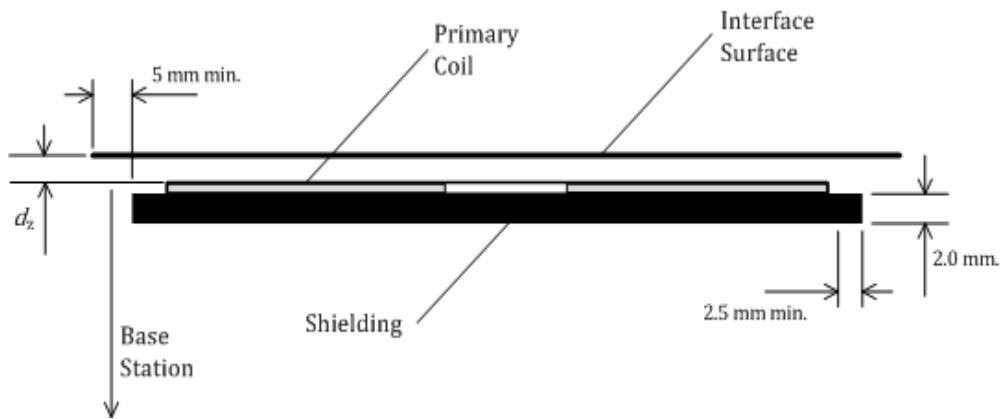

2.2.23.1.3 Interface Surface

As shown in Figure 86, the distance from the Primary Coil to the Interface Surface of the Base Station is $d_z = 2.5 \pm 1.0$ mm, across the top face of the Primary Coil. In addition, the Interface Surface of the Base Station extends at least 5 mm beyond the outer diameter of the Primary Coil.

2.2.23.1.4 Separation between multiple Power transmitters

If the Base Station contains multiple type A23 Power Transmitters, the Primary Coils of any pair of those Power Transmitters shall have a center-to-center distance of at least 66 mm.

2.2.23.2 Electrical details

As shown in Figure 87, Power Transmitter design A23 uses a full-bridge inverter to drive the Primary Coil and a series capacitance. Within the Operating Frequency range Specified below, the assembly of Primary Coil and Shielding has a self inductance $L_p = 19.0^{\pm 10\%}$ μH . The value of the series capacitance is $C_p = 168^{\pm 10\%}$ nF.

NOTE Near resonance, the voltage developed across the series capacitance can reach levels up to 100 V pk-pk.

Power Transmitter design A23 uses the input voltage to the full-bridge inverter as well as its Operating Frequency and duty cycle to control the amount of power transferred. For this purpose, the input voltage range is 2 ... 12 V, with a resolution of 10 mV or better; the Operating Frequency range is 101...115 kHz; and the duty cycle range is 2 ... 50%.

When a type A23 Power Transmitter first applies a Power Signal (Digital Ping; see *Parts 1 and 2: Interface Definitions*), the Power Transmitter shall use an Operating Frequency of $108^{\pm 5}$ kHz, and an input voltage of 3.5 ... 7.5 V. If the Power Transmitter does not receive a Signal Strength Packet from the Power Receiver, the Power Transmitter shall remove the Power Signal as defined in *Parts 1 and 2: Interface Definitions*. The Power Transmitter may re-apply the power signal multiple times at consecutively higher input voltage to the full-bridge inverter within the range specified above, until the Power Transmitter receives a Signal Strength Packet containing an appropriate Signal Strength Value.

Control of the power transfer shall proceed using the PID algorithm, which is defined in *Parts 1 and 2: Interface Definitions*. The controlled variable $v^{(i)}$ introduced in the definition of that algorithm represents the input voltage to the full-bridge inverter, Operating Frequency and duty cycle. It is recommended that control of the power occurs primarily by means of adjustments to the input voltage. In order to guarantee sufficiently accurate power control, a type A23 Power Transmitter shall determine the amplitude of the Primary Coil current with a resolution of 5 mA or better. Finally, Table 60, Table 61, and Table 62 provide the values of several parameters, which are used in the PID algorithm.

Figure 87. Electrical diagram (outline) of Power Transmitter design A23

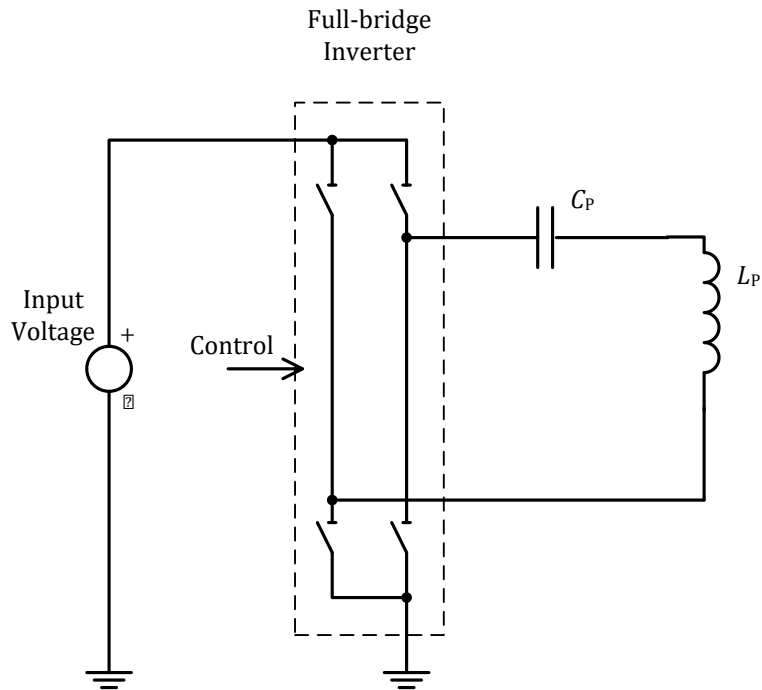

Table 60. PID parameters for voltage control

Parameter	Symbol	Value	Unit
Proportional gain	K_p	1	mA-1
Integral gain	K_i	0	mA-1ms-1
Derivative gain	K_d	0	mA-1ms
Integral term limit	M_I	N.A.	N.A.
PID output limit	M_{PID}	1,500	N.A.
Scaling factor	S_v	-0.5	mV

Table 61. PID parameters for Operating Frequency control

Parameter	Symbol	Value	Unit
Proportional gain	K_p	1	mA^{-1}
Integral gain	K_i	0	$\text{mA}^{-1}\text{ms}^{-1}$
Derivative gain	K_d	0	mA^{-1}ms
Integral term limit	M_I	N.A.	N.A.
PID output limit	M_{PID}	20,000	N.A.
Scaling factor	S_v	1.0	Hz

Table 62. PID parameters for duty control

Parameter	Symbol	Value	Unit
Proportional gain	K_p	1	mA^{-1}
Integral gain	K_i	0	$\text{mA}^{-1}\text{ms}^{-1}$
Derivative gain	K_d	0	mA^{-1}ms
Integral term limit	M_I	N.A.	N.A.
PID output limit	M_{PID}	20,000	N.A.
Scaling factor	S_v	-0.1	°

2.2.24 Power Transmitter design A24

Figure 88 illustrates the functional block diagram of Power Transmitter design A24, which consists of two major functional units, namely a Power Conversion Unit and a Communications and Control Unit.

Figure 88. Functional block diagram of Power Transmitter design A24

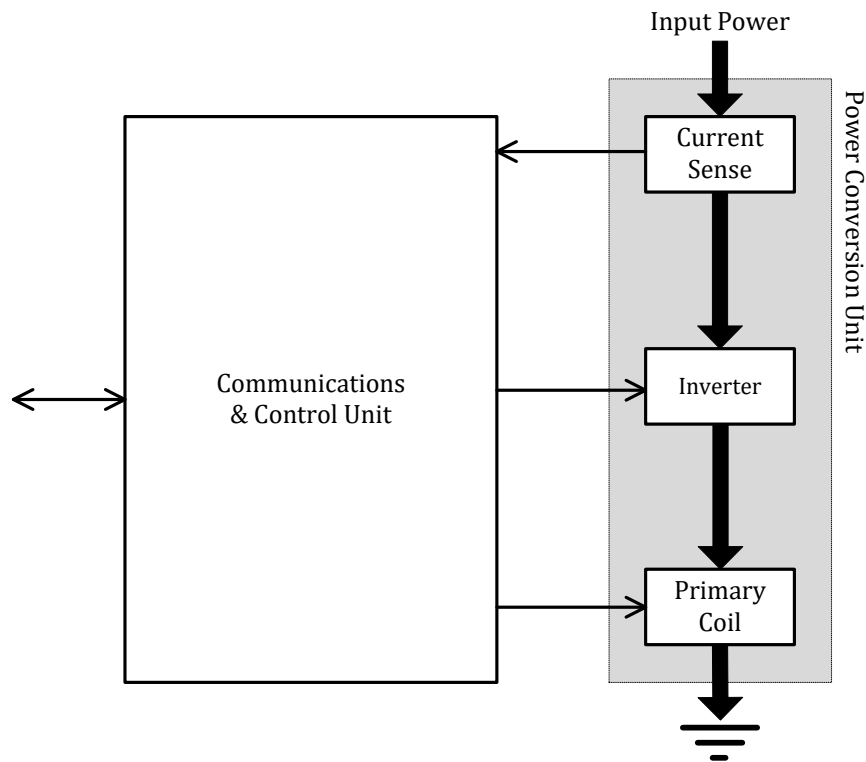

The Power Conversion Unit on the right-hand side of Figure 88 comprises the analog parts of the design. The voltage and current sense monitors the input voltage and current. The inverter converts the DC input to an AC waveform that drives a resonant circuit, which consists of the Primary Coil plus a series capacitor.

The Communications and Control Unit on the left-hand side of Figure 88 comprises the digital logic part of the design. The unit receives and decodes messages from the Power Receiver, executes the relevant power control algorithms and protocols, and drives the input power and frequency of the AC waveform to control the power transfer. The Communications and Control Unit also interfaces with other subsystems of the Base Station, e.g. for user interface purposes.

2.2.24.1 Mechanical details

Power Transmitter design A24 includes one Primary Coil as defined in Section 2.2.24.1.1, Shielding as defined in Section 2.4.3.1.2, and an Interface Surface as defined in Section 2.2.24.1.3.

2.2.24.1.1 Primary Coil

The Primary Coil is of the wire-wound type, and consists of litz wire having 105 strands of 0.08 mm diameter, or equivalent. As shown in Figure 89, a Primary Coil has a circular shape and consists of a single layer. Table 63 lists the dimensions of a Primary Coil.

Figure 89. Primary Coil of Power Transmitter design A24

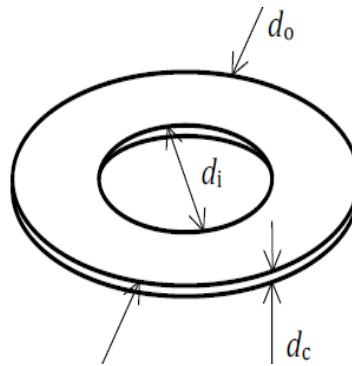

Table 63. Primary Coil parameters of Power Transmitter design A24

Parameter	Symbol	Value
Outer diameter	d_o	$44.0^{\pm 1.5}$ mm
Inner diameter	d_i	$22.5^{\pm 1.0}$ mm
Thickness	d_c	$1.3^{\pm 0.15}$ mm
Number of turns per layer	N	9
Number of layers	-	1

2.2.24.1.2 Shielding

As shown in Figure 90, Shielding protects the Base Station from the magnetic field that is generated in the Primary Coil. The Shielding should be Ni-Zn or Mn-Zn ferrite and should be at least 0.5 mm thick. The Shielding extends to at least 2.0 mm beyond the outer edge of the Primary Coil.

Figure 90. Primary Coil assembly of Power Transmitter design A24

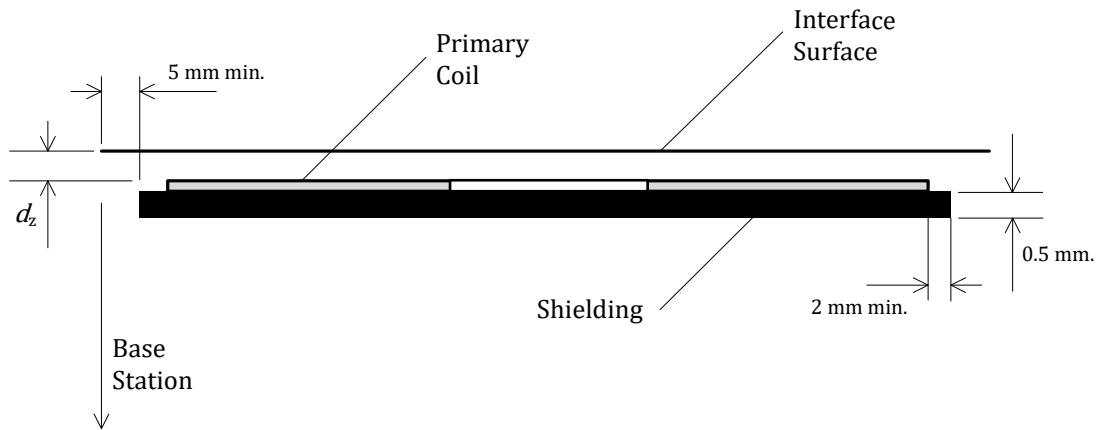

2.2.24.1.3 Interface Surface

As shown in Figure 90, the distance from the Primary Coil to the Interface Surface of the Base Station is $d_z = 3.0^{\pm 0.5}$ mm, across the top face of the Primary Coil. In addition, the Interface Surface of the Base Station extends at least 5 mm beyond the outer diameter of the Primary Coil.

2.2.24.1.4 Separation between multiple Power transmitters

If the Base Station contains multiple type A24 Power Transmitters, the Primary Coils of any pair of those Power Transmitters shall have a center-to-center distance of at least 50 mm.

2.2.24.2 Electrical details

As shown in Figure 91, Power Transmitter design A24 uses a full-bridge inverter to drive the Primary Coil and a series capacitance. Within the Operating Frequency range Specified below, the assembly of Primary Coil and Shielding has a self inductance $L_p = 6.1^{\pm 10\%}$ μH . The value of the series capacitance is $C_p = 400^{\pm 10\%}$ nF. The input voltage to the full-bridge is $5.0^{\pm 5\%}$ V.

NOTE Near resonance, the voltage developed across the series capacitance can reach levels up to 100 V pk-pk.

Power Transmitter design A24 uses the Operating Frequency and duty cycle of the Power Signal in order to control the amount of power transferred. For this purpose, the Operating Frequency range is $f_{op} = 110 \dots 205$ kHz, and the duty cycle range is $2 \dots 50\%$. A higher Operating Frequency and lower duty cycle result in the transfer of a lower amount of power. In order to achieve a sufficiently accurate adjustment of the power that is transferred, a type A24 Power Transmitter shall be able to control the Operating Frequency with a resolution of 0.1 kHz or better.

When a type A24 Power Transmitter first applies a Power Signal (Digital Ping; see *Parts 1 and 2: Interface Definitions*), the Power Transmitter shall use an Operating Frequency of $155^{\pm 15}$ kHz, and a duty cycle of $30^{\pm 10}\%$. If the Power Transmitter does not receive a Signal Strength Packet from the Power Receiver, the Power Transmitter shall remove the Power Signal as defined in *Parts 1 and 2: Interface Definitions*. The Power transmitter may re-apply the power signal multiple times at consecutively Operating Frequencies within the range specified above, until the Power Transmitter receives a Signal Strength Packet containing an appropriate Signal Strength Value.

Control of the power transfer shall proceed using the PID algorithm, which is defined in *Parts 1 and 2: Interface Definitions*. The controlled variable $v^{(i)}$ introduced in the definition of that algorithm represents the input voltage to the full-bridge inverter, Operating Frequency and duty cycle. It is recommended that control of the power occurs primarily by means of adjustments to the duty cycle. In order to guarantee sufficiently accurate power control, a type A24 Power Transmitter shall determine the amplitude of the Primary Coil current with a resolution of 5 mA or better. Finally, Table 64 and Table 65 provide the values of several parameters, which are used in the PID algorithm.

Figure 91. Electrical diagram (outline) of Power Transmitter design A24

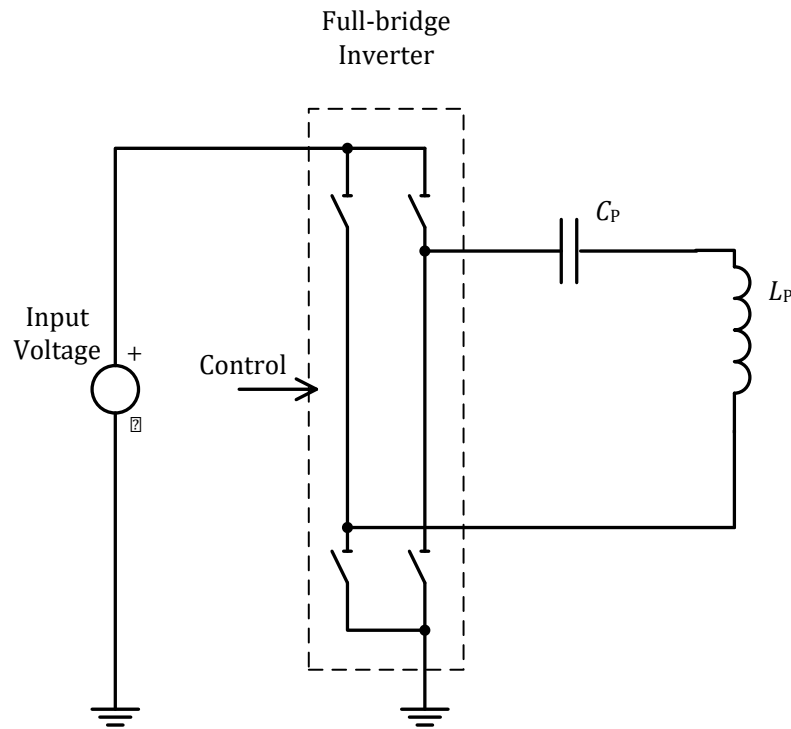

Table 64. PID parameters for Operating Frequency control

Parameter	Symbol	Value	Unit
Proportional gain	K_p	1	mA^{-1}
Integral gain	K_i	0	$\text{mA}^{-1}\text{ms}^{-1}$
Derivative gain	K_d	0	mA^{-1}ms
Integral term limit	M_I	N.A.	N.A.
PID output limit	M_{PID}	20,000	N.A.
Scaling factor	S_v	1.0	Hz

Table 65. PID parameters for duty cycle control

Parameter	Symbol	Value	Unit
Proportional gain	K_p	1	mA^{-1}
Integral gain	K_i	0	$\text{mA}^{-1}\text{ms}^{-1}$
Derivative gain	K_d	0	mA^{-1}ms
Integral term limit	M_I	N.A.	N.A.
PID output limit	M_{PID}	20,000	N.A.
Scaling factor	S_v	-0.1	°

2.2.25 Power Transmitter design A25

Figure 92 illustrates the functional block diagram of Power Transmitter design A25, which consists of two major functional units, namely a Power Conversion Unit and a Communications and Control Unit.

Figure 92. Functional block diagram of Power Transmitter design A25

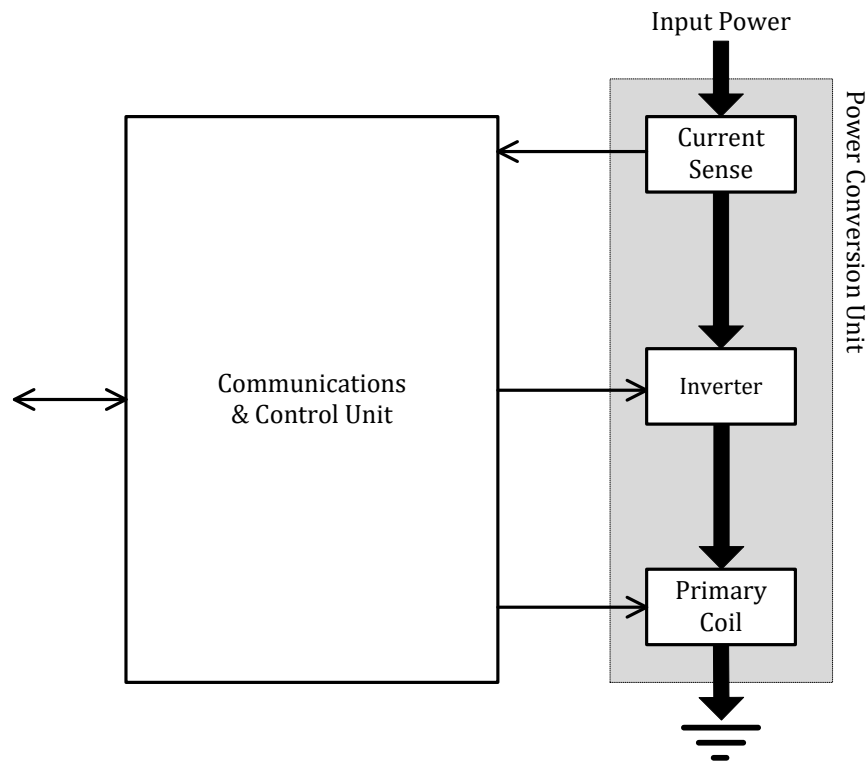

The Power Conversion Unit on the right-hand side of Figure 92 comprises the analog parts of the design. The voltage and current sense monitors the input voltage and current. The inverter converts the DC input to an AC waveform that drives a resonant circuit, which consists of the Primary Coil plus a series capacitor.

The Communications and Control Unit on the left-hand side of Figure 92 comprises the digital logic part of the design. The unit receives and decodes messages from the Power Receiver, executes the relevant power control algorithms and protocols, and drives the input power and frequency of the AC waveform to control the power transfer. The Communications and Control Unit also interfaces with other subsystems of the Base Station, e.g. for user interface purposes.

2.2.25.1 Mechanical details

Power Transmitter design A25 includes one Primary Coil as defined in Section 2.2.25.1.1, Shielding as defined in Section 2.2.25.1.2, and an Interface Surface as defined in Section 2.2.25.1.3.

2.2.25.1.1 Primary Coil

The Primary Coil is of the wire-wound type, and consists of litz wire having 115 strands of 0.08 mm diameter, or equivalent. As shown in Figure 93, a Primary Coil has a racetrack-like shape and consists of a single layer. Table 66 lists the dimensions of a Primary Coil.

Figure 93. Primary Coil of Power Transmitter design A25

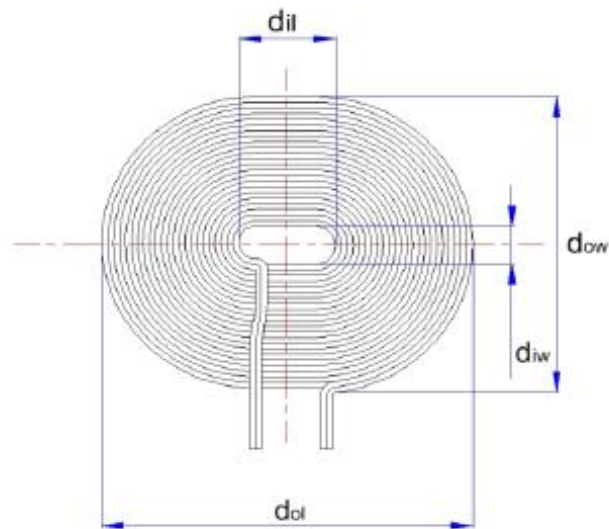

Table 66. Primary Coil parameters of Power Transmitter design A25

Parameter	Symbol	Value
Outer length	d_{ol}	$65.7^{\pm 1.5}$ mm
Inner length	d_{il}	$16.3^{\pm 1.0}$ mm
Outer width	d_{ow}	$59.2^{\pm 1.5}$ mm
Inner width	d_{iw}	$5.1^{\pm 1.0}$ mm
Thickness	d_c	$1.3^{\pm 0.15}$ mm
Number of turns per layer	N	11 (bifilar turns)
Number of layers	–	1

2.2.25.1.2 Shielding

As shown in Figure 94, Shielding protects the Base Station from the magnetic field that is generated in the Primary Coil. The Shielding should be Ni-Zn or Mn-Zn ferrite and should be at least 2.0 mm thick. The Shielding extends to at least 2.5 mm beyond the outer edge of the Primary Coil.

Figure 94. Primary Coil assembly of Power Transmitter design A25

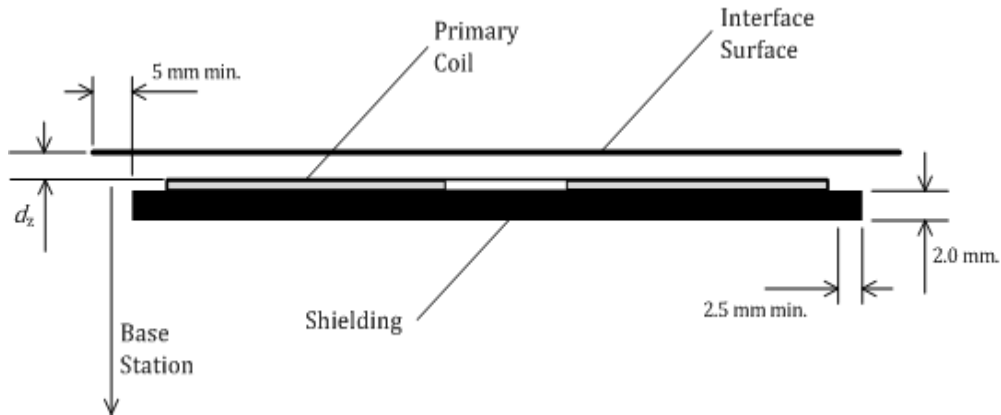

2.2.25.1.3 Interface Surface

As shown in Figure 94, the distance from the Primary Coil to the Interface Surface of the Base Station is $d_z = 2.5 \pm 1.0$ mm, across the top face of the Primary Coil. In addition, the Interface Surface of the Base Station extends at least 5 mm beyond the outer diameter of the Primary Coil.

2.2.25.1.4 Separation between multiple Power transmitters

If the Base Station contains multiple type A25 Power Transmitters, the Primary Coils of any pair of those Power Transmitters shall have a center-to-center distance of at least 67.2 mm.

2.2.25.2 Electrical details

As shown in Figure 95, Power Transmitter design A25 uses a full-bridge inverter to drive the Primary Coil and a series capacitance. Within the Operating Frequency range Specified below, the assembly of Primary Coil and Shielding has a self inductance $L_p = 6.1^{\pm 10\%}$ μH . The value of the series capacitance is $C_p = 400^{\pm 10\%}$ nF. The input voltage to the full-bridge is $5.0^{\pm 5.0\%}$ V.

NOTE Near resonance, the voltage developed across the series capacitance can reach levels up to 100 V pk-pk.

Power Transmitter design A25 uses the Operating Frequency and duty cycle of the Power Signal in order to control the amount of power transferred. For this purpose, the Operating Frequency range is $f_{op} = 110 \dots 205$ kHz, and the duty cycle range is 2 ... 50%. A higher Operating Frequency and lower duty cycle result in the transfer of a lower amount of power. In order to achieve a sufficiently accurately adjustment of the power that is transferred, a type A25 Power Transmitter shall be able to control the Operating Frequency with a resolution of 0.1kHz or better.

When a type A25 Power Transmitter first applies a Power Signal (Digital Ping; see *Parts 1 and 2: Interface Definitions*), the Power Transmitter shall use an Operating Frequency of $155^{\pm 15}$ kHz, and a duty cycle of $30^{\pm 10}\%$. If the Power Transmitter does not receive a Signal Strength Packet from the Power Receiver, the Power Transmitter shall remove the Power Signal as defined in *Parts 1 and 2: Interface Definitions*. The Power Transmitter may re-apply the power signal multiple times at consecutively lower Operating Frequencies within the range specified above, until the Power Transmitter receives a Signal Strength Packet containing an appropriate Signal Strength Value.

Control of the power transfer shall proceed using the PID algorithm, which is defined in *Parts 1 and 2: Interface Definitions*. The controlled variable $v^{(i)}$ introduced in the definition of that algorithm represents the input voltage to the full-bridge inverter, Operating Frequency and duty cycle. It is recommended that control of the power occurs primarily by means of adjustments to the duty cycle. In order to guarantee sufficiently accurate power control, a type A25 Power Transmitter shall determine the amplitude of the Primary Coil current with a resolution of 5 mA or better. Finally, Table 67 and Table 68 provide the values of several parameters, which are used in the PID algorithm.

Figure 95. Electrical diagram (outline) of Power Transmitter design A25

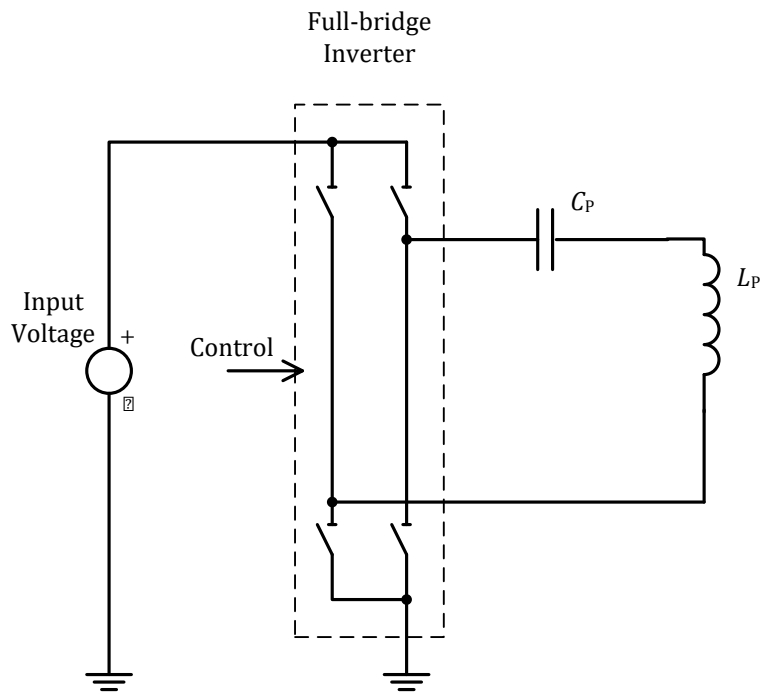

Table 67. PID parameters for Operating Frequency control

Parameter	Symbol	Value	Unit
Proportional gain	K_p	1	mA^{-1}
Integral gain	K_i	0	$\text{mA}^{-1}\text{ms}^{-1}$
Derivative gain	K_d	0	mA^{-1}ms
Integral term limit	M_I	N.A.	N.A.
PID output limit	M_{PID}	20,000	N.A.
Scaling factor	S_v	1.0	Hz

Table 68. PID parameters for duty cycle control

Parameter	Symbol	Value	Unit
Proportional gain	K_p	1	mA^{-1}
Integral gain	K_i	0	$\text{mA}^{-1}\text{ms}^{-1}$
Derivative gain	K_d	0	mA^{-1}ms
Integral term limit	M_I	N.A.	N.A.
PID output limit	M_{PID}	20,000	N.A.
Scaling factor	S_v	-0.1	°

2.2.26 Power Transmitter design A26

Figure 96 illustrates the functional block diagram of Power Transmitter design A26, which consists of two major functional units, namely a Power Conversion Unit and a Communications and Control Unit.

Figure 96. Functional block diagram of Power Transmitter design A26

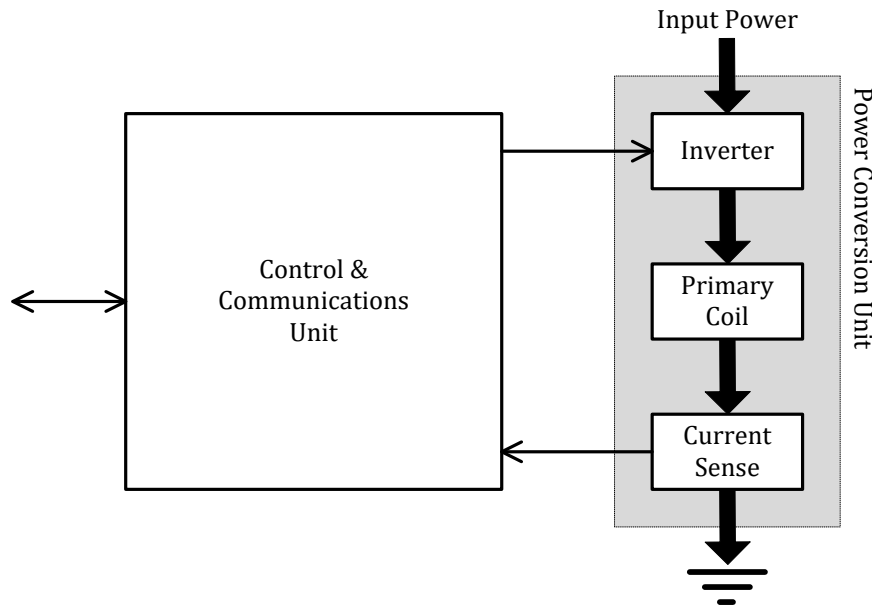

The Power Conversion Unit on the right-hand side of Figure 96 comprises the analog parts of the design. The inverter converts the DC input to an AC waveform that drives a resonant circuit, which consists of the Primary Coil plus a series capacitor. Finally, the current sense monitors the Primary Coil current.

The Communications and Control Unit on the left-hand side of Figure 96 comprises the digital logic part of the design. This unit receives and decodes messages from the Power Receiver, executes the relevant power control algorithms and protocols, and drives the frequency of the AC waveform to control the power transfer. The Communications and Control Unit also interfaces with other subsystems of the Base Station, e.g. for user interface purposes.

2.2.26.1 Mechanical details

Power Transmitter design A26 includes a single Primary Coil as defined in Section 2.2.26.1.1, Shielding as defined in Section 2.2.26.1.2, an Interface Surface as defined in Section 2.2.26.1.3, and an alignment aid as defined in Section 2.2.26.1.4.

2.2.26.1.1 Primary Coil

The Primary Coil is of the wire-wound type, and consists of litz wire having 105 strands of no. 40 AWG (0.08 mm diameter), or equivalent. As shown in Figure 97, the Primary Coil has a triangular shape and consists of a single layer. Table 69 lists the dimensions of the Primary Coil.

Figure 97. Primary Coil of Power Transmitter design A26

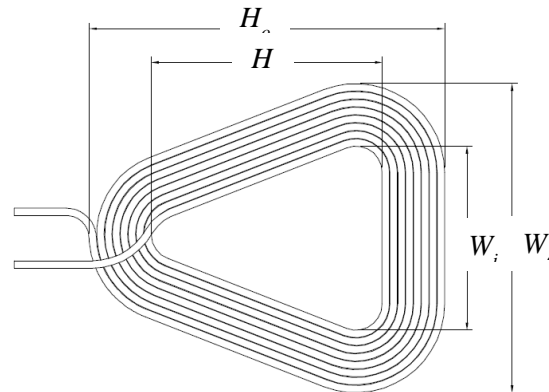

Table 69. Primary Coil parameters of Power Transmitter design A26

Parameter	Symbol	Value
Outer height	H_o	52 ± 0.5 mm
Inner height	H_i	34 ± 0.5 mm
Outer width	W_o	46 ± 0.5 mm
Inner width	W_i	28 ± 0.5 mm
Thickness	d_c	1.1 ± 0.3 mm
Number of turns per layer	N	8
Number of layers	-	1

2.2.26.1.2 Shielding

As shown in Figure 98, Shielding protects the Base Station from the magnetic field that is generated in the Primary Coil. The Shielding should be Ni-Zn or Mn-Zn ferrite and should be at least 0.7 mm thick. The Shielding extends to at least 2.5 mm beyond the outer diameter of the Primary Coil, and is placed below the Primary Coil at a distance of at most $d_s = 1.0$ mm.

Figure 98. Primary Coil assembly of Power Transmitter design A26

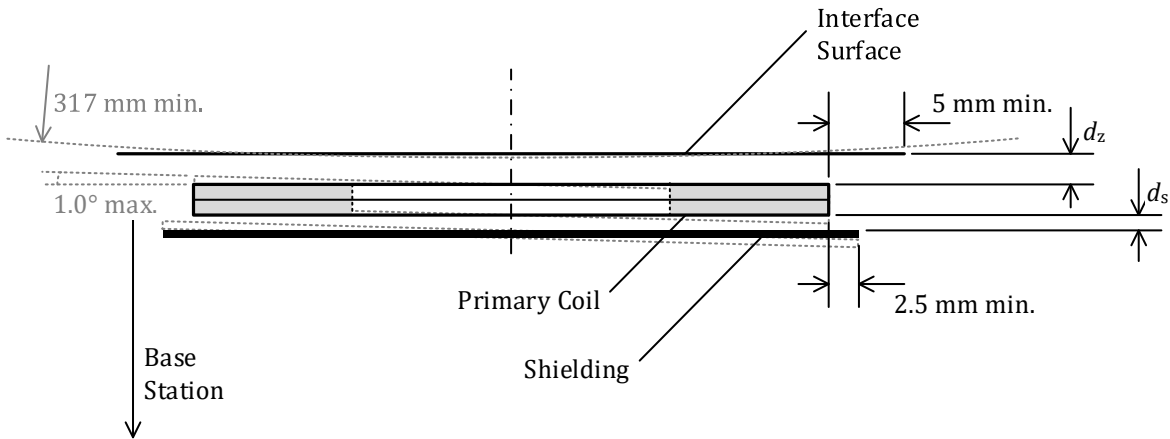

2.2.26.1.3 Interface Surface

As shown in Figure 98, the distance from the Primary Coil to the Interface Surface of the Base Station is $d_z = 2^{+0.5}_{-0.5}$ mm, across the top face of the Primary Coil. In addition, the Interface Surface of the Base Station extends at least 5 mm beyond the outer diameter of the Primary Coil.

NOTE This Primary-Coil-to-Interface-Surface distance implies that the tilt angle between the Primary Coil and a flat Interface Surface is at most 1.0°. Alternatively, in case of a non-flat Interface Surface, this Primary-Coil-to-Interface-Surface distance implies a radius of curvature of the Interface Surface of at least 317 mm, centered on the Primary Coil. See Figure 98.

2.2.26.1.4 Alignment aid

The user manual of the Base Station containing a type A26 Power Transmitter shall have information about the location of its Active Area(s).

For the best user experience, it is recommended to employ at least one user feedback mechanism during Mobile Device positioning to help alignment.

NOTE Examples of Base Station alignment aids to assist the user positioning of the Mobile Device include:

- A marked Interface Surface to indicate the location of the Active Area(s)—e.g. by means of the logo or other visual marking, lighting, etc.
- A visual feedback display—e.g. by means of illuminating an LED to indicate proper alignment.
- An audible or haptic feedback mechanism.

2.2.26.1.5 Inter coil separation

If the Base Station contains multiple type A26 Power Transmitters, the Primary Coils of any pair of those Power Transmitters shall not overlap.

2.2.26.2 Electrical details

As shown in Figure 99, Power Transmitter design A26 uses a full-bridge inverter to drive the Primary Coil and a series capacitance. Within the Operating Frequency range specified below, the assembly of Primary Coil, Shielding, and magnet has a self inductance $L_p = 6.3^{\pm 10\%}$ μH . The value of the series capacitance is $C_p = 0.4^{\pm 5\%}$ μF . The input voltage to the full-bridge inverter is $5^{\pm 5\%}$ V.

NOTE Near resonance, the voltage developed across the series capacitance can reach levels exceeding 100 V pk-pk.

Power Transmitter design A26 uses the Operating Frequency and duty cycle of the Power Signal in order to control the amount of power that is transferred. For this purpose, the Operating Frequency range of the full-bridge inverter is $f_{op} = 110 \dots 205$ kHz with a duty cycle of 50%; and its duty cycle range is 10...50% at an Operating Frequency of 205 kHz. A higher Operating Frequency or lower duty cycle result in the transfer of a lower amount of power. In order to achieve a sufficiently accurate adjustment of the amount of power that is transferred, a type A26 Power Transmitter shall control the Operating Frequency with a resolution of

- $0.01 \times f_{op} - 0.7$ kHz, for f_{op} in the 110...175 kHz range;
- $0.015 \times f_{op} - 1.58$ kHz, for f_{op} in the 175...205 kHz range;

or better. In addition, a type A26 Power Transmitter shall control the duty cycle of the Power Signal with a resolution of 0.1% or better.

When a type A26 Power Transmitter first applies a Power Signal (see *Parts 1 and 2: Interface Definitions*), it shall use an initial Operating Frequency of 175 kHz (and a duty cycle of 50%).

Control of the power transfer shall proceed using the PID algorithm, which is defined in *Parts 1 and 2: Interface Definitions*. The controlled variable $v^{(i)}$ introduced in the definition of that algorithm represents the Operating Frequency or the duty cycle. In order to guarantee sufficiently accurate power control, a type A16 Power Transmitter shall determine the amplitude of the Primary Cell current—which is equal to the Primary Coil current—with a resolution of 7 mA or better. Finally, Table 70, Table 71, and Table 72 provide the values of several parameters, which are used in the PID algorithm.

Figure 99. Electrical diagram (outline) of Power Transmitter design A26

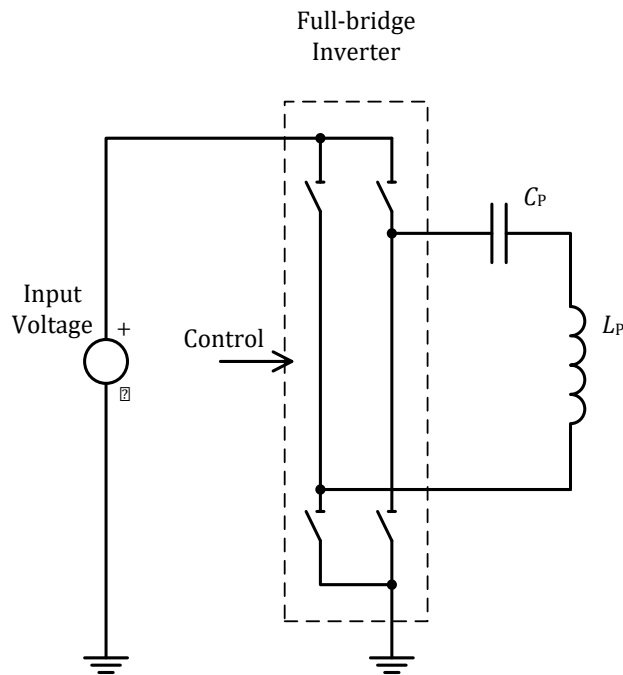

Table 70. PID parameters for Operating Frequency control

Parameter	Symbol	Value	Unit
Proportional gain	K_p	10	mA^{-1}
Integral gain	K_i	0.05	$\text{mA}^{-1}\text{ms}^{-1}$
Derivative gain	K_d	0	mA^{-1}ms
Integral term limit	M_I	3,000	N.A.
PID output limit	M_{PID}	20,000	N.A.

Table 71. Operating Frequency dependent scaling factor

Frequency Range [kHz]	Scaling Factor S_v [Hz]
110...140	1.5
140...160	2
160...180	3
180...205	5

Table 72. PID parameters for duty cycle control

Parameter	Symbol	Value	Unit
Proportional gain	K_p	10	mA^{-1}
Integral gain	K_i	0.05	$\text{mA}^{-1}\text{ms}^{-1}$
Derivative gain	K_d	0	mA^{-1}ms
Integral term limit	M_I	3,000	N.A.
PID output limit	M_{PID}	20,000	N.A.
Scaling factor	S_v	-0.01	%

2.2.27 Power Transmitter design A27

Figure 100 illustrates the functional block diagram of Power Transmitter design A27, which consists of two major functional units, namely a Power Conversion Unit and a Communications and Control Unit.

Figure 100. Functional block diagram of Power Transmitter design A27

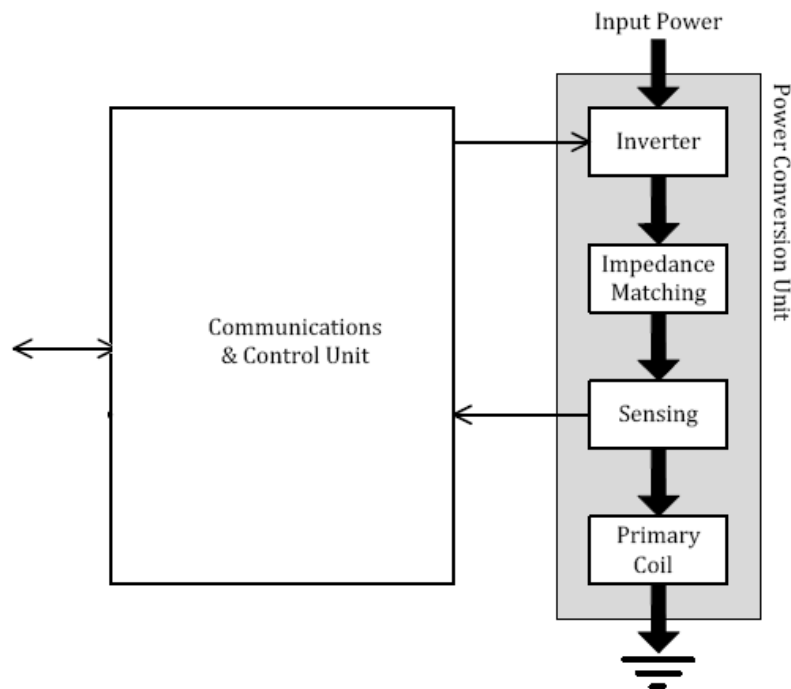

The Power Conversion Unit on the right-hand side of Figure 100 comprises the analog parts of the design. The impedance matching network forms a resonant circuit with the Primary Coil. The sensing circuits monitor (amongst others) the Primary Coil current and voltage, and the inverter converts the DC input to an AC waveform that drives the Primary Coil.

The Communications and Control Unit on the left-hand side of Figure 100 comprises the digital logic part of the design. This unit receives and decodes messages from the Power Receiver, executes the relevant power control algorithms and protocols, and drives the inverter to control the amount of power provided to the Power Receiver. The Communications and Control Unit also interfaces with the other subsystems of the Base Station, e.g. for user interface purposes.

2.2.27.1 Mechanical details

Power Transmitter design A27 includes a Primary Coil array as defined in Section 2.2.27.1.1, Shielding as defined in Section 2.2.27.1.2, and an Interface Surface as defined in Section 2.2.27.1.3.

2.2.27.1.1 Primary Coil

The Primary Coil is of the wire-wound type, and consists of 17 AWG (1.15 mm diameter) type 2 litz wire having 105 strands of no. 40 AWG (0.08 mm diameter), or equivalent. As shown in Figure 101, the Primary Coil has a circular shape and consists of one layer. Table 73 lists the dimensions of the Primary Coil.

Figure 101. Primary Coil of Power Transmitter design A27

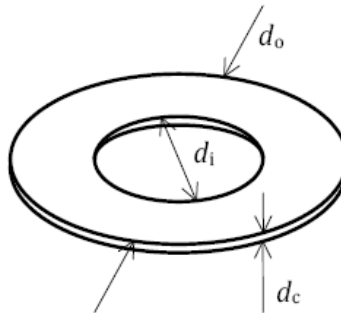

Table 73. Primary Coil parameters of Power Transmitter design A27

Parameter	Symbol	Value
Outer diameter	d_o	$60.0^{+3.0}_{-0.0}$ mm
Inner diameter	d_i	$20.5^{+0.5}$ mm
Number of turns	N	18
Thickness	d_c	$1.2^{+0.2}$ mm
Number of layers	-	1

2.2.27.1.2 Shielding

As shown in Figure 102, Transmitter design A27 employs Shielding to protect the Base Station from the magnetic field that is generated in the Primary Coil. The Shielding should be Ni-Zn or Mn-Zn ferrite and should be at least 0.5 mm thick. The Shielding extends to at least 2 mm beyond the outer edges of the Primary Coil array, and is placed at a distance of at most $d_s = 0.5$ mm below the Primary Coil array.

Figure 102. Primary Coil array assembly of Power Transmitter design A27

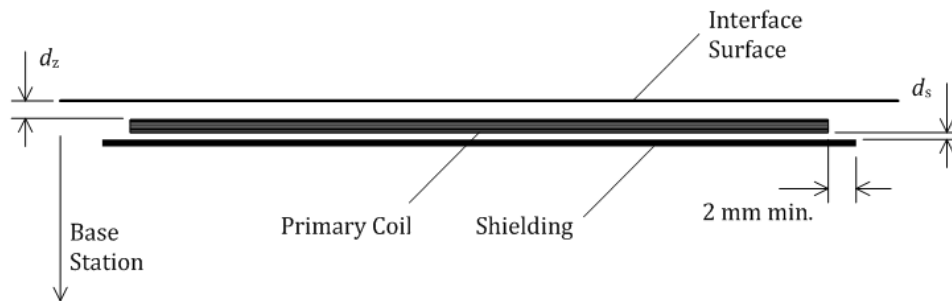

2.2.27.1.3 Interface Surface

As shown in Figure 102, the distance from the Primary Coil to the Interface Surface of the Base Station is $d_z = 2^{+0.5}_{-0.5}$ mm, across the top face of the Primary Coil. In addition, the Interface Surface extends at least 5 mm beyond the outer edges of the Primary Coil array.

2.2.27.1.4 Alignment aid

The user manual of the Base Station containing a type A27 Power Transmitter shall have information about the location of its Active Area(s).

For the best user experience, it is recommended to employ at least one user feedback mechanism during Mobile Device positioning to help alignment.

NOTE Examples of Base Station alignment aids to assist the user positioning of the Mobile Device include:

- A marked Interface Surface to indicate the location of the Active Area(s)—e.g. by means of the logo or other visual marking, lighting, etc.
- A visual feedback display—e.g. by means of illuminating an LED to indicate proper alignment.
- An audible or haptic feedback mechanism.

2.2.27.1.5 Inter coil separation

If the Base Station contains multiple type A27 Power Transmitters, the Primary Coils of any pair of those Power Transmitters shall have a center-to-center distance of at least 70 mm.

2.2.27.2 Electrical details

As shown in Figure 103, Power Transmitter design A27 uses a full-bridge inverter to drive the resonant network including filter inductor, a Primary Coil with a series and parallel capacitance. Within the Operating Frequency range $f_{op} = 110 \dots 120$ kHz, the assembly of Primary Coil and Shielding has an inductance of $24.0^{\pm 10\%}$ μH . The inductance and capacitances in the impedance matching circuit are, respectively, $L_m = 8.2^{\pm 20\%}$ μH , $C_{ser} = 100^{\pm 5\%}$ nF and $C_{par} = 100^{\pm 5\%}$ nF. The input voltage to the full-bridge inverter is $12^{\pm 5\%}$ V.

NOTE Near resonance, the voltage developed across the series capacitance can reach levels exceeding 100V pk-pk.

Power Transmitter design A27 uses the phase difference between the control signals to two halves of the full-bridge inverter to control the amount of power that is transferred, see Figure 104. For this purpose, the range of the phase difference α is $0 \dots 180^\circ$ —with a larger phase difference resulting in a lower power transfer. In order to achieve a sufficient accurate adjustment of the power that is transferred, a type A27 Power Transmitter shall be able to control the phase difference with a resolution of 0.42° or better. When a type A27 Power Transmitter first applies a Power Signal (Digital Ping; see *Parts 1 and 2: Interface Definitions*), it shall use an initial phase difference of 120° .

Control of the power transfer shall proceed using the PID algorithm, which is defined in *Parts 1 and 2: Interface Definitions*. The controlled variable $v^{(i)}$ introduced in the definition of that algorithm represents the phase difference between the two halves of the full-bridge inverter. In order to guarantee sufficiently accurate power control, a type A27 Transmitter shall determine the amplitude of the current into the Primary Coil with a resolution of 7 mA or better. Finally, Table 74 provides the values of several parameters, which are used in the PID algorithm.

Figure 103. Electrical diagram (outline) of Power Transmitter design A27

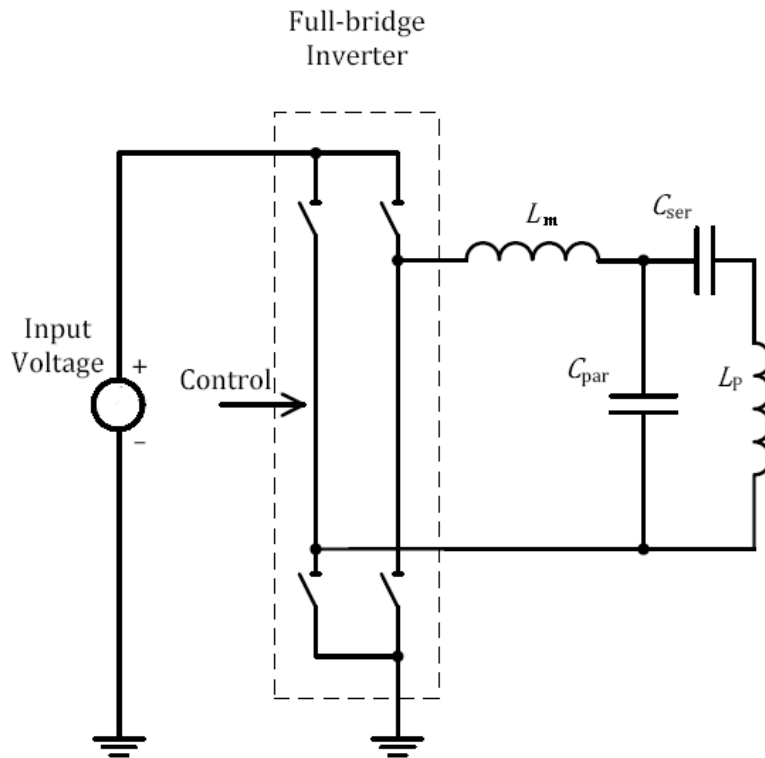

Figure 104. Control signals to the inverter

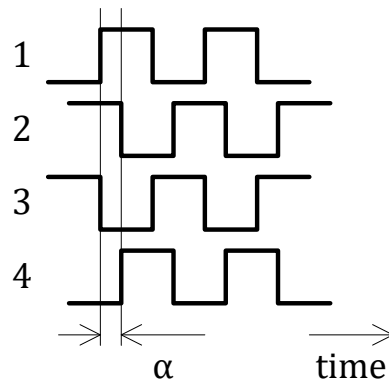

Table 74. Control parameters for power control

Parameter	Symbol	Value	Unit
Proportional gain	K_p	1	mA^{-1}
Integral gain	K_i	0	$\text{mA}^{-1}\text{ms}^{-1}$
Derivative gain	K_d	0	mA^{-1}ms
Integral term limit	M_I	N.A.	N.A.
PID output limit	M_{PID}	2,000	N.A.
Scaling factor	S_v	0.01	°

2.2.28 Power Transmitter design A28

Figure 105 illustrates the functional block diagram of this Power Transmitter design A28, which consists of two major functional units, namely a Power Conversion Unit and a Communications and Control Unit.

Figure 105. Functional block diagram of Power Transmitter design A28

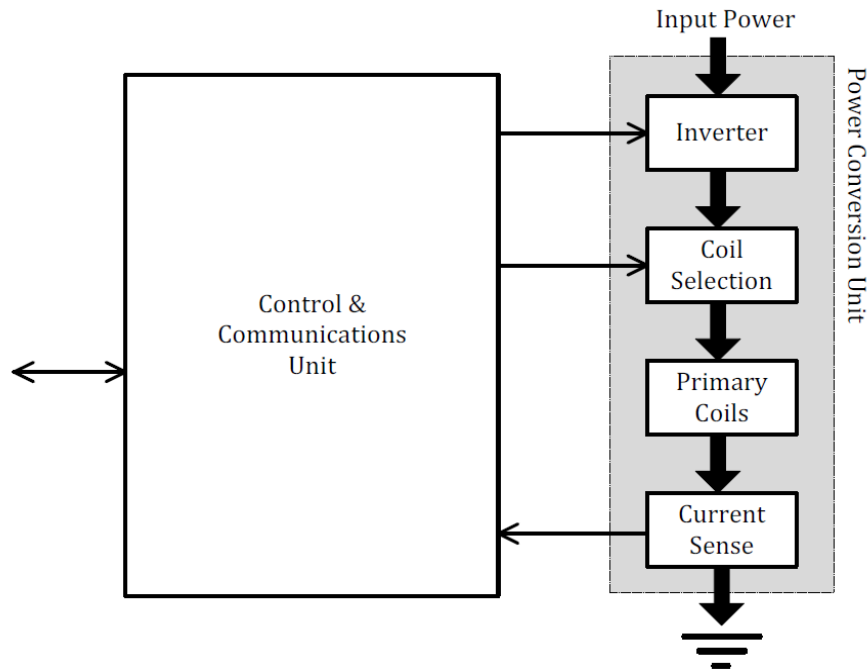

The Power Conversion Unit on the right-hand side of Figure 105 comprises the analog parts of the design. The inverter converts the DC input to an AC waveform that drives a resonant circuit, which consists of the selected Primary Coil plus a series capacitor. The selected Primary Coil is one from three partially overlapping Primary Coils, as appropriate for the position of the Power Receiver relative to the Primary Coils. Selection of the appropriate Primary Coil proceeds by the Power Transmitter attempting to establish communication with a Power Receiver using anyone of the Primary Coils. Finally, the current sense monitors the Primary Coil current.

The Communications and Control Unit on the left-hand side of Figure 105 comprises both analog circuit and digital logic. This unit receives and decodes messages from the Power Receiver, configures the Coil Selection block to connect the appropriate Primary Coil, executes the relevant power control algorithms and protocols, and drives the frequency of the AC waveform to control the power transfer. The Communications and Control Unit also interfaces with other subsystems of the Base Station, e.g. for user interface purposes.

2.2.28.1 Mechanical details

Power Transmitter design A28 includes one or more Primary Coils as defined in Section 2.2.28.1.1, Shielding as defined in Section 2.2.28.1.2, and Interface Surface as defined in Section 2.2.28.1.3.

2.2.28.1.1 Primary Coil

The Primary Coil is of the wire-wound type, and consists of no. 17 AWG (1.15 mm diameter) type 2 litz wire having 105 strands of no. 40 AWG (0.08 mm diameter), or equivalent. As shown in Figure 106, the Primary Coil has a rectangular shape and consists of a single layer. Table 75 lists the dimensions of the Primary Coil.

Figure 106. Primary Coil of Power Transmitter design A28

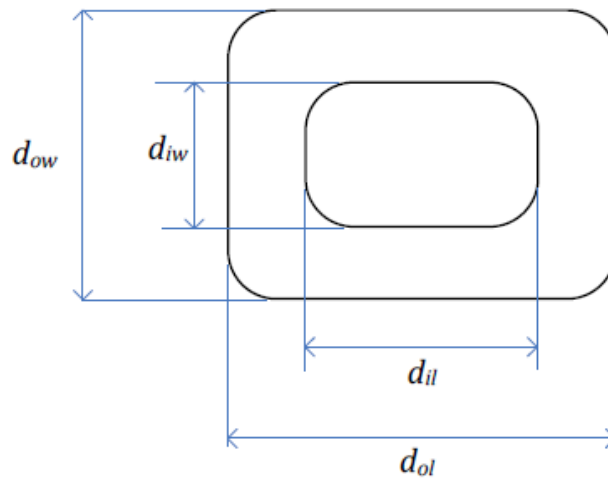
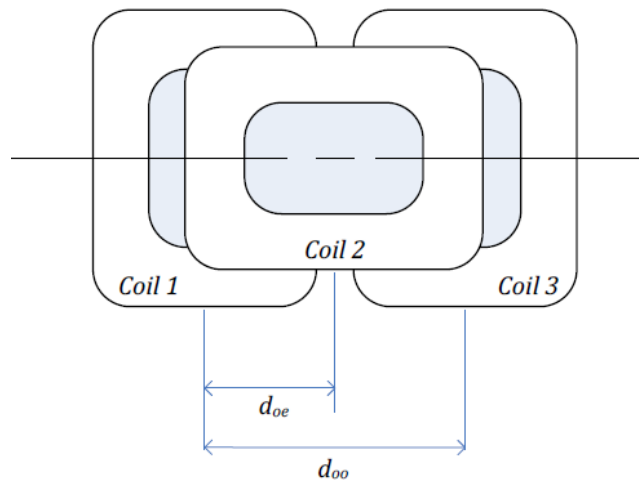

Table 75. Primary Coil parameters of Power Transmitter design A28

Parameter	Symbol	Value
Outer length	d_{ol}	$47.5^{\pm 1.0}$ mm
Inner length	d_{il}	$28.0^{\pm 1.0}$ mm
Outer width	d_{ow}	$39.5^{\pm 1.0}$ mm
Inner width	d_{iw}	$19.5^{\pm 1.0}$ mm
Thickness	d_c	$1.5^{\pm 0.5}$ mm
Number of turns per layer	N	9
Number of layers	-	1

Power Transmitter design A28 contains one or more Primary Coils. Power Transmitter design A28 contains at least one Primary Coil. Odd numbered coils are placed alongside each other with a displacement of $d_{oo} = 49.2^{\pm 4}$ mm between their centers. Even numbered coils are placed orthogonal to the odd numbered coils with a displacement of $d_{oe} = 24.6^{\pm 2}$ mm between their centers. See Figure 107.

Figure 107. Primary Coils of Power Transmitter design A28



2.2.28.1.2 Shielding

As shown in Figure 108, Shielding protects the Base Station from the magnetic field that is generated in the Primary Coils. The Shielding should be Ni-Zn or Mn-Zn ferrite and should be at least 0.5 mm thick. The Shielding extends to at least the outer dimensions of the Primary Coils, and is placed below the Primary Coils at a distance of at most $d_s = 1.0$ mm.

Figure 108. Primary Coil assembly of Power Transmitter design A28

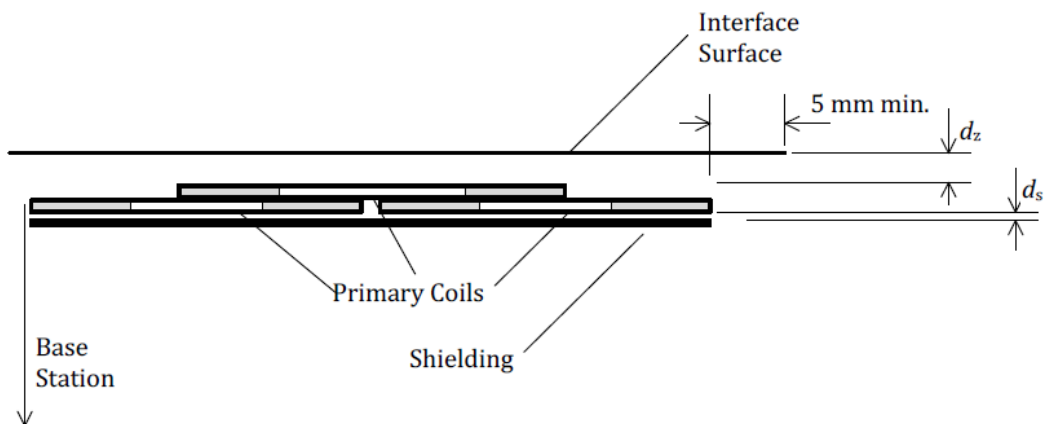

2.2.28.1.3 Interface Surface

As shown in Figure 108, the distance from the Primary Coil to the Interface Surface of the Base Station is $d_z = 2^{+0.5}_{-0.25}$ mm, across the top face of the Primary Coil. In addition, the Interface Surface of the Base Station extends at least 5 mm beyond the outer dimensions of the Primary Coils.

2.2.28.1.4 Inter coil separation

If the Base Station contains multiple type A28 Power Transmitters, the Primary Coils of any pair of those Power Transmitters shall have a center-to-center distance of at least $49.2^{\pm 4}$ mm.

2.2.28.2 Electrical details

As shown in Figure 109, Power Transmitter design A28 uses a full-bridge inverter to drive an individual Primary Coil and a series capacitance. Within the Operating Frequency range specified below, the assembly of Primary Coils and Shielding has a self inductance $6.4^{\pm 10\%}$ μH for coils closest to the Interface Surface and inductance $6.9^{\pm 10\%}$ μH for coils furthest from the Interface Surface. The value of the series capacitance is $400^{\pm 5\%}$ nF for coils closest to the Interface Surface and $357^{\pm 5\%}$ nF for coils furthest from the Interface Surface. The input voltage to the full-bridge inverter is $5^{\pm 5\%}$ V.

NOTE Near resonance, the voltage developed across the series capacitance can reach levels exceeding 100 V pk-pk.

Power Transmitter design A28 uses the Operating Frequency and duty cycle of the Power Signal in order to control the amount of power that is transferred. For this purpose, the Operating Frequency range of the full-bridge inverter is $f_{op} = 115 \dots 205$ kHz with a duty cycle of 50%; and its duty cycle range is 10...50% at an Operating Frequency of 205 kHz. A higher Operating Frequency or lower duty cycle result in the transfer of a lower amount of power. In order to achieve a sufficiently accurate adjustment of the amount of power that is transferred, a type A28 Power Transmitter shall control the Operating Frequency with a resolution of

- $0.01 \times f_{op} - 0.7$ kHz, for f_{op} in the 115...175 kHz range;
- $0.015 \times f_{op} - 1.58$ kHz, for f_{op} in the 175...205 kHz range;

or better. In addition, a type A28 Power Transmitter shall control the duty cycle of the Power Signal with a resolution of 0.1% or better.

When a type A28 Power Transmitter first applies a Power Signal (Digital Ping; see *Parts 1 and 2: Interface Definitions*), it shall use an initial Operating Frequency of 175 kHz (and a duty cycle of 50%).

Control of the power transfer shall proceed using the PID algorithm, which is defined in *Parts 1 and 2: Interface Definitions*. The controlled variable $v^{(i)}$ introduced in the definition of that algorithm represents the Operating Frequency or the duty cycle. In order to guarantee sufficiently accurate power control, a type A28 Power Transmitter shall determine the amplitude of the Primary Cell current—which is equal to the Primary Coil current—with a resolution of 7 mA or better. Finally, Table 76, Table 77, and Table 78 provide the values of several parameters, which are used in the PID algorithm.

Figure 109. Electrical diagram (outline) of Power Transmitter design A28

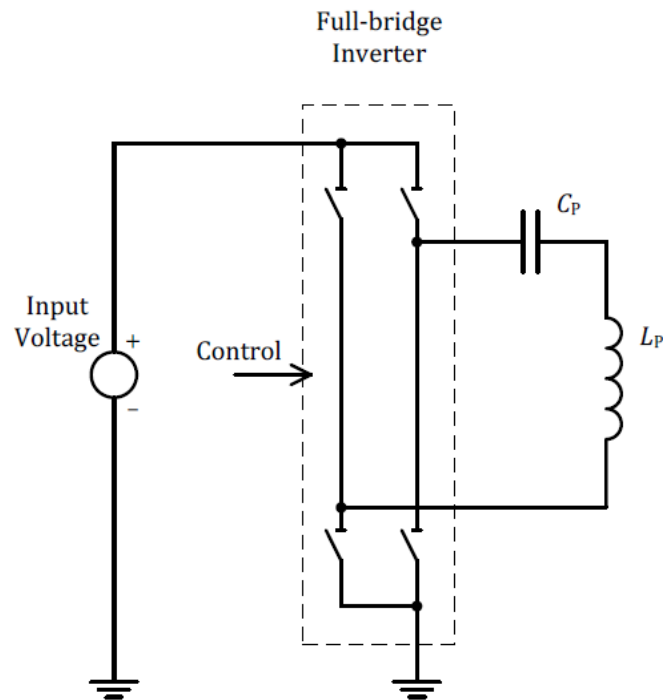

Table 76. PID parameters for Operating Frequency control

Parameter	Symbol	Value	Unit
Proportional gain	K_p	10	mA^{-1}
Integral gain	K_i	0.05	$\text{mA}^{-1}\text{ms}^{-1}$
Derivative gain	K_d	0	mA^{-1}ms
Integral term limit	M_I	3,000	N.A.
PID output limit	M_{PID}	20,000	N.A.

Table 77. Operating Frequency dependent scaling factor

Frequency Range [kHz]	Scaling Factor S_v [Hz]
115...140	1.5
140...160	2
160...180	3
180...205	5

Table 78. PID parameters for duty cycle control

Parameter	Symbol	Value	Unit
Proportional gain	K_p	10	mA^{-1}
Integral gain	K_i	0.05	$\text{mA}^{-1}\text{ms}^{-1}$
Derivative gain	K_d	0	mA^{-1}ms
Integral term limit	M_I	3,000	N.A.
PID output limit	M_{PID}	20,000	N.A.
Scaling factor	S_V	-0.01	%

2.2.29 Power Transmitter design A29

Figure 110 illustrates the functional block diagram of Power Transmitter Design A29.

Figure 110. Functional block diagram of Power Transmitter A29

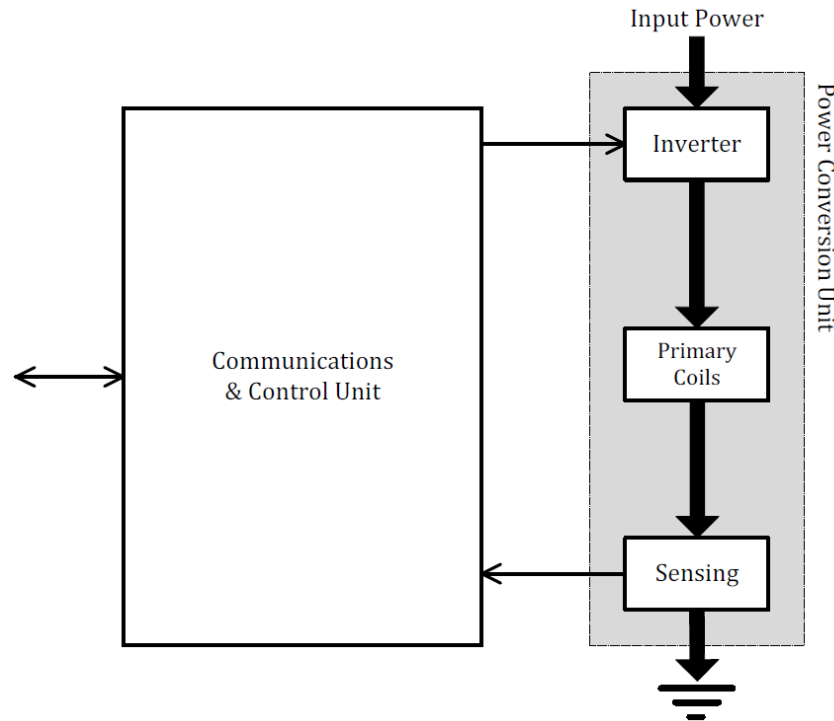

The Power Conversion Unit on the right-hand side of Figure 110 comprises the analog parts of the design. The inverter converts the DC input to an AC waveform that drives a resonant circuit, which consists of the Primary Coil plus a series capacitor. Finally, the voltage and current sense monitors the Primary Coil voltage and current.

The Communications and Control Unit on the left-hand side of Figure 110 comprises the digital logic part of the design. The unit receives and decodes messages from the Power Receiver, executes the relevant power control algorithms and protocols, and drives the input power and frequency of the AC waveform to control the power transfer. The Communications and Control Unit also interfaces with other subsystems of the Base Station, e.g. for user interface purposes.

2.2.29.1 Mechanical details

Power Transmitter design A29 includes a Primary Coil array as defined in Section 2.2.29.1.1, Shielding as defined in Section 2.2.29.1.2, and an Interface Surface as defined in Section 2.2.29.1.3.

2.2.29.1.1 Primary Coil

The Primary Coil is of the wire-wound type, and consists of litz wire with nylon spinning having 180 strands of no. 40 AWG (0.08 mm diameter), or equivalent. As shown in Figure 111 the Primary Coil has a circular shape and consists of two layers with a total of 13 turns. Table 79 lists the dimensions of the Primary Coil.

Figure 111. Primary Coil of Power Transmitter A29

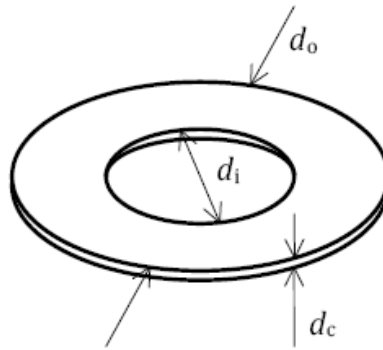

Table 79. Primary Coil parameters of Power Transmitter design A29

Parameter	Symbol	Value
Outer diameter	d_o	$41^{\pm 2}$ mm
Inner diameter	d_i	$21^{\pm 0.5}$ mm
Thickness	d_c	$3^{\pm 0.5}$ mm
Numbers of turns per layer	N	6.5
Number of layers	-	2

2.2.29.1.2 Shielding

As shown in Figure 112, Shielding protects the Base Station from the magnetic field that is generated in the Primary Coil. The Shielding should be Ni-Zn or Mn-Zn ferrite and should be at least 2.5 mm thick. The Shielding extends to at least 3.5 mm beyond the outer diameter of the Primary Coil, and is placed below the Primary Coil at a distance of at most $d_s = 1.0$ mm.

Figure 112. Primary Coil assembly of Power Transmitter design A29

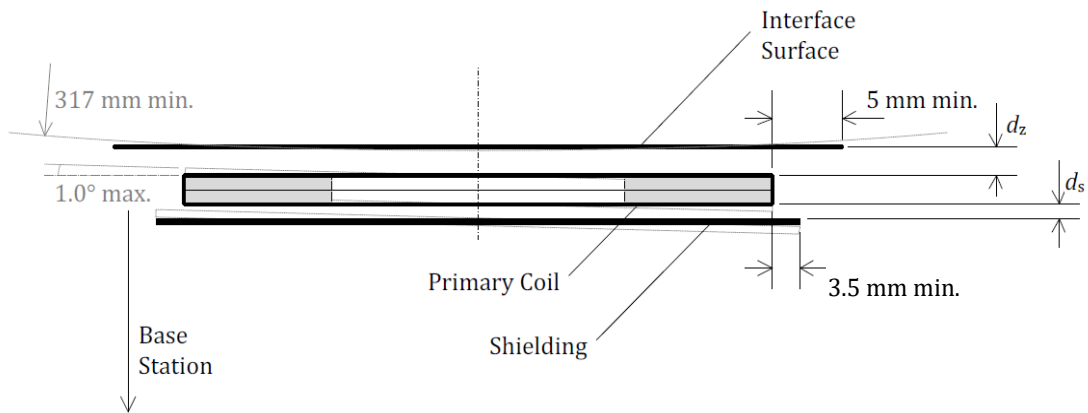

2.2.29.1.3 Interface Surface

As shown in Figure 112, the distance from the Primary Coil to the Interface Surface of the Base Station is $d_z = 2.5^{±0.5}$ mm, across the top face of the Primary Coil. In addition, the Interface Surface of the Base Station extends at least 5 mm beyond the outer diameter of the Primary Coil.

NOTE This Primary- Coil-to-Interface-Surface distance implies that the tilt angle between the Primary Coil and a flat Interface Surface is at most 1.0°. Alternatively, in case of a non-flat Interface Surface, this Primary-Coil-to-Interface-Surface distance implies a radius of curvature of the Interface Surface of at least 317 mm, centered on the Primary Coil. See Figure 112.

2.2.29.1.4 Alignment Aid

The user manual of the Base Station containing a type A29 Power Transmitter shall have information about the location of its Active Area(s).

For the best user experience, it is recommended to employ at least one user feedback mechanism during Mobile Device positioning to help alignment.

NOTE Examples of Base Station alignment aids to assist the user positioning of the Mobile Device include:

- A marked Interface Surface to indicate the location of the Active Area(s)—e.g. by means of the logo or other visual marking, lighting, etc.
- A visual feedback display—e.g. by means of illuminating an LED to indicate proper alignment.
- An audible or haptic feedback mechanism.

2.2.29.1.4.1 *Inter coil separation*

If the Base Station contains multiple type A29 Power Transmitters, the Primary Coils of any pair of those Power Transmitters shall have a center-to-center distance of at least 70 mm.

2.2.29.2 Electrical Details

As shown in Figure 113, Power Transmitter design A29 uses a full-bridge inverter to drive the resonant network with a primary Coil with a series capacitance. Within the Operating Frequency range specified below, the assembly of Primary Coil and Shielding, has a self inductance $L_p = 10^{\pm 10\%}$ μH . The value of the total series capacitance $C_p = 247^{\pm 5\%}$ nF, where the individual series capacitances may have any value less than the sum.

NOTE Near resonance, the voltage developed across the series capacitance can reach levels exceeding 100 V pk-pk.

Power Transmitter design A29 uses the input voltage to the inverter to control the amount of power transferred. For this purpose, the input voltage has a range $1^{\pm 5\%} \dots 12^{\pm 5\%}$ V, with a resolution of 40 mV or better; a higher input voltage results in more power transferred. The Operating Frequency is $130^{\pm 3\%}$ kHz with a duty cycle of 50%.

When a type A29 Power Transmitter first applies a Power Signal (Digital Ping; see *Parts 1 and 2: Interface Definitions*), it shall use an Operating Frequency of 130 kHz and a recommended input voltage of 4 V.

Control of the power transfer shall proceed using the PID algorithm, which is defined in *Parts 1 and 2: Interface Definitions*. The controlled variable $v^{(i)}$ introduced in the definition of that algorithm represents the input voltage. Finally, Table 80 provides the values of several parameters, which are used in the PID algorithm.

Figure 113. Electrical diagram (outline) Primary Coil of Power Transmitter design A29

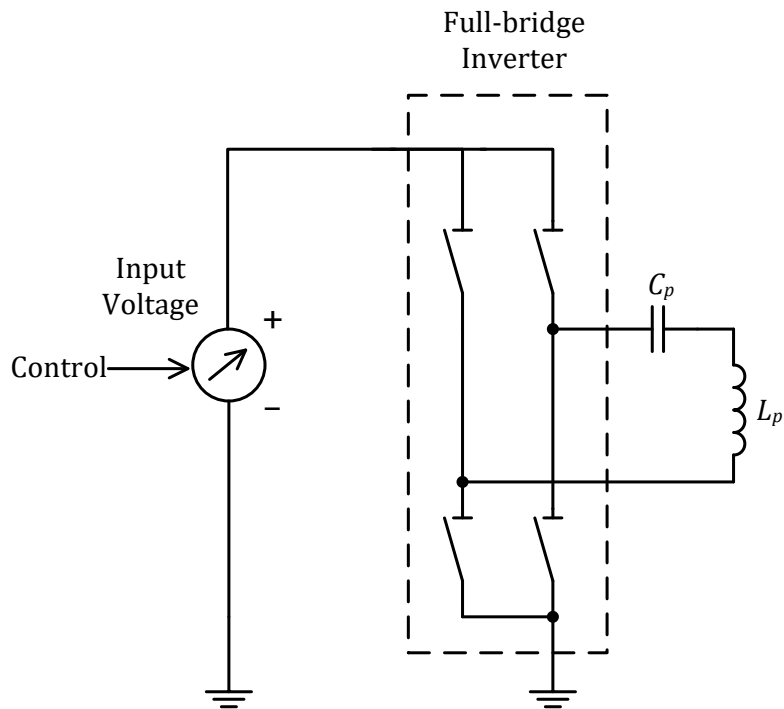

Table 80. PID parameters for voltage control

Parameter	Symbol	Value	Unit
Proportional Gain	K_p	10	mA^{-1}
Integral Gain	K_i	0.05	$\text{mA}^{-1}\text{ms}^{-1}$
Derivative Gain	K_d	0	$\text{mA}^{-1}\text{ms}^{-1}$
Integral Term Limit	M_I	3,000	N.A.
PID output limit	M_{PID}	20,000	N.A.
Scaling factor	S_v	0.01	%

2.2.30 Power Transmitter design A30

Figure 114 illustrates the functional block diagram of the Power Transmitter design A30, which consists of two major functional units, namely a Power Conversion Unit and a Communications and Control Unit.

Figure 114. Functional block diagram of Power Transmitter design A30

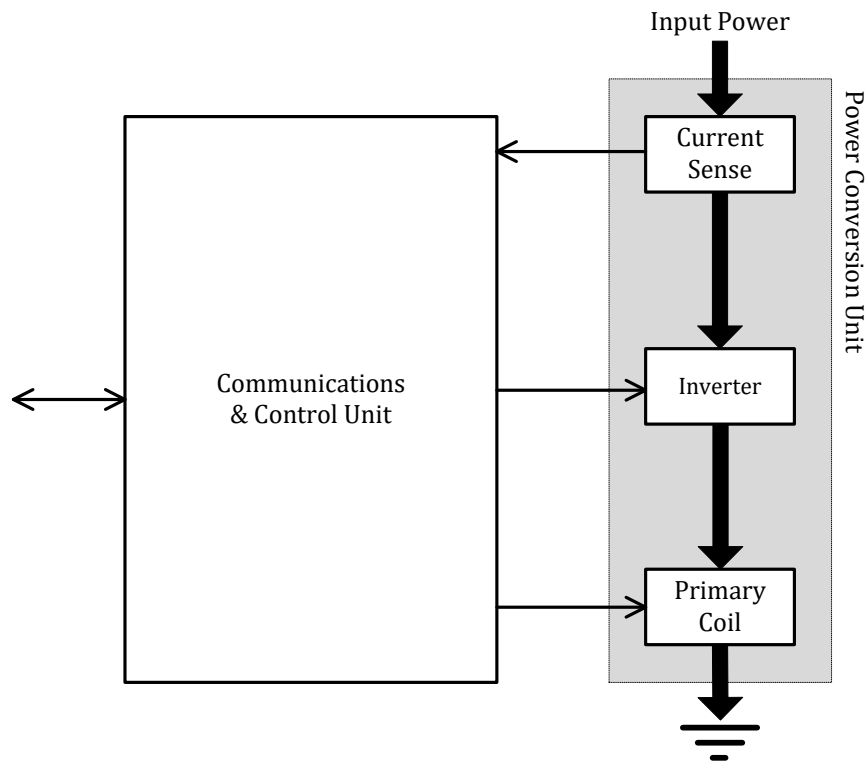

The Power Conversion Unit on the right-hand side of Figure 114 comprises the analog parts of the design. The voltage and current sense monitors the System voltage and current. The inverter converts the DC input to an AC waveform that drives a resonant circuit, which consists of the Primary Coil plus a series capacitor.

The Communications and Control Unit on the left-hand side of Figure 114 comprises the digital logic part of the design. The unit receives and decodes messages from the Power Receiver, executes the relevant power control algorithms and protocols, and drives the input power and frequency of the AC waveform to control the power transfer. The Communications and Control Unit also interfaces with other subsystems of the Base Station, e.g. for user interface purposes.

2.2.30.1 Mechanical details

Power Transmitter design A30 includes one Primary Coil as defined in Section 2.2.30.1.1, Shielding as defined in Section 2.2.30.1.2, and an Interface Surface as defined in Section 2.2.30.1.3.

2.2.30.1.1 Primary Coil

The Primary Coil is of the wire-wound type, and consists of litz wire having 115 strands of 0.08 mm diameter, or equivalent. As shown in Figure 115, a Primary Coil has a racetrack-like shape and consists of a single layer. Table 81 lists the dimensions of a Primary Coil.

Figure 115. Primary Coil of Power Transmitter design A30

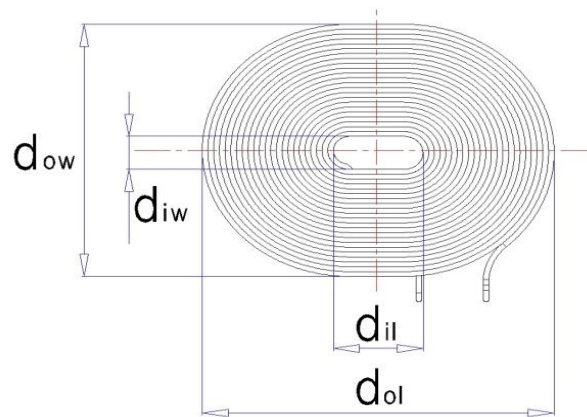

Table 81. Primary Coil parameters of Power Transmitter design A30

Parameter	Symbol	Value
Outer length	d_{ol}	$65.5^{\pm 0.5}$ mm
Inner length	d_{il}	$16.5^{\pm 0.5}$ mm
Outer width	d_{ow}	$57.1^{\pm 0.5}$ mm
Inner width	d_{iw}	$4.5^{\pm 0.5}$ mm
Thickness	d_c	$1.3^{\pm 0.15}$ mm
Number of turns per layer	N	22
Number of layers	–	1

2.2.30.1.2 Shielding

As shown in Figure 116, Shielding protects the Base Station from the magnetic field that is generated in the Primary Coil. The Shielding should be Ni-Zn or Mn-Zn ferrite and should be at least 2.0 mm thick. The Shielding extends to at least 2.5 mm beyond the outer edge of the Primary Coil.

Figure 116. Primary Coil assembly of Power Transmitter design A30

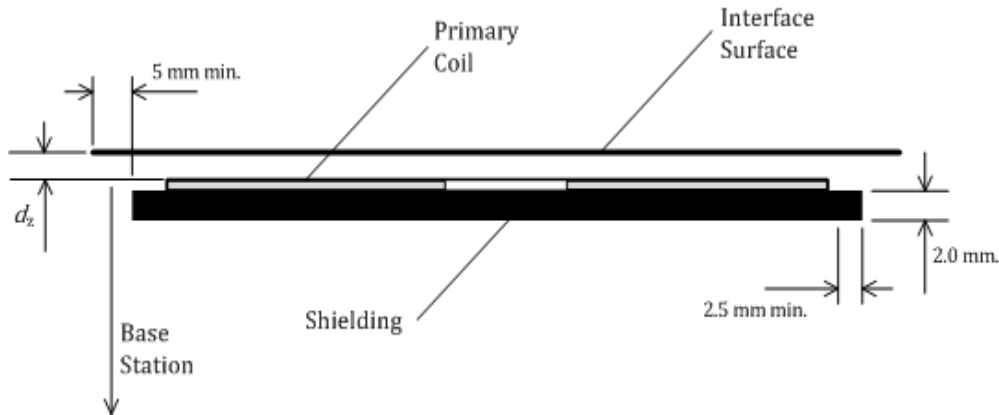

2.2.30.1.3 Interface Surface

As shown in Figure 116, the distance from the Primary Coil to the Interface Surface of the Base Station is $d_z = 5^{\pm 1.0}$ mm, across the top face of the Primary Coil. In addition, the Interface Surface of the Base Station extends at least 5 mm beyond the outer diameter of the Primary Coil.

2.2.30.1.4 Separation between multiple Power transmitters

If the Base Station contains multiple type A30 Power Transmitters, the Primary Coils of any pair of those Power Transmitters shall have a center-to-center distance of at least 80 mm.

2.2.30.2 Electrical details

As shown in Figure 117, Power Transmitter design A30 uses a full-bridge inverter to drive the Primary Coil and a series capacitance. Within the Operating Frequency range Specified below, the assembly of Primary Coil and Shielding has a self inductance $L_p = 24.0^{\pm 10\%}$ μH . The input voltage to the full-bridge inverter is $12^{\pm 5\%}$ V. The value of the series capacitance is $C_p = 100^{\pm 10\%}$ nF.

NOTE Near resonance, the voltage developed across the series capacitance can reach levels up to 100 V pk-pk.

Power Transmitter design A30 uses the Operating Frequency and duty cycle of the Power Signal in order to control the amount of power transferred. For this purpose, The Operating Frequency range is $f_{op} = 110 \dots 205$ kHz, and the duty cycle range of 2...50%.

When a type A30 Power Transmitter first applies a Power Signal (Digital Ping; see *Parts 1 and 2: Interface Definitions*), the Power Transmitter shall use an Operating Frequency of $130^{\pm 10}$ kHz, and a duty cycle of $25^{\pm 15\%}$. If the Power Transmitter does not to receive a Signal Strength Packet from the Power Receiver, the Power Transmitter shall remove the Power Signal as defined in *Parts 1 and 2: Interface Definitions*. The Power Transmitter may re-apply the Power Signal multiple times at consecutively higher duty cycle to the full-bridge inverter within the range specified above, until the Power Transmitter receives a Signal Strength Packet containing an appropriate Signal Strength Value.

Figure 117. Electrical diagram (outline) of Power Transmitter design A30

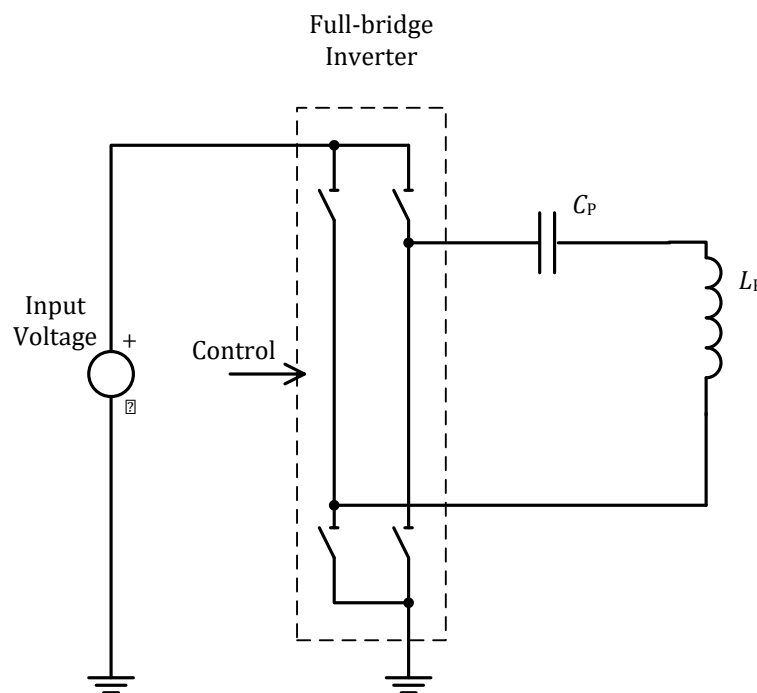

Control of the power transfer shall proceed using the PID algorithm, which is defined in *Parts 1 and 2: Interface Definitions*. The controlled variable $v^{(i)}$ introduced in the definition of that algorithm represents the Operating Frequency to the full-bridge inverter and duty cycle. It is recommended that control of the power occurs primarily by means of adjustments to the Operating Frequency and that duty cycle adjustments are made according to the amount of current. In order to guarantee sufficiently accurate power control, a type A30 Power Transmitter shall determine the amplitude of the Primary Coil current with a resolution of 5 mA or better. Finally, Table 82 and Table 83 provide the value of several parameters, which are used in the PID algorithm.

Table 82. PID parameters for Operating Frequency control

Parameter	Symbol	Value	Unit
Proportional gain	K_p	1	mA^{-1}
Integral gain	K_i	0	$\text{mA}^{-1}\text{ms}^{-1}$
Derivative gain	K_d	0	mA^{-1}ms
Integral term limit	M_I	N.A.	N.A.
PID output limit	M_{PID}	20,000	N.A.
Scaling factor	S_v	1.0	Hz

Table 83. PID parameters for duty cycle control

Parameter	Symbol	Value	Unit
Proportional gain	K_p	1	mA^{-1}
Integral gain	K_i	0	$\text{mA}^{-1}\text{ms}^{-1}$
Derivative gain	K_d	0	mA^{-1}ms
Integral term limit	M_I	N.A.	N.A.
PID output limit	M_{PID}	20,000	N.A.
Scaling factor	S_v	-0.1	°

2.2.31 Power Transmitter design A31

Figure 118 illustrates the functional block diagram of Power Transmitter design A31, which consists of two major functional units, namely a Power Conversion Unit and a Communications and Control Unit.

Figure 118. Functional block diagram of Power Transmitter design A31

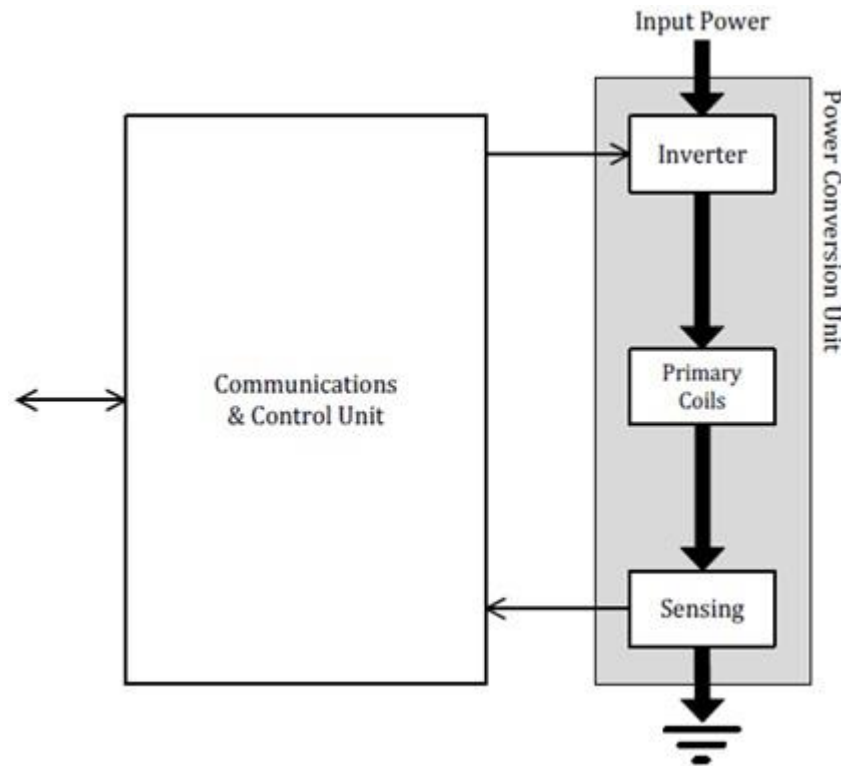

The Power Conversion Unit on the right-hand side of Figure 118 comprises the analog parts of the design. The inverter converts the DC input to an AC waveform that drives a resonant circuit, which consists of the Primary Coil plus a series capacitor. Finally, the voltage and current sense monitors the Primary Coil voltage and current.

The Communications and Control Unit on the left-hand side of Figure 118 comprises the digital logic part of the design. The unit receives and decodes messages from the Power Receiver, executes the relevant power control algorithms and protocols, and drives the input power and frequency of the AC waveform to control the power transfer. The Communications and Control Unit also interfaces with other subsystems of the Base Station, e.g. for user interface purposes.

2.2.31.1 Mechanical details

Power Transmitter design A31 includes one Primary Coil as defined in Section 2.2.31.1.1, Shielding as defined in Section 2.2.31.1.2, and an Interface Surface as defined in Section 2.2.31.1.3.

2.2.31.1.1 Primary Coil

The Primary Coil is of the wire-wound type, and consists of litz wire having 115 strands of 0.08 mm diameter, or equivalent. As shown in Figure 119, a Primary Coil has a racetrack-like shape and consists of a single layer. Table 84 lists the dimensions of a Primary Coil.

Figure 119. Primary Coil of Power Transmitter design A31

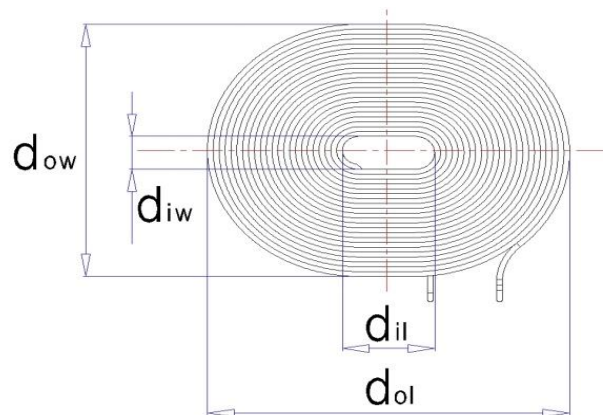

Table 84. Primary Coil parameters of Power Transmitter design A31

Parameter	Symbol	Value
Outer length	d_{ol}	$65.5^{\pm 0.5}$ mm
Inner length	d_{il}	$16.5^{\pm 0.5}$ mm
Outer width	d_{ow}	$57.1^{\pm 0.5}$ mm
Inner width	d_{iw}	$4.5^{\pm 0.5}$ mm
Thickness	d_c	$1.3^{\pm 0.15}$ mm
Number of turns per layer	N	22
Number of layers	–	1

2.2.31.1.2 Shielding

As shown in Figure 120, Shielding protects the Base Station from the magnetic field that is generated in the Primary Coil. The Shielding should be Ni-Zn or Mn-Zn ferrite and should be at least 2.0 mm thick. The Shielding extends to at least 2.5 mm beyond the outer edge of the Primary Coil.

Figure 120. Primary Coil assembly of Power Transmitter design A31

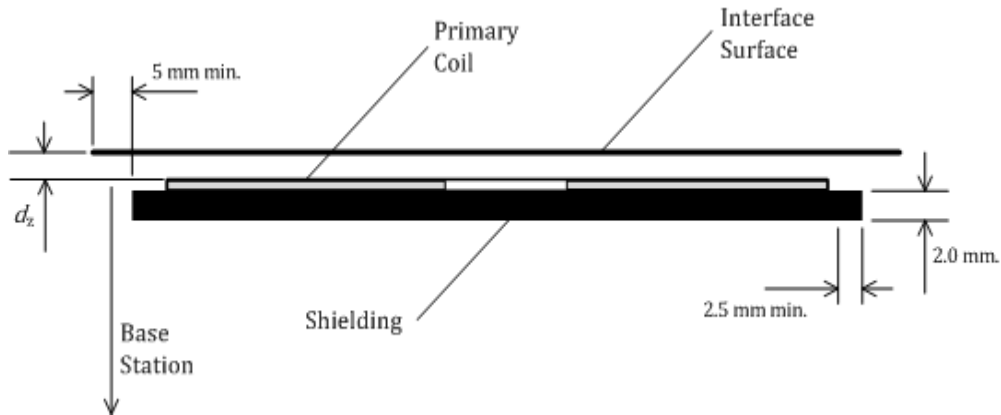

2.2.31.1.3 Interface Surface

As shown in Figure 120, the distance from the Primary Coil to the Interface Surface of the Base Station is $d_z = 3.0^{\pm 0.5}$ mm, across the top face of the Primary Coil. In addition, the Interface Surface of the Base Station extends at least 5.0 mm beyond the outer diameter of the Primary Coil.

2.2.31.1.4 Separation between multiple Power transmitters

If the Base Station contains multiple type A31 Power Transmitters, the Primary Coils of any pair of those Power Transmitters shall have a center-to-center distance of at least 71.0 mm.

2.2.31.2 Electrical details

As shown in Figure 121, Power Transmitter design A31 uses a full-bridge inverter to drive the Primary Coil and a series capacitance. Within the Operating Frequency range specified below, the assembly of Primary Coil and Shielding has a self inductance $L_P = 24^{\pm 10\%}$ μH . The input voltage to the full-bridge inverter is $12^{\pm 5\%}$ V. The value of the series capacitance is $C_P = 148^{\pm 5\%}$ nF.

NOTE Near resonance, the voltage developed across the series capacitance can reach levels up to 100 V pk-pk.

Power Transmitter design A31 uses the Operating Frequency and duty cycle of the Power Signal in order to control the amount of power transferred. For this purpose, the Operating Frequency is $f_{op} = 87 \dots 110$ kHz and the duty cycle range of 2...50%.

When a type A31 Power Transmitter first applies a Power Signal (Digital Ping; see *Parts 1 and 2: Interface Definitions*), the Power Transmitter shall use an Operating Frequency of $98^{\pm 10.0}$ kHz, and a duty cycle of $25^{\pm 10.0\%}$. If the Power Transmitter does not receive a Signal Strength Packet from the Power Receiver, the Power Transmitter shall remove the Power Signal as defined in *Parts 1 and 2: Interface Definitions*. The Power Transmitter may reapply the Power Signal multiple times at consecutively higher duty cycles to the full bridge inverter within the range specified above, until the Power Transmitter receives a Signal Strength Packet containing an appropriate Signal Strength Value.

Figure 121. Electrical diagram (outline) of Power Transmitter design A31

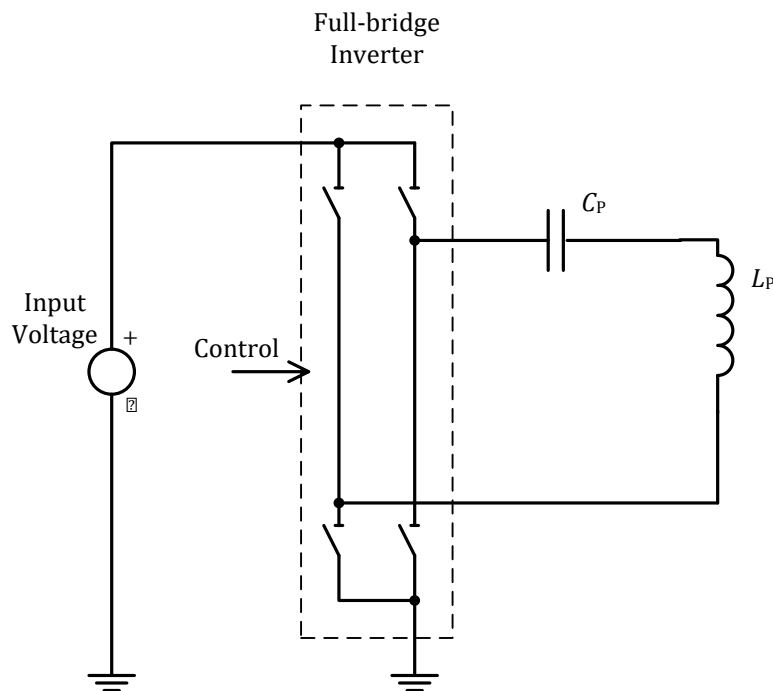

Control of the power transfer shall proceed using the PID algorithm, which is defined in *Parts 1 and 2: Interface Definitions*. The controlled variable $v^{(i)}$ introduced in the definition of that algorithm represents the Operating Frequency as well as the duty cycle to the full-bridge inverter. It is recommended that control of the power occurs primarily by means of adjustments to the Operating Frequency, and that duty cycle adjustments are made according to the amount of current. In order to guarantee sufficiently accurate power control, a type A31 Power Transmitter shall determine the amplitude of the Primary Coil current with a resolution of 5 mA or better. Finally, Table 85 and Table 86 provide the values of several parameters, which are used in the PID algorithm.

Table 85. PID parameters for Operating Frequency control

Parameter	Symbol	Value	Unit
Proportional gain	K_p	1	mA^{-1}
Integral gain	K_i	0	$\text{mA}^{-1}\text{ms}^{-1}$
Derivative gain	K_d	0	mA^{-1}ms
Integral term limit	M_I	N.A.	N.A.
PID output limit	M_{PID}	20,000	N.A.
Scaling factor	S_v	1.0	Hz

Table 86. PID parameters for duty control

Parameter	Symbol	Value	Unit
Proportional gain	K_p	1	mA^{-1}
Integral gain	K_i	0	$\text{mA}^{-1}\text{ms}^{-1}$
Derivative gain	K_d	0	mA^{-1}ms
Integral term limit	M_I	N.A.	N.A.
PID output limit	M_{PID}	20,000	N.A.
Scaling factor	S_v	-0.1	°

2.2.32 Power Transmitter design A32

Figure 122 illustrates the functional block diagram of Power Transmitter design A32, which consists of two major functional units, namely a Power Conversion Unit and a Communications and Control Unit.

Figure 122. Functional block diagram of Power Transmitter design A32

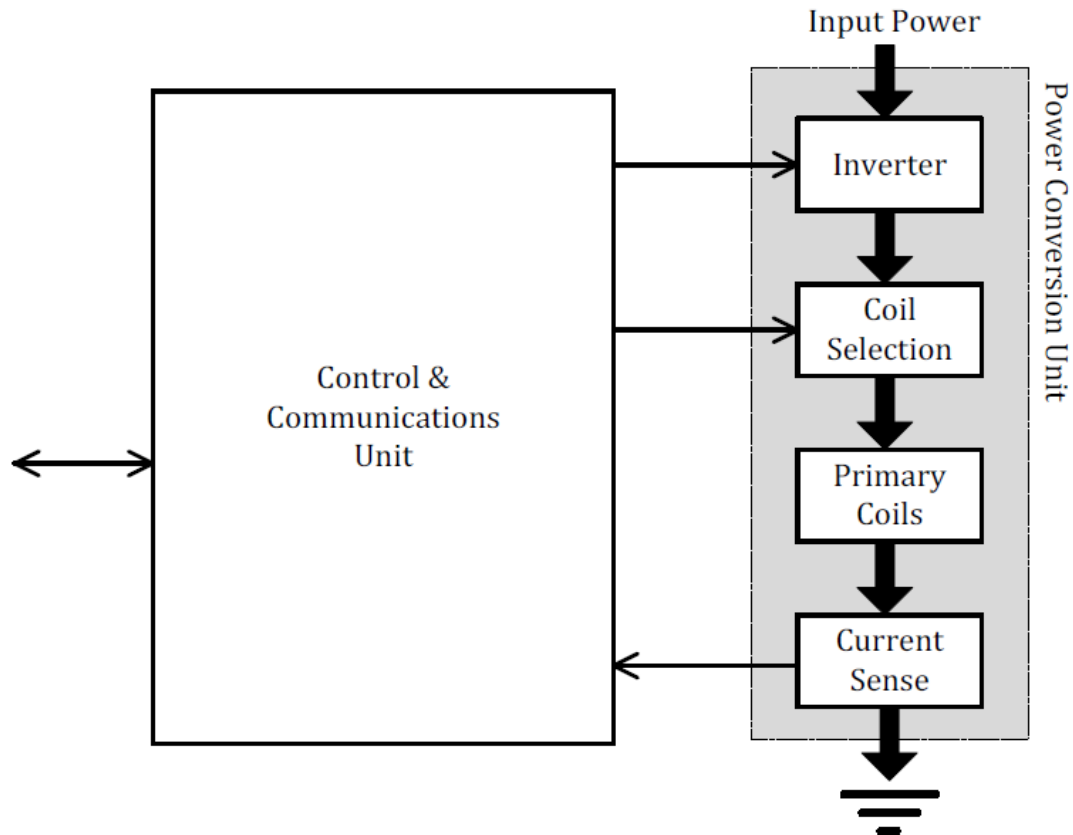

The Power Conversion Unit on the right-hand side of Figure 122 comprises the analog parts of the design. The inverter converts the DC input to an AC waveform that drives a resonant circuit, which consists of the selected Primary Coil plus a series capacitor. The selected Primary Coil is one from a linear array of partially overlapping Primary Coils, as appropriate for the position of the Power Receiver relative to the Primary Coils. Selection of the Primary Coil proceeds by the Power Transmitter attempting to establish communication with a Power Receiver using any of the Primary Coils. Note that the array may consist of a single Primary Coil only, in which case the selection is trivial. Finally, the current sense monitors the Primary Coil current.

The Communications and Control Unit on the left-hand side of Figure 122 comprises the digital logic part of the design. This unit receives and decodes messages from the Power Receiver, configures the Coil Selection block to connect the appropriate Primary Coil, executes the relevant power control algorithms and protocols, and drives the frequency of the AC waveform to control the power transfer. The Communications and Control Unit also interfaces with other subsystems of the Base Station, e.g. for user interface purposes.

2.2.32.1 Mechanical details

Power Transmitter design A32 includes one Primary Coil as defined in Section 2.2.32.1.1, Shielding as defined in Section 2.2.32.1.2, and an Interface Surface as defined in Section 2.2.32.1.3.

2.2.32.1.1 Primary coil

The Primary Coil consists of at least one PCB coil. Figure 115 shows a view of a single Primary Coil. Table 87 lists the dimensions of the Primary Coil.

Figure 123. Primary Coil of Power Transmitter design A32

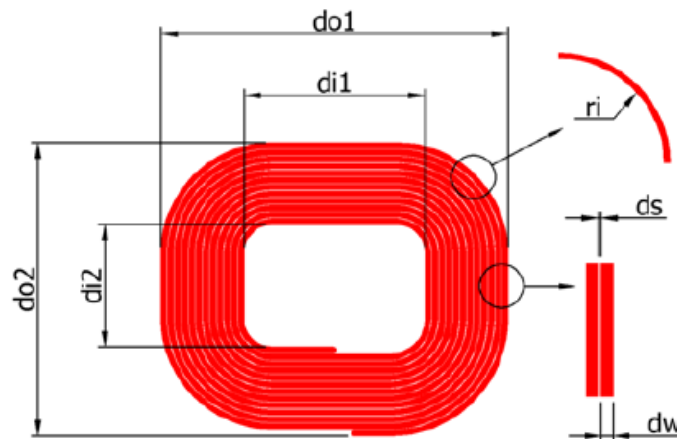

Table 87. Primary Coil parameters of Power Transmitter design A32

Parameter	Symbol	Value
Outer length	d_{o1}	53.4 \pm 0.7 mm
Inner length	d_{i1}	27.5 \pm 0.7 mm
Outer width	d_{o2}	45.8 \pm 0.7 mm
Inner width	d_{i2}	19.5 \pm 0.75 mm
4- layer PCB		
Track width	d_w	0.82 \pm 0.2 mm
Track width plus spacing	d_w+d_s	1.08 \pm 0.2 mm
Corner rounding*	r_i	16.7 \pm 1.0 mm
Number of turns	N	12 \pm 0.25
5...8 layer PCB		
Track width	d_w	0.55 \pm 0.15 mm
Track width plus spacing	d_w+d_s	1.1 \pm 0.15 mm
Corner rounding*	r_i	13.1 \pm 1.31 mm
Number of turns	N	12 \pm 0.25

Power Transmitter design A32 contains at least one Primary Coil. Odd numbered coils are placed alongside each other with a displacement of d_{h2} between their centers. Even numbered coils are placed orthogonal to the odd numbered coils with a displacement of d_{h1} mm between their centers. See Figure 124.

Figure 124. Primary Coils of Power Transmitter design A32

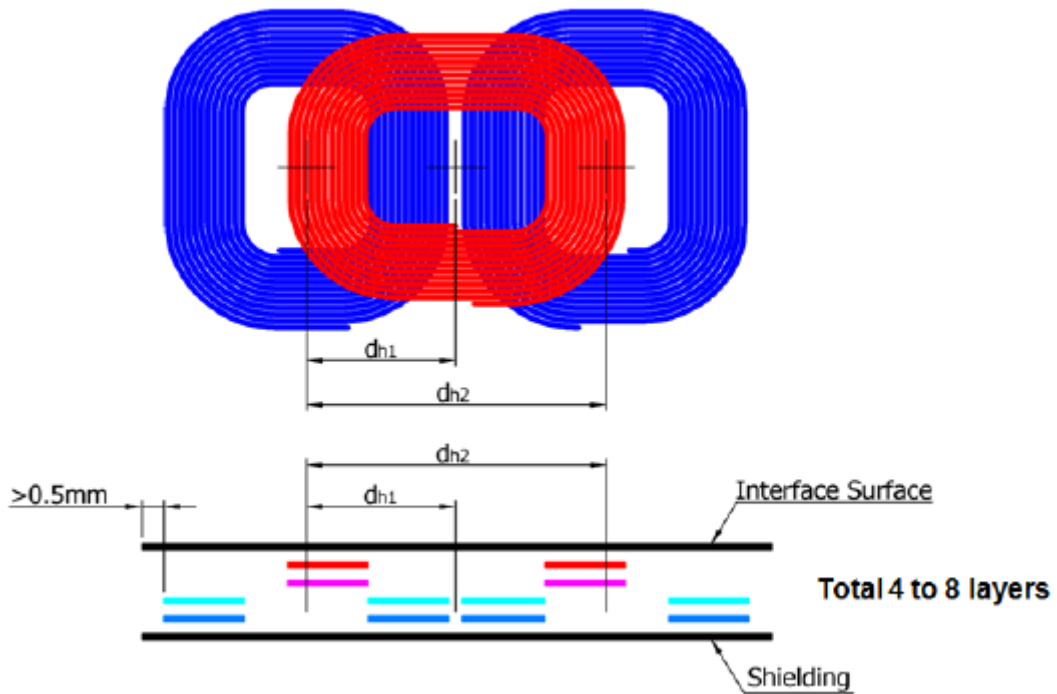

Figure 125. Primary Coils of Power Transmitter design A32

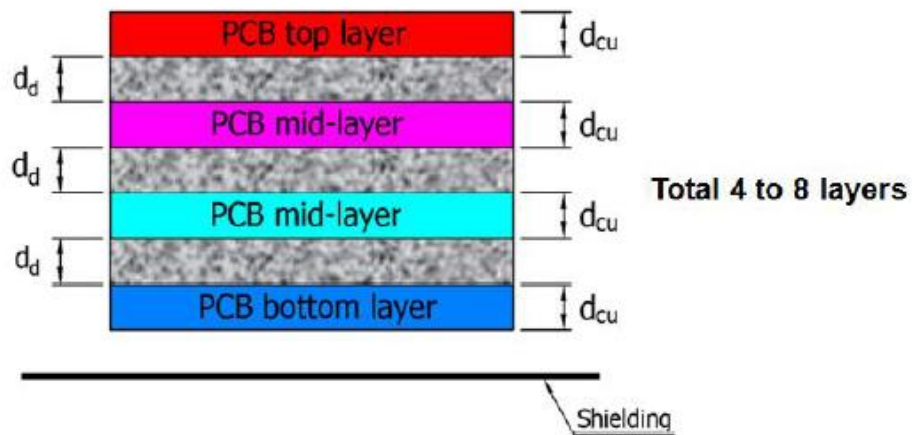

Table 88. Primary Coil parameters of Power Transmitter design A32

Parameter	Symbol	Value
4- layer PCB		
Center-to-center distance	d_{h1}	23.8 \pm 1.0 mm
Center-to-center distance	d_{h2}	47.52 \pm 2.0 mm
PCB copper thickness	d_{Cu}	0.105 \pm 0.015 mm
Dielectric thickness	d_d	0.375 \pm 0.063 mm
5...8 layer PCB		
Center-to-center distance	d_{h1}	23.76 \pm 1.5 mm
Center-to-center distance	d_{h2}	47.52 \pm 3.0 mm
PCB copper thickness	d_{Cu}	0.105 \pm 0.0161 mm
Dielectric thickness	d_d	0.125 \pm 0.0254 mm

2.2.32.1.2 Shielding

As shown in Figure 126, Shielding protects the Base Station from the magnetic field that is generated in the Primary Coil. The Shielding should be Ni-Zn or Mn-Zn ferrite and should be at least 0.5 mm thick. The Shielding extends to at least the outer dimensions of the Primary Coils, and is placed below the Primary Coil at a distance of at most $d_s = 1.0$ mm.

Figure 126. Primary Coil assembly of Power Transmitter design A32

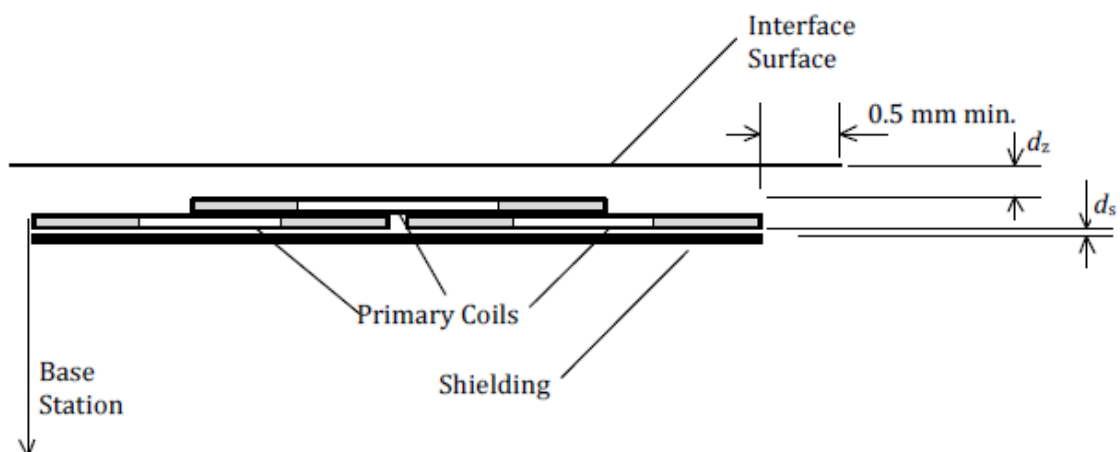

2.2.32.1.3 Interface Surface

As shown in Figure 126, the distance from the Primary Coil to the Interface Surface of the Base Station is $d_z=2.75^{\pm 1}$ mm, across the top face of the Primary Coil. In addition, the Interface Surface of the Base Station extends at least 0.5 mm beyond the outer dimensions of the Primary Coils.

2.2.32.1.4 Separation between multiple Power transmitters

If the Base Station contains multiple type A32 Power Transmitters, the Primary Coils of any pair of those Power Transmitters shall have a center-to-center distance of at least $49.2^{\pm 4}$ mm.

2.2.32.2 Electrical details

As shown in Figure 117, Power Transmitter design A32 uses a full-bridge inverter to drive an individual Primary Coil and a series capacitance. Within the Operating Frequency range Specified below, the assembly of Primary Coil and Shielding has a self-inductance $L_p = 11.5^{\pm 10\%}$ μH for coils closest to the interface surface, and inductance $L_p = 12.5^{\pm 10\%}$ for coils furthest from the Interface Surface. The value of inductances L_1 and L_2 is $1^{\pm 20\%}$ μH . The value of the total series capacitance is $1/C_{\text{ser}1} + 1/C_{\text{ser}2} = 1/200^{\pm 10\%}$ 1/nF. The value of the parallel capacitance is $C_{\text{par}} = 400^{\pm 10\%}$ nF.

NOTE Near resonance, the voltage developed across the series capacitance can reach levels exceeding 100 V pk-pk. Power

Power Transmitter design A32 uses the input voltage of the inverter to control the amount of power that is transferred. For this purpose, the input voltage has a range of 1...12 V, with a resolution of 10 mV or better. The Operating Frequency is $f_{\text{op}} = 105 \dots 115$ kHz, with a duty cycle of 50%.

When a type A32 Power Transmitter first applies a Power Signal (Digital Ping; see *Parts 1 and 2: Interface Definitions*), it shall use an initial voltage of $3.5^{\pm 0.5}$ V for a bottom Primary Coil, and $3.0^{\pm 0.5}$ V for a top Primary Coil, and a recommended Operating Frequency of 110 kHz.

Figure 127. Electrical diagram (outline) of Power Transmitter design A32

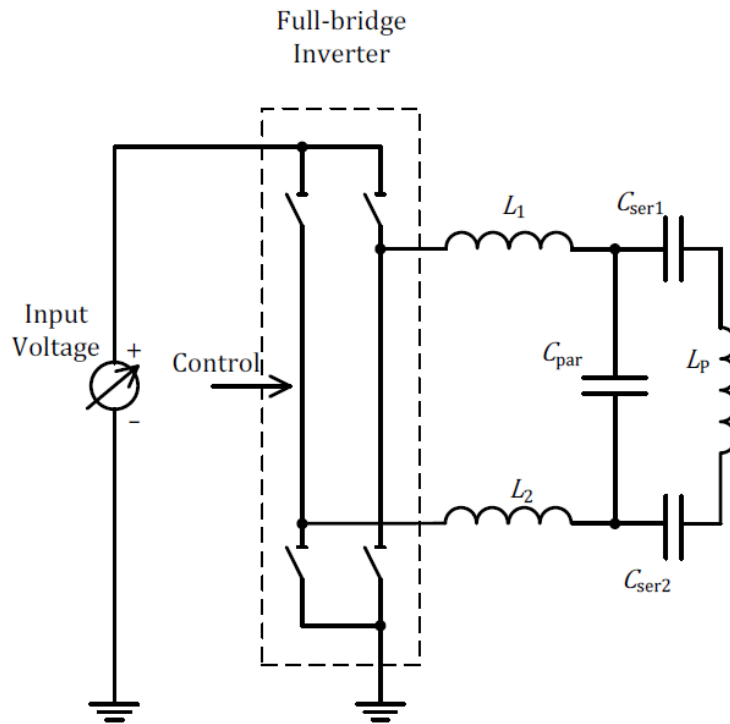

Control of the power transfer shall proceed using the PID algorithm, which is defined in *Parts 1 and 2: Interface Definitions*. The controlled variable $v^{(i)}$ introduced in the definition of that algorithm represents the input voltage to the inverter. In order to guarantee sufficiently accurate power control, a type A32 Power Transmitter shall determine the amplitude of the Primary Cell current—which is equal to the Primary Coil current—with a resolution of 7 mA or better. Finally, Table 89 provides the values of several parameters, which are used in the PID algorithm.

Table 89. PID parameters for voltage control

Parameter	Symbol	Value	Unit
Proportional gain	K_p	0.03	mA-1
Integral gain	K_i	0.01	mA-1ms-1
Derivative gain	K_d	0	mA-1ms
Integral term limit	M_I	3,000	N.A.
PID output limit	M_{PID}	20,000	N.A.
Scaling factor	S_v	-1	mV

2.2.33 Power Transmitter design A33

Power Transmitter design A33 enables Free Positioning of Power Receiver. Figure 128 illustrates the functional block diagram of this Power Transmitter design A33, which consists of two major functional units, namely a Power Conversion Unit and a Communications and Control Unit.

Figure 128. Functional block diagram of Power Transmitter design A33

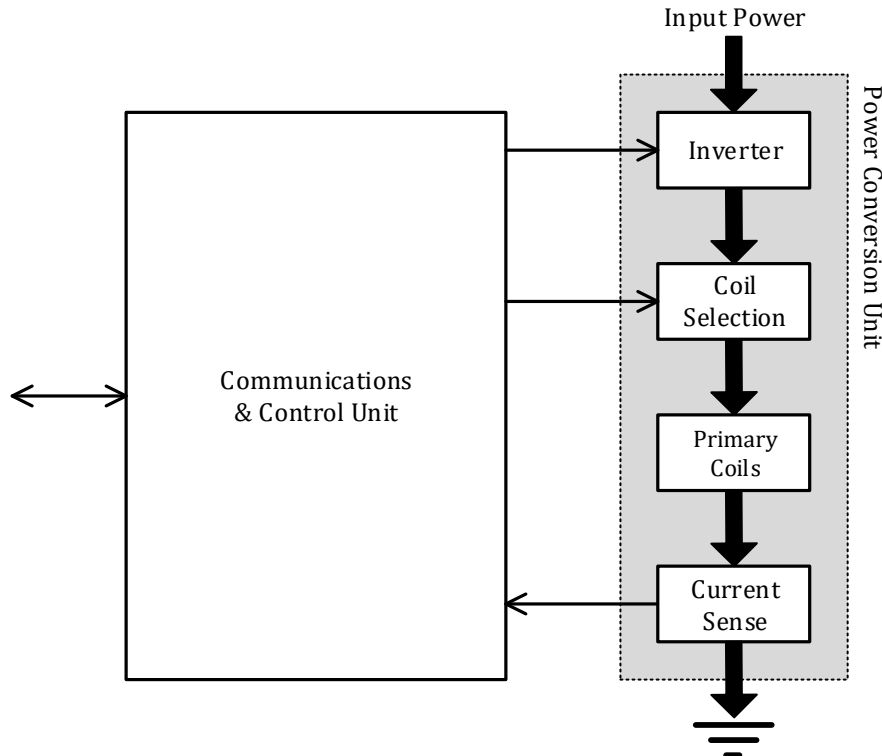

The Power Conversion Unit on the right-hand side of Figure 128 comprises the analog parts of the design. The inverter converts the DC input to an AC waveform that drives a resonant circuit, which consists of the selected Primary Coil plus a series capacitor. The selected Primary Coil is one from a linear array of partially overlapping Primary Coils, as appropriate for the position of the Power Receiver relative to the Primary Coils. Selection of the Primary Coil proceeds by the Power Transmitter attempting to establish communication with a Power Receiver using any of the Primary Coils. Note that the array may consist of a single Primary Coil only, in which case the selection is trivial. Finally, the current sense monitors the Primary Coil current.

The Communications and Control Unit on the left-hand side of Figure 128 comprises the digital logic part of the design. This unit receives and decodes messages from the Power Receiver, configures the Coil Selection block to connect the appropriate Primary Coil, executes the relevant power control algorithms and protocols, and drives the frequency of the AC waveform to control the power transfer. The Communications and Control Unit also interfaces with other subsystems of the Base Station, e.g. for user interface purposes.

2.2.33.1 Mechanical details

Power Transmitter design A33 includes one or more Primary Coils as defined in Section 2.2.33.1.1, Shielding as defined in Section 2.2.33.1.2, an Interface Surface as defined in Section 2.2.33.1.3.

2.2.33.1.1 Primary coil

The Primary Coil consists of at least one PCB coil. Figure 129 shows a view of a single Primary Coil. Table 90 lists the dimensions of the Primary Coil.

Figure 129. Primary Coil of Power Transmitter design A33

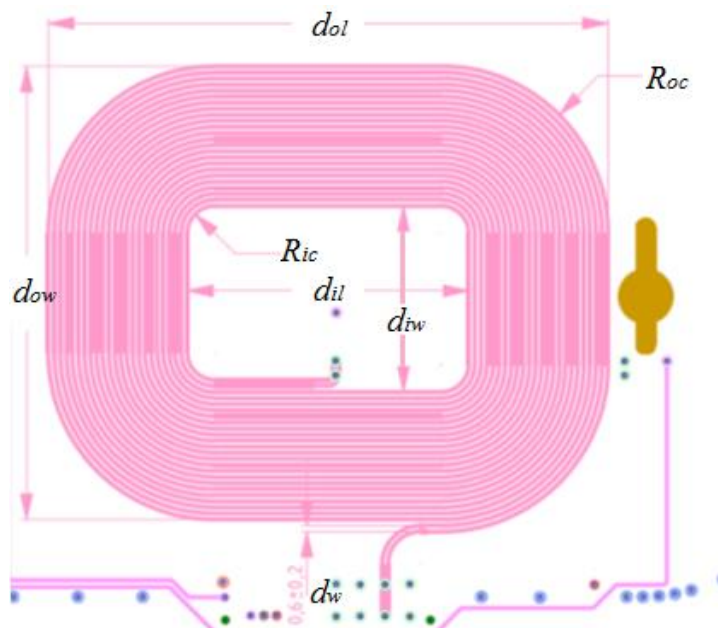

Table 90. Primary Coil parameters of Power Transmitter design A33

Parameter	Symbol	Value
Outer length	d_{ol}	$55.5^{\pm 0.2}$ mm
Inner length	d_{il}	$27.9^{\pm 0.2}$ mm
Outer width	d_{ow}	$44.8^{\pm 0.2}$ mm
Inner width	d_{iw}	$18.4^{\pm 0.2}$ mm
Track width	d_w	$0.6^{\pm 0.2}$ mm
Outer Corner rounding*	R_{oc}	$16.5^{\pm 0.2}$ mm
Inner Corner rounding**	R_{ic}	$2.7^{\pm 0.2}$ mm
Number of turns	N	12

* outermost winding only

** innermost winding only

Power Transmitter design A33 contains at least one Primary Coil. Odd numbered coils are placed alongside each other with a displacement of d_{oo} between their centers. Even numbered coils are placed orthogonal to the odd numbered coils with a displacement of d_{oe} between their centers. See Figure 130 and Figure 131. Table 91 lists the dimensions of the Primary Coils.

Figure 130. Three Primary Coils of Power Transmitter design A33

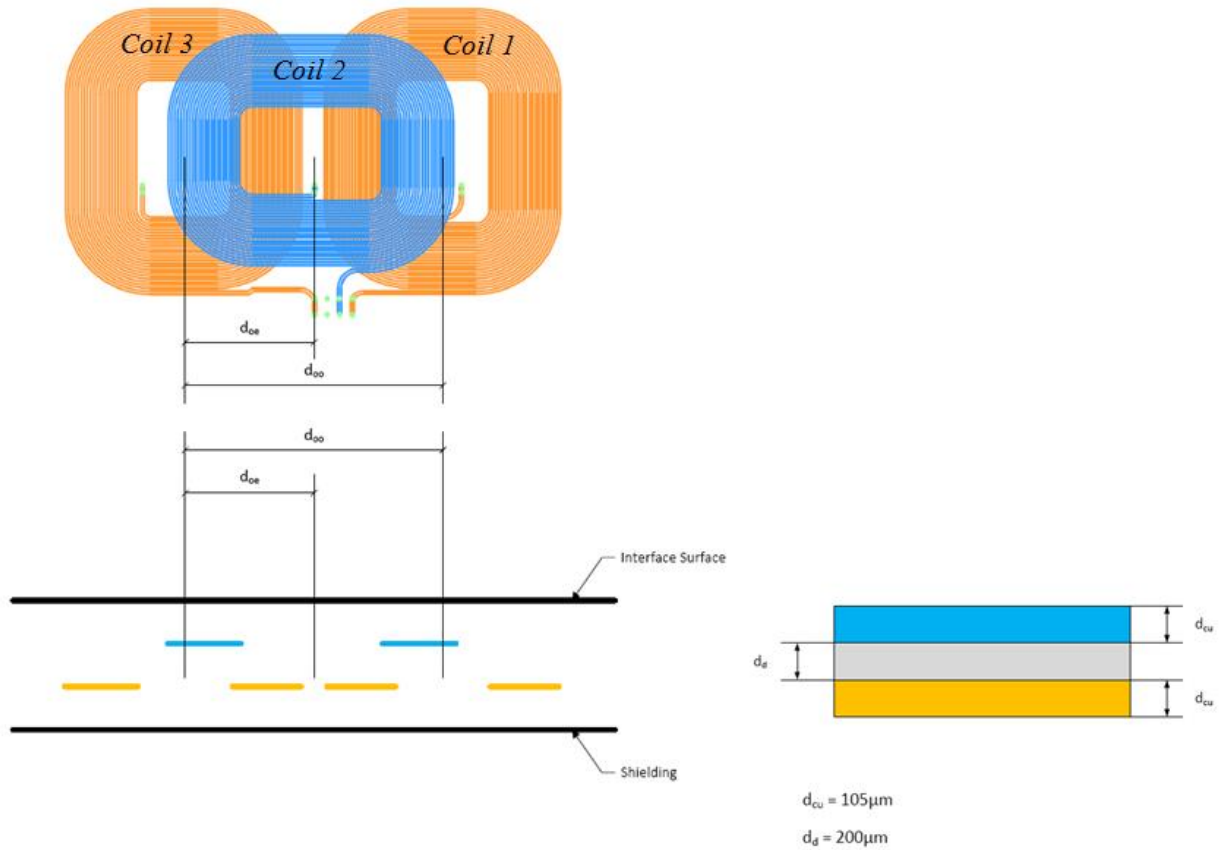

Figure 131. Four Primary Coils of Power Transmitter design A33

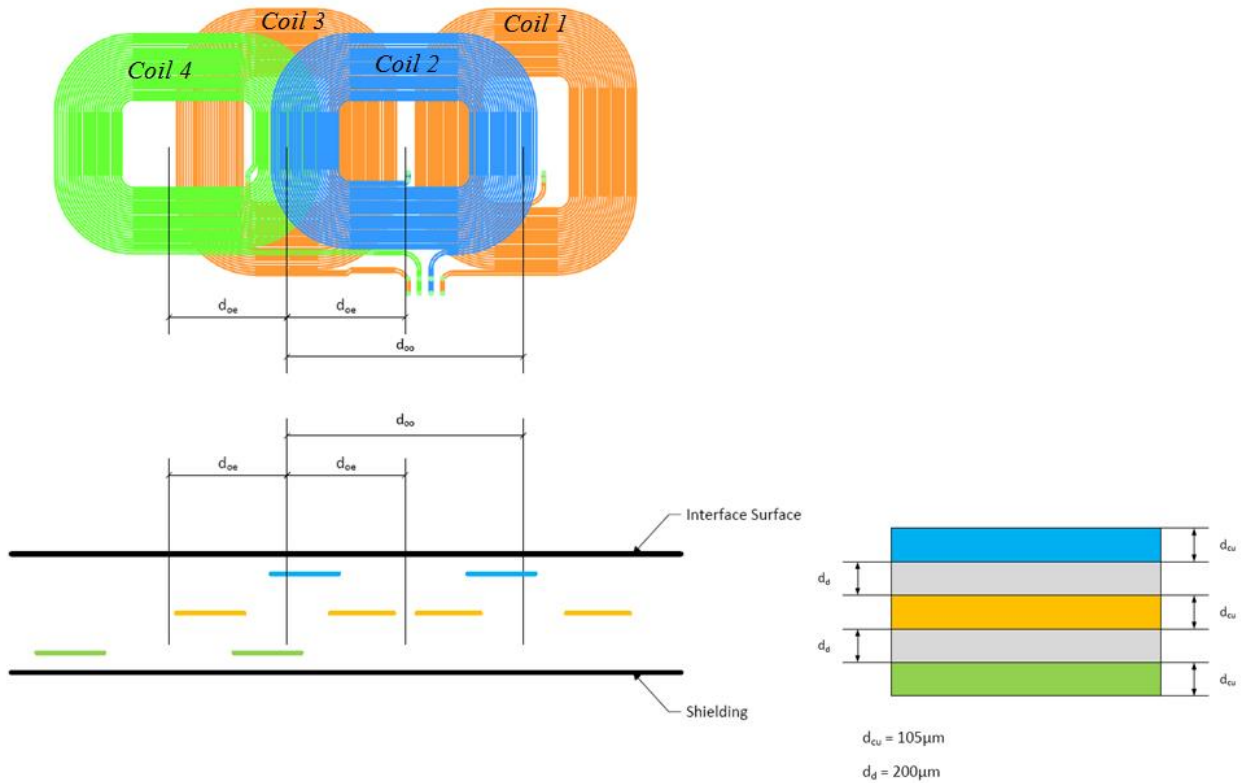
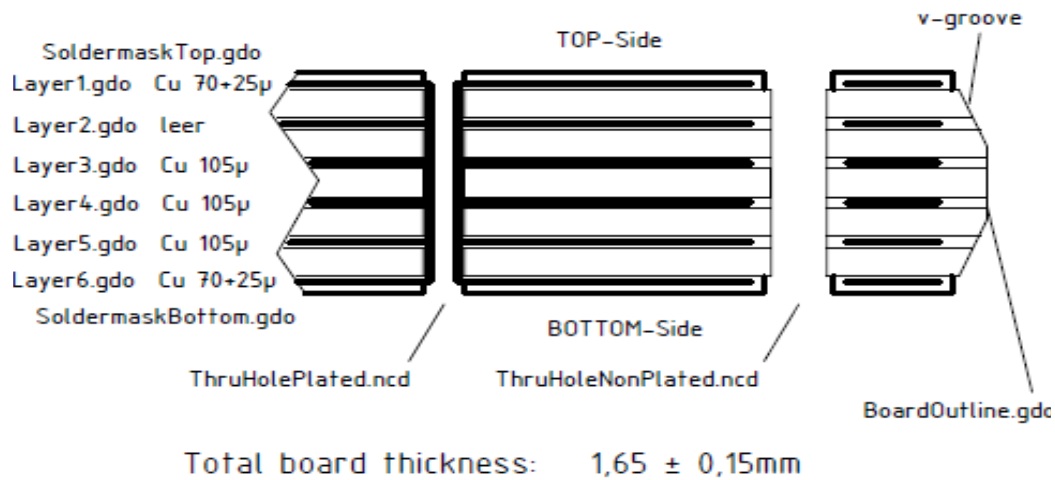

Table 91. Primary Coil parameters of Power Transmitter design A33

Parameter	Symbol	Value
Center-to-center distance	d_{oo}	$49.2^{\pm 0.2}$ mm
Center-to-center distance	d_{oe}	$24.6^{\pm 0.2}$ mm
PCB copper thickness	d_{cu}	105 μm
Dielectric thickness	d_d	200 μm

Figure 132 shows the layered structure of the Primary Coils array. Note: 1 coil configuration uses 1 metal layer, 2 and 3 coils configuration uses 2 metal layers, 4 coils and more coils configuration use 3 metal layers.

Figure 132. Layered structure of the Primary Coils of Power Transmitter design A33



2.2.33.1.2 Shielding

As shown in Figure 133, Shielding protects the Base Station from the magnetic field that is generated in the Primary Coil. The Shielding should be Ni-Zn or Mn-Zn ferrite and should be at least 0.5 mm thick. The Shielding extends to at least the outer dimensions of the Primary Coils, and is placed below the Primary Coil at a distance of at most $d_s = 1.0$ mm.

Figure 133. Primary Coil assembly of Power Transmitter design A33

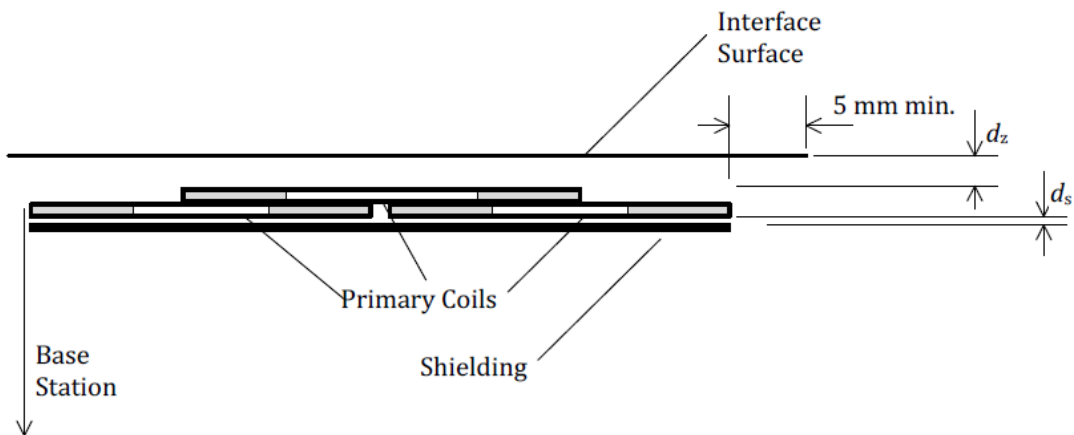

2.2.33.1.3 Interface Surface

As shown in Figure 133, the distance from the Primary Coil to the Interface Surface of the Base Station is $d_z = 3^{\pm 1}$ mm, across the top face of the Primary Coil. In the case of a single Primary Coil, the distance from the Primary Coil to the Interface Surface of the Base Station is $d_z = 4.5^{\pm 1}$ mm, across the top face of the Primary Coil. In addition, the Interface Surface of the Base Station extends at least 5 mm beyond the outer dimensions of the Primary Coils.

2.2.33.1.4 Inter coil separation

If the Base Station contains multiple type A33 Power Transmitters, the Primary Coils of any pair of those Power Transmitters shall have a center-to-center distance of at least $49.2^{\pm 4}$ mm.

2.2.33.2 Electrical details

As shown in Figure 134, Power Transmitter design A33 uses a full-bridge inverter to drive an individual Primary Coil and a series capacitance. Within the Operating Frequency range specified below, the assembly of Primary Coils and Shielding has a self inductance $L_p = 11.5^{\pm 10\%}$ μ H for coils closest to the Interface Surface and inductance $L_p = 12.5^{\pm 10\%}$ μ H for coils furthest from the Interface Surface. The value of inductances L_1 and L_2 is $1^{\pm 20\%}$ μ H. The value of the total series capacitance is $1/C_{ser1} + 1/C_{ser2} = 1/200^{\pm 10\%}$ 1/nF, where the individual series capacitances may have any value less than the sum. The value of the parallel capacitance is $C_{par} = 400^{\pm 10\%}$ nF.

NOTE Near resonance, the voltage developed across the series capacitance can reach levels exceeding 100 V pk-pk.

Power Transmitter design A33 uses the input voltage of the inverter to control the amount of power that is transferred. For this purpose, the input voltage has a range of 1...9V, with a resolution of 10mV or better. The Operating Frequency is $f_{op} = 120...130$ kHz, with a duty cycle of 50%.

When a type A33 Power Transmitter first applies a Power Signal (Digital Ping; see *Parts 1 and 2: Interface Definitions*), it shall use an initial voltage of $4^{\pm 5\%}$ V, and a recommended Operating Frequency of 125 kHz.

Control of the power transfer shall proceed using the PID algorithm, which is defined in *Parts 1 and 2: Interface Definitions*. The controlled variable $v^{(i)}$ introduced in the definition of that algorithm represents the input voltage to the inverter. In order to guarantee sufficiently accurate power control, a type A33 Power Transmitter shall determine the amplitude of the Primary Cell current—which is equal to the Primary Coil current—with a resolution of 7 mA or better. Finally, Table 92 provides the values of several parameters, which are used in the PID algorithm.

Figure 134. Electrical diagram (outline) of Power Transmitter design A33

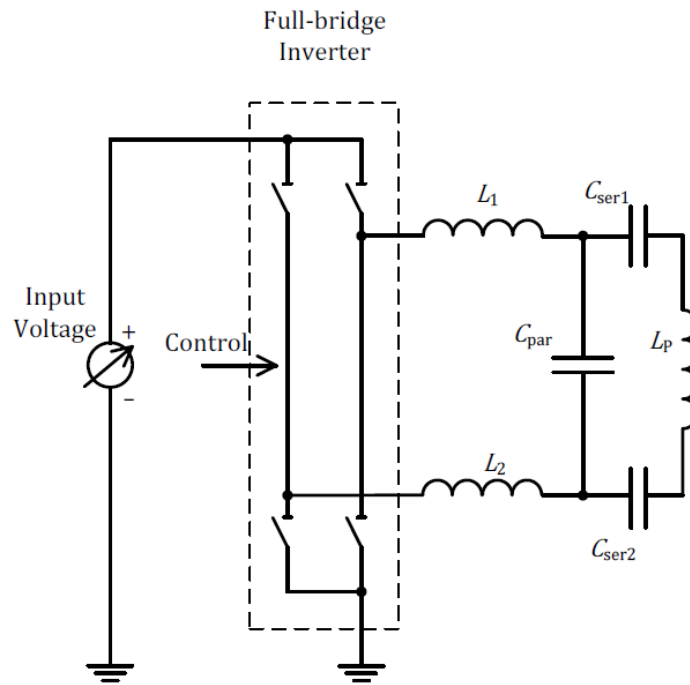

Table 92. PID parameters for voltage control

Parameter	Symbol	Value	Unit
Proportional gain	K_p	0.03	mA^{-1}
Integral gain	K_i	0.01	$\text{mA}^{-1}\text{ms}^{-1}$
Derivative gain	K_d	0	mA^{-1}ms
Integral term limit	M_I	3,000	N.A.
PID output limit	M_{PID}	20,000	N.A.
Scaling factor	S_v	-1	mV

2.2.34 Power Transmitter design A34

Figure 135 illustrates the functional block diagram of Power Transmitter design A34, which consists of two major functional units, namely a Power Conversion Unit and a Communications and Control Unit.

Figure 135. Functional block diagram of Power Transmitter design A34

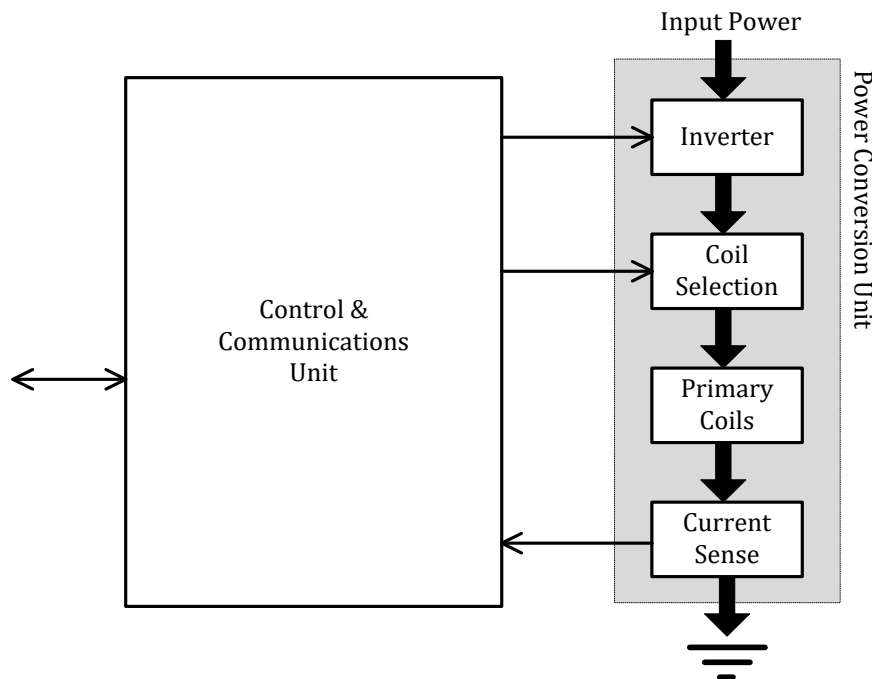

The Power Conversion Unit on the right-hand side of Figure 135 comprises the analog parts of the design. The inverter converts the DC input to an AC waveform that drives a resonant circuit, which consists of the selected Primary Coil plus a series capacitor. The selected Primary Coil is one from a linear array of partially overlapping Primary Coils, as appropriate for the position of the Power Receiver relative to the Primary Coils. Selection of the Primary Coil proceeds by the Power Transmitter attempting to establish communication with a Power Receiver using any of the Primary Coils. Note that the array may consist of a single Primary Coil only, in which case the selection is trivial. Finally, the current sense monitors the Primary Coil current.

The Communications and Control Unit on the left-hand side of Figure 135 comprises the digital logic part of the design. This unit receives and decodes messages from the Power Receiver, configures the Coil Selection block to connect the appropriate Primary Coil, executes the relevant power control algorithms and protocols, and drives the frequency of the AC waveform to control the power transfer. The Communications and Control Unit also interfaces with other subsystems of the Base Station, e.g. for user interface purposes.

2.2.34.1 Mechanical details

Power Transmitter design A34 includes one or more Primary Coils as defined in Section 2.2.34.1.1, Shielding as defined in Section 2.2.34.1.2, an Interface Surface as defined in Section 2.2.34.1.3.

2.2.34.1.1 Primary Coil

The Primary Coil is of the wire-wound type, and consists of no. 17 AWG (1.15 mm diameter) type 2 litz wire having 105 strands of no. 40 AWG (0.08 mm diameter), or equivalent. As shown in Figure 136, the Primary Coil has a rectangular shape and consists of a single layer. Table 93 lists the dimensions of the Primary Coil.

Figure 136. Primary Coil of Power Transmitter design A34

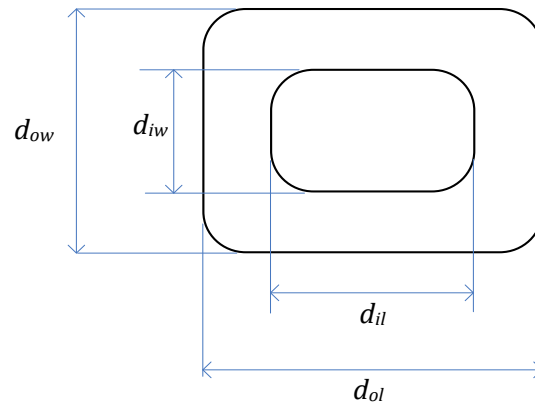
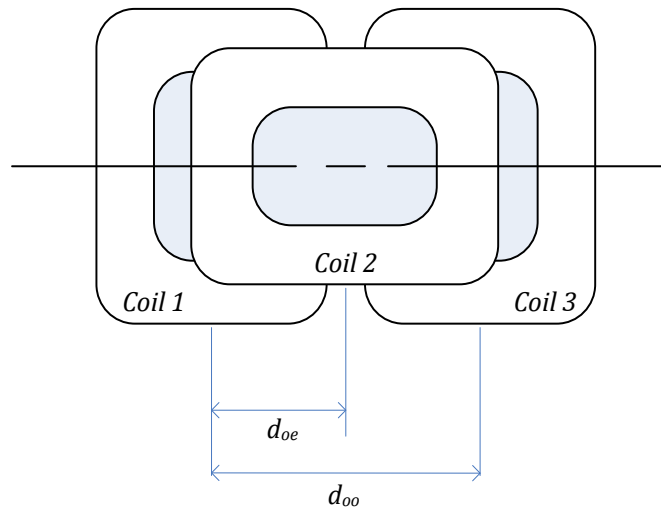

Table 93. Primary Coil parameters of Power Transmitter design A34

Parameter	Symbol	Value
Outer length	d_{ol}	$53.2^{\pm 0.5}$ mm
Inner length	d_{il}	$27.5^{\pm 0.5}$ mm
Outer width	d_{ow}	$45.2^{\pm 0.5}$ mm
Inner width	d_{iw}	$19.5^{\pm 0.5}$ mm
Thickness	d_c	$1.5^{\pm 0.5}$ mm
Number of turns per layer	N	12 turns
Number of layers	-	1

Power Transmitter design A34 contains at least one Primary Coil. Odd numbered coils are placed alongside each other with a displacement of $d_{oo} = 49.2^{\pm 4}$ mm between their centers. Even numbered coils are placed orthogonal to the odd numbered coils with a displacement of $d_{oe} = 24.6^{\pm 2}$ mm between their centers. See Figure 137.

Figure 137. Primary Coils of Power Transmitter design A34



2.2.34.1.2 Shielding

As shown in Figure 138, Shielding protects the Base Station from the magnetic field that is generated in the Primary Coil. The Shielding should be Ni-Zn or Mn-Zn ferrite and should be at least 0.5 mm thick. The Shielding extends to at least the outer dimensions of the Primary Coils, and is placed below the Primary Coil at a distance of at most $d_s = 1.0$ mm.

Figure 138. Primary Coil assembly of Power Transmitter design A34

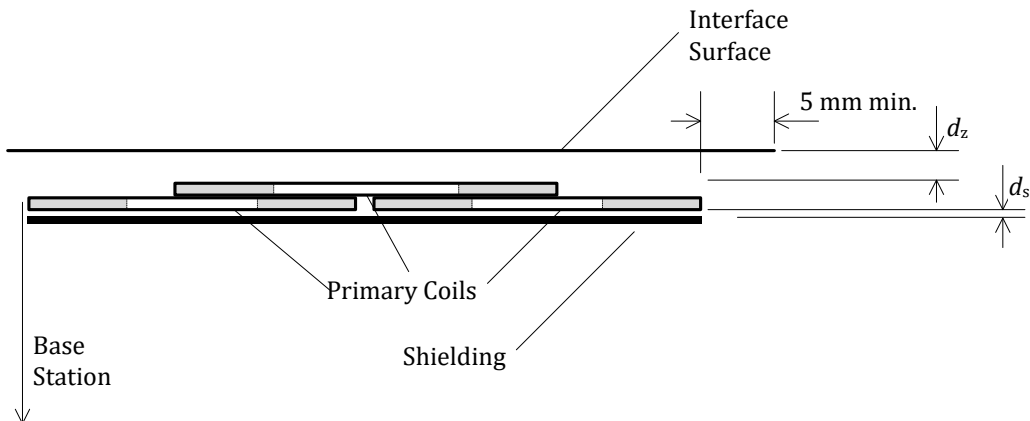

2.2.34.1.3 Interface Surface

As shown in Figure 138, the distance from the Primary Coil to the Interface Surface of the Base Station is $d_z = 3^{\pm 1}$ mm, across the top face of the Primary Coil. In the case of a single Primary Coil, the distance from the Primary Coil to the Interface Surface of the Base Station is $d_z = 4.5^{\pm 1}$ mm, across the top face of the Primary Coil. In addition, the Interface Surface of the Base Station extends at least 5 mm beyond the outer dimensions of the Primary Coils.

2.2.34.1.4 Inter coil separation

If the Base Station contains multiple type A34 Power Transmitters, the Primary Coils of any pair of those Power Transmitters shall have a center-to-center distance of at least $49.2^{\pm 4}$ mm.

2.2.34.2 Electrical details

As shown in Figure 139, Power Transmitter design A34 uses a half-bridge inverter to drive an individual Primary Coil and a series capacitance. Within the Operating Frequency range specified below, the assembly of Primary Coils and Shielding has a self inductance $L_p = 11.5^{\pm 10\%}$ μH for coils closest to the Interface Surface and inductance $L_p = 12.5^{\pm 10\%}$ μH for coils furthest from the Interface Surface. The value of inductance L is $3.3^{\pm 20\%}$ μH . The value of series capacitance is $C_{\text{ser}} = 168^{\pm 10\%}$ nF. The value of the parallel capacitance is $C_{\text{par}} = 400^{\pm 10\%}$ nF.

NOTE Near resonance, the voltage developed across the series capacitance can reach levels exceeding 100 V pk-pk.

Power Transmitter design A34 uses the input voltage of the inverter to control the amount of power that is transferred. For this purpose, the input voltage has a range of 2...24 V, with a resolution of 20 mV or better. The Operating Frequency is $f_{\text{op}} = 105 \dots 115$ kHz, with a duty cycle of 50%.

When a type A34 Power Transmitter first applies a Power Signal (Digital Ping; see *Parts 1 and 2: Interface Definitions*), it shall use an initial voltage of $7.0^{\pm 1.0}$ V for a bottom Primary Coil, and $6.0^{\pm 1.0}$ V for a top Primary Coil, and a recommended Operating Frequency of 110 kHz.

Control of the power transfer shall proceed using the PID algorithm, which is defined in *Parts 1 and 2: Interface Definitions*. The controlled variable $v^{(i)}$ introduced in the definition of that algorithm represents the input voltage to the inverter. In order to guarantee sufficiently accurate power control, a type A34 Power Transmitter shall determine the amplitude of the Primary Cell current—which is equal to the Primary Coil current—with a resolution of 7 mA or better. Finally, Table 94 provides the values of several parameters, which are used in the PID algorithm.

Figure 139. Electrical diagram (outline) of Power Transmitter design A34

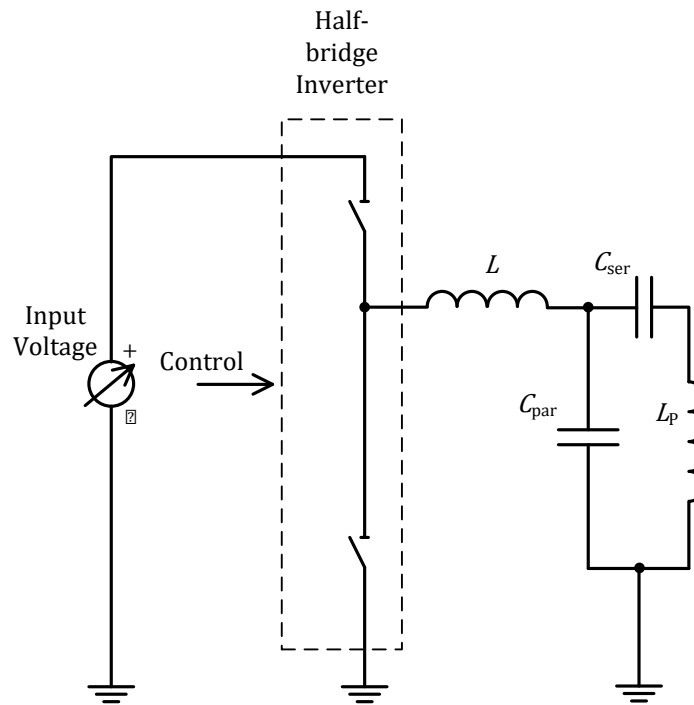

Table 94. PID parameters for voltage control

Parameter	Symbol	Value	Unit
Proportional gain	K_p	0.03	mA-1
Integral gain	K_i	0.01	mA-1ms-1
Derivative gain	K_d	0	mA-1ms
Integral term limit	M_i	3,000	N.A.
PID output limit	M_{PID}	20,000	N.A.
Scaling factor	S_v	-2	mV

2.3 Baseline Power Profile designs that activate multiple Primary Coils simultaneously

This Section 2.2.34 defines all type B Power Transmitter designs in the Baseline Power Profile. In addition to the definitions in this section, each Power Transmitter design shall implement the relevant parts of the protocols and communications interface defined in *Parts 1 and 2: Interface Definitions*.

2.3.1 Power Transmitter design B1

Power Transmitter design B1 enables Free Positioning. Figure 140 illustrates the functional block diagram of this design, which consists of two major functional units, namely a Power Conversion Unit and a Communications and Control Unit.

Figure 140. Functional block diagram of Power Transmitter design B1

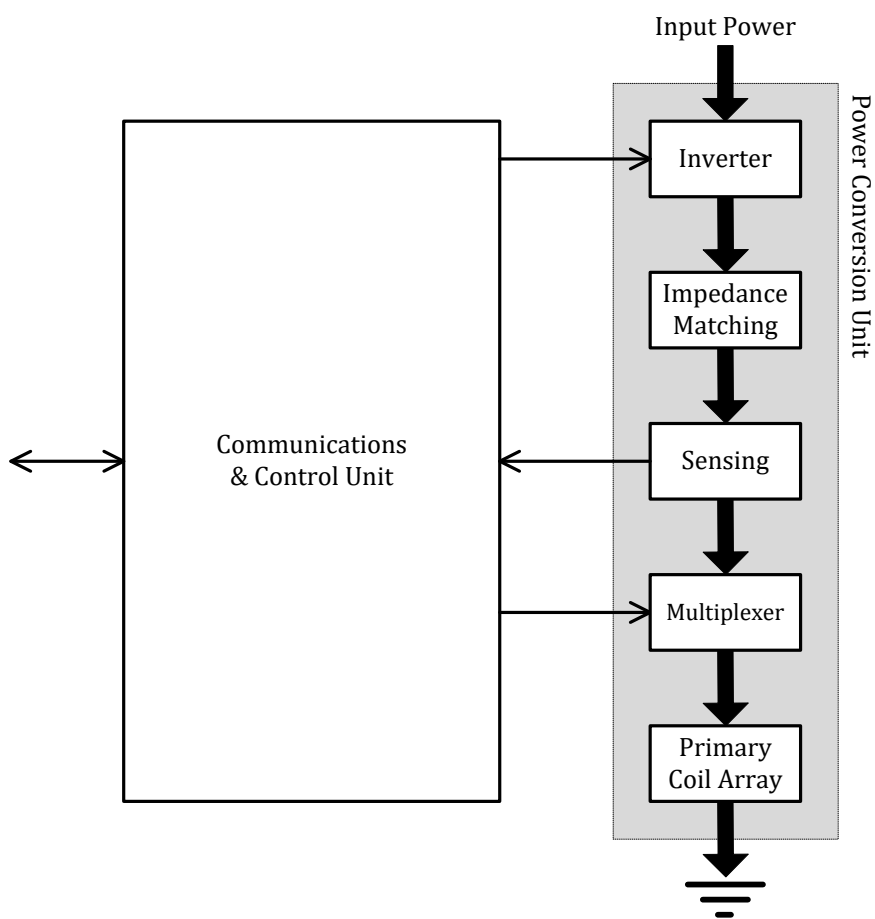

The Power Conversion Unit on the right-hand side of Figure 140 comprises the analog parts of the design. The design uses an array of partly overlapping Primary Coils to provide for Free Positioning. Depending on the position of the Power Receiver, the multiplexer connects and/or disconnects the appropriate Primary Coils. The impedance matching network forms a resonant circuit with the parts of the Primary Coil array that are connected. The sensing circuits monitor (amongst others) the Primary Cell current and voltage, and the inverter converts the DC input to an AC waveform that drives the Primary Coil array.

The Communications and Control Unit on the left-hand side of Figure 140 comprises the digital logic part of the design. This unit receives and decodes messages from the Power Receiver, configures the multiplexer to connect the appropriate parts of the Primary Coil array, executes the relevant power control algorithms and protocols, and drives the frequency and input voltage to the inverter to control the amount of power provided to the Power Receiver. The Communications and Control Unit also interfaces with the other subsystems of the Base Station, e.g. for user interface purposes.

2.3.1.1 Mechanical details

Power Transmitter design B1 includes a Primary Coil array as defined in Section 2.3.1.1.1, Shielding as defined in Section 2.3.1.1.2, and an Interface Surface as defined in Section 2.3.1.1.3.

2.3.1.1.1 Primary Coil array

The Primary Coil array consists of 3 layers. Figure 141(a) shows a top view of a single Primary Coil, which is of the wire-wound type, and consists of litz wire having 24 strands of no. 40 AWG (0.08 mm diameter), or equivalent.

Figure 141. Primary Coil array of Power Transmitter design B1

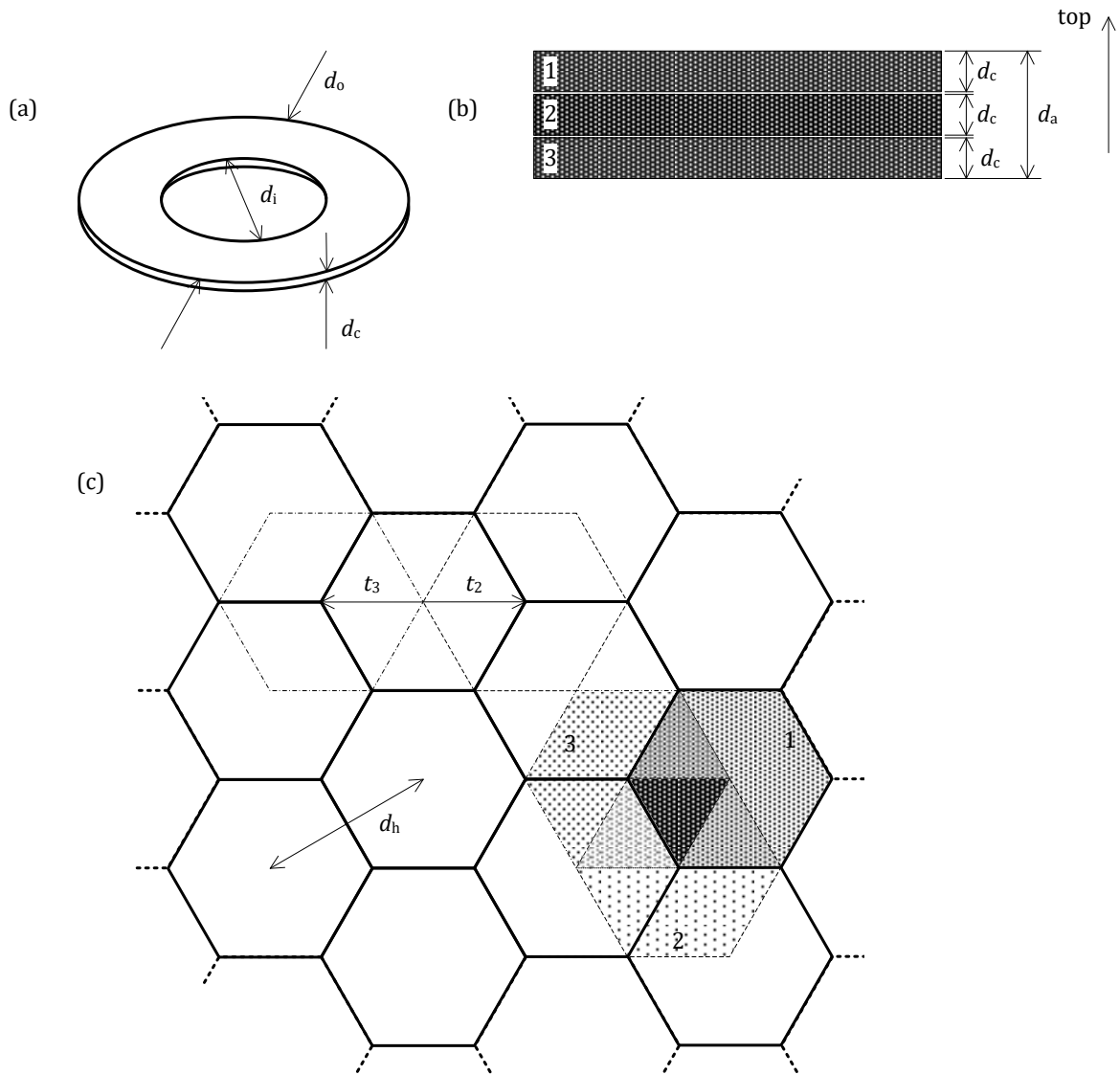

As shown in Figure 141(a), the Primary Coil has a circular shape and consists of a single layer. Figure 141(b) shows a side view of the layer structure of the Primary Coil array. Figure 141(c) provides a top view of the Primary Coil array, showing that the individual Primary Coils are packed in a hexagonal grid. The solid hexagons show the closely packed structure of the grid of Primary Coils on layer 1 of the Primary Coil array. The dashed hexagon illustrates that the grid of Primary Coils on layer 2 is offset over a distance t_2 to the right, such that the centers of the Primary Coils in layer 2 coincide with the corners of Primary Coils in layer 1. Likewise, the dash-dotted hexagon illustrates that the grid of Primary Coils on layer 3 is offset over a distance t_3 to the left, such that the centers of the Primary Coils in layer 3 coincide with the corners of Primary Coils in layer 1. As a result, the centers, respectively corners, of the Primary Coils on layer 2 and the corners, respectively centers, of the Primary Coils on layer 3 coincide as well. All Primary Coils are stacked with the same polarity. See Section 2.3.1.2 for the meaning of the shaded hexagons.

Table 95 lists the relevant parameters of the Primary Coil array.

Table 95. Primary Coil array parameters of Power Transmitter design B1

Parameter	Symbol	Value
Outer diameter	d_o	28.5 _{-0.7} mm
Inner diameter	d_i	10.5 ^{±0.3} mm
Layer thickness*	d_c	0.6 ^{+0.05} _{-0.1} mm
Number of turns	N	16
Array thickness	d_a	1.9 ^{+0.3} _{-0.2} mm
Center-to-center distance	d_h	28.6 ⁺¹ mm
Offset 2 nd layer array	t_2	16.5 ^{+0.6} mm
Offset 3 rd layer array	t_3	16.5 ^{+0.6} mm

* Value includes thickness of connection wires.

2.3.1.1.2 Shielding

As shown in Figure 142, Transmitter design B1 employs Shielding to protect the Base Station from the magnetic field that is generated in the Primary Coil array. The Shielding should be Ni-Zn or Mn-Zn ferrite and should be at least 0.5 mm thick. The Shielding extends to at least 2 mm beyond the outer edges of the Primary Coil array, and is placed at a distance of at most $d_s = 0.5$ mm below the Primary Coil array.

Figure 142. Primary Coil array assembly of Power Transmitter design B1

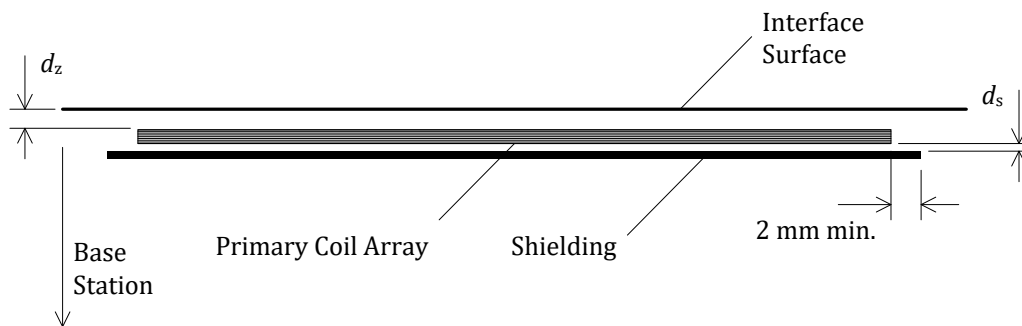

2.3.1.1.3 Interface Surface

As shown in Figure 142, the distance from the Primary Coil array to the Interface Surface of the Base Station is $d_z = 2^{+0.5}_{-0.25}$ mm, across the top face of the Primary Coil array. In addition, the Interface Surface extends at least 5 mm beyond the outer edges of the Primary Coil array.

2.3.1.2 Electrical details

As shown in Figure 143, Power Transmitter design B1 uses a half-bridge inverter to drive the Primary Coil array. In addition, Power Transmitter design B1 uses a multiplexer to select the position of the Active Area. The multiplexer shall configure the Primary Coil array in such a way that one, two, or three Primary Coils are connected—in parallel—to the driving circuit. The connected Primary Coils together constitute a Primary Cell. As an additional constraint, the multiplexer shall select the Primary Coils such that each selected Primary Coil has an overlap with every other selected Primary Coil; see Figure 140(c) for an example.

Figure 143. Electrical diagram (outline) of Power Transmitter design B1

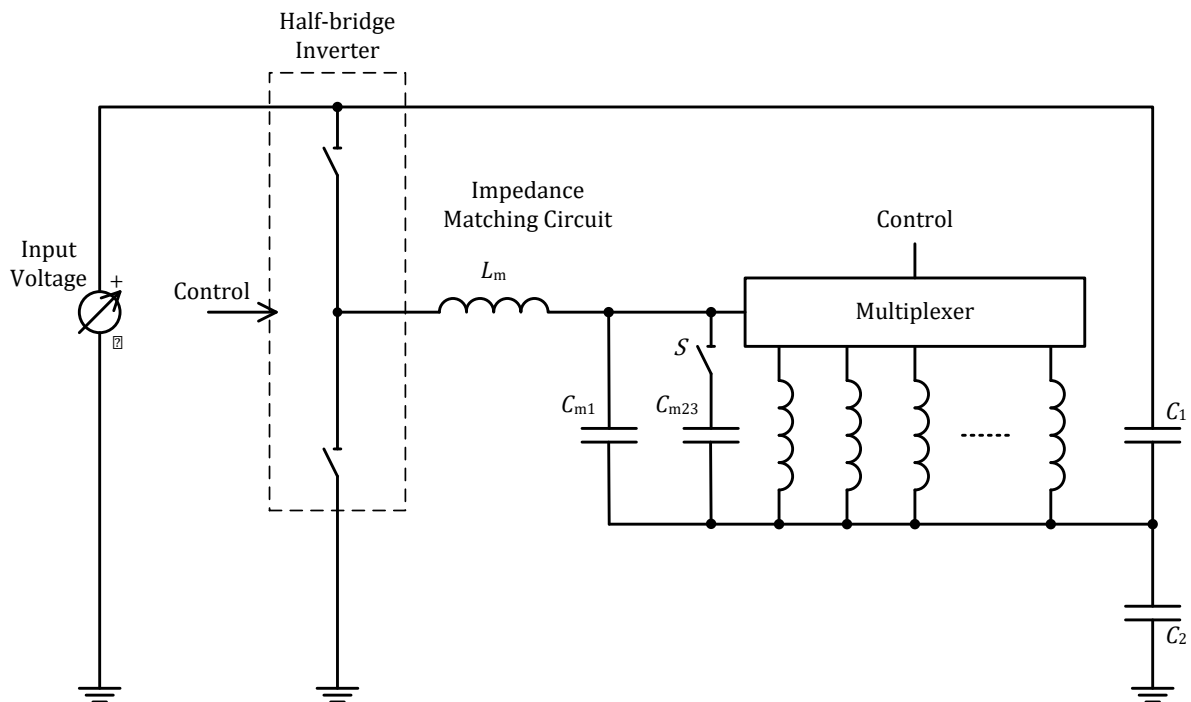

Within the Operating Frequency range $f_{op} = 105 \dots 113$ kHz, the assembly of Primary Coil array and Shielding has an inductance of $8.1^{\pm 1}$ μH for each individual Primary Coil in layer 1 (closest to the Interface Surface), $8.7^{\pm 1}$ μH for each individual Primary Coil in layer 2, and $9.6^{\pm 1}$ μH for each individual Primary Coil in layer 3. The capacitances and inductance in the impedance matching circuit are, respectively, $C_{m1} = 300^{\pm 5\%}$ nF, $C_{m23} = 200^{\pm 5\%}$ nF, and $L_m = 3.8^{\pm 5\%}$ μH . The capacitances C_1 and C_2 in the half-bridge inverter both are 68 μF . The switch S is open if the Primary Cell consists of a single Primary Coil; otherwise, the switch S is closed.

NOTE The voltage across the capacitance C_m can reach levels exceeding 36 V pk-pk.

Power Transmitter design B1 uses the input voltage to the half-bridge inverter to control the amount of power that is transferred. For this purpose, the input voltage range is 0...20 V, where a lower input voltage results in the transfer of a lower amount of power. In order to achieve a sufficiently accurate adjustment of the power that is transferred, a type B1 Power Transmitter shall be able to control the input voltage with a resolution of 35 mV or better.

When a type B1 Power Transmitter first applies a Power Signal (see the *Digital Ping* section in *Parts 1 and 2: Interface Definitions*), it shall use an initial input voltage of 12 V.

Control of the power transfer shall proceed using the PID algorithm, which is defined in the *Power transfer control* section in *Parts 1 and 2: Interface Definitions*. The controlled variable $v^{(i)}$ introduced in the definition of that algorithm represents the input voltage to the half-bridge inverter. In order to guarantee sufficiently accurate power control, a type B1 Transmitter shall determine the amplitude of the current into the Primary Cell with a resolution of 5 mA or better. In addition to the PID algorithm, a type B1 Power Transmitter shall limit the current into the Primary Cell to at most 4 A RMS in the case that the Primary Cell consists of two or three Primary Coils, or at most 2 A RMS in the case that the Primary Cell consists of one Primary Coil. For that purpose, the Power Transmitter may limit the input voltage to the half-bridge inverter to value that is lower than 20 V. Finally, Table 96 provides the values of several parameters, which are used in the PID algorithm.

Table 96. PID parameters for voltage control

Parameter	Symbol	Value	Unit
Proportional gain	K_p	1	mA ⁻¹
Integral gain	K_i	0	mA ⁻¹ ms ⁻¹
Derivative gain	K_d	0	mA ⁻¹ ms
Integral term limit	M_I	N.A.	N.A.
PID output limit	M_{PID}	2,000	N.A.
Scaling factor	S_v	-1	mV

2.3.1.3 Scalability

Sections 2.3.1.1 and 2.3.1.2 define the mechanical and electrical details of Power Transmitter design B1. As defined in Section 2.1, a type B1 Power Transmitter serves a single Power Receiver only. In order to serve multiple Power Receivers simultaneously, a Base Station may contain multiple type B1 Power Transmitters. As shown in Figure 144, these Power Transmitters may share the Primary Coil array and multiplexer. However, each individual Power Transmitter shall have a separately controllable inverter, impedance matching circuit, and means to determine the Primary Cell current, as defined in Section 2.3.1.2. In addition, the multiplexer shall ensure that it does not connect multiple inverters to any individual Primary Coil.

Figure 144. Multiple type B1 Power Transmitters sharing a multiplexer and Primary Coil array

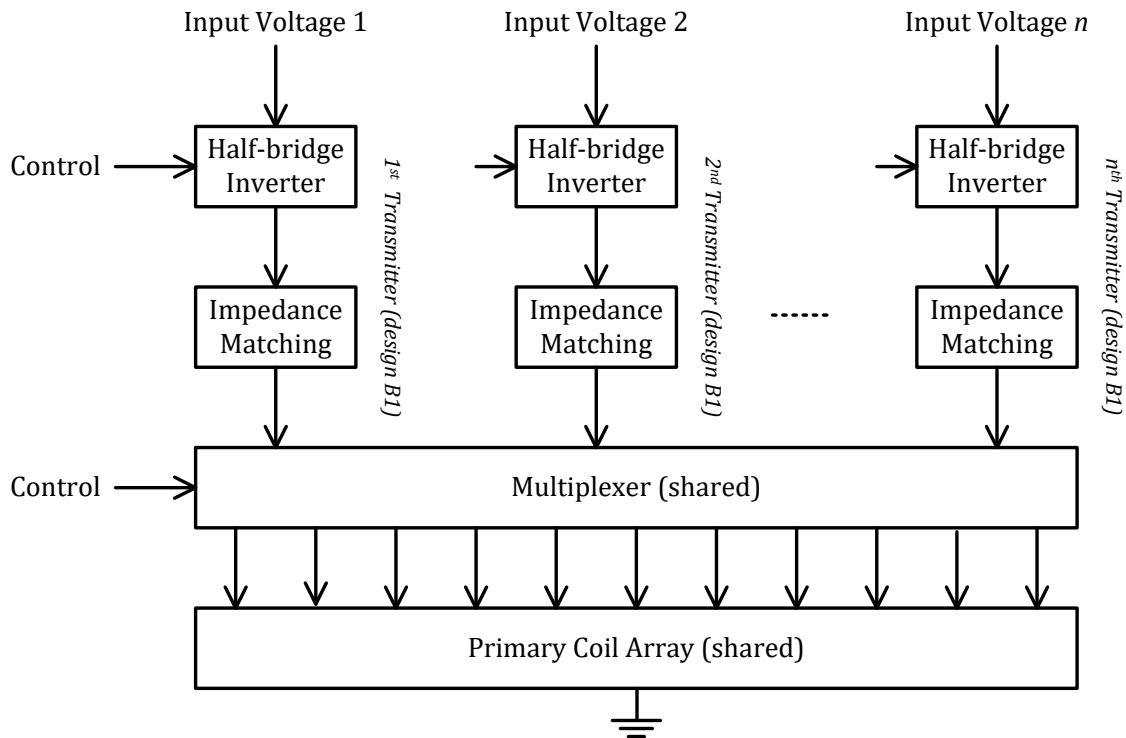

2.3.2 Power Transmitter design B2

Power Transmitter design B2 enables Free Positioning. The main difference between Power Transmitter design B2 and Power Transmitter design B1 is the Primary Coil array. Power Transmitter design B2 is based on a Printed Circuit Board (PCB) type Primary Coil array. The functional block diagram of a type B2 Power Transmitter is identical to the functional block diagram of a type B1 Power Transmitter; see Figure 140 and the descriptive text in Section 2.3.1.

2.3.2.1 Mechanical details

Power Transmitter design B2 includes a Primary Coil array as defined in Section 2.3.2.1.1, Shielding as defined in Section 2.3.2.1.2, and an Interface Surface as defined in Section 2.3.2.1.3.

2.3.2.1.1 Primary Coil array

The Primary Coil array consists of an 8 layer PCB. The inner six layers of the PCB each contain a grid of Primary Coils, and the bottom layer contains the leads to each of the individual Primary Coils. The top layer can be used for any purpose, but shall not influence the inductance values of the Primary Coils. Figure 145(a) shows a top view of a single Primary Coil, which consists of a trace that runs through 18 hexagonal turns. As shown in the top inset of Figure 145(a), the corners of this hexagonal shape are rounded. The bottom inset of Figure 145(a) shows the width of the trace as well as the distance between two adjacent turns. Figure 145(b) shows a side view of the layer structure of the PCB. Copper layers 2, 3, 4, 5, 6, and 7 each contain a grid of Primary Coils. Copper layer 8 contains the leads to each of the Primary Coils. Figure 145(c) provides a top view of the Primary Coil array, showing that the individual Primary Coils are packed in a hexagonal grid. The solid hexagons show the closely packed structure of the grids of Primary Coils on layer 2 and layer 7 of the Primary Coil array. Each solid hexagon represents a set of two identical Primary Coils—in this case one Primary Coil on layer 2 and one Primary Coil on layer 7, respectively—which are connected in parallel. The dashed hexagon illustrates that the grids of Primary Coils on layer 3 and layer 6 are offset over a distance t_2 to the right, such that the centers of the Primary Coils in layer 3 and layer 6 coincide with the corners of Primary Coils in layer 2 and layer 7. Likewise, the dash-dotted hexagon illustrates that the grids of Primary Coils on layer 4 and layer 5 are offset over a distance t_3 to the left, such that the centers of the Primary Coils in layer 4 and layer 5 coincide with the corners of Primary Coils in layer 2 and layer 7. As a result, the centers, respectively corners, of the Primary Coils on layer 3 and layer 6 and the corners, respectively centers, of the Primary Coils on layer 4 and layer 5 coincide as well. See Section 2.3.2.2 for the meaning of the shaded hexagons.

Table 97. Primary Coil array parameters of Power Transmitter design B2

Parameter	Symbol	Value
Outer diameter	d_o	$31^{\pm 0.4}$ mm
Track width	d_w	$0.42^{\pm 0.03}$ mm
Track width plus spacing	$d_w + d_s$	$0.6^{\pm 0.03}$ mm
Corner rounding*	r_c	$5^{\pm 3}$ mm
Number of turns	N	18
Track thickness	d_{Cu}	$0.07^{\pm 0.014}$ mm
Dielectric thickness 1	d_{d1}	$0.089_{-0}^{+0.15}$ mm
Dielectric thickness 2	d_{d2}	$0.1^{\pm 0.013}$ mm
Array thickness	d_a	$1.14^{\pm 0.05}$ mm
Center-to-center distance	d_h	$31.855^{\pm 0.2}$ mm
Offset 2 nd layer array	t_2	$18.4^{\pm 0.1}$ mm
Offset 3 rd layer array	t_3	$18.4^{\pm 0.1}$ mm

* Value applies to the outermost winding.

Table 97 lists the relevant parameters of the Primary Coil array. The finished PCB thickness is $1.3^{\pm 10\%}$ mm.

Figure 145. Primary Coil array of Power Transmitter design B2

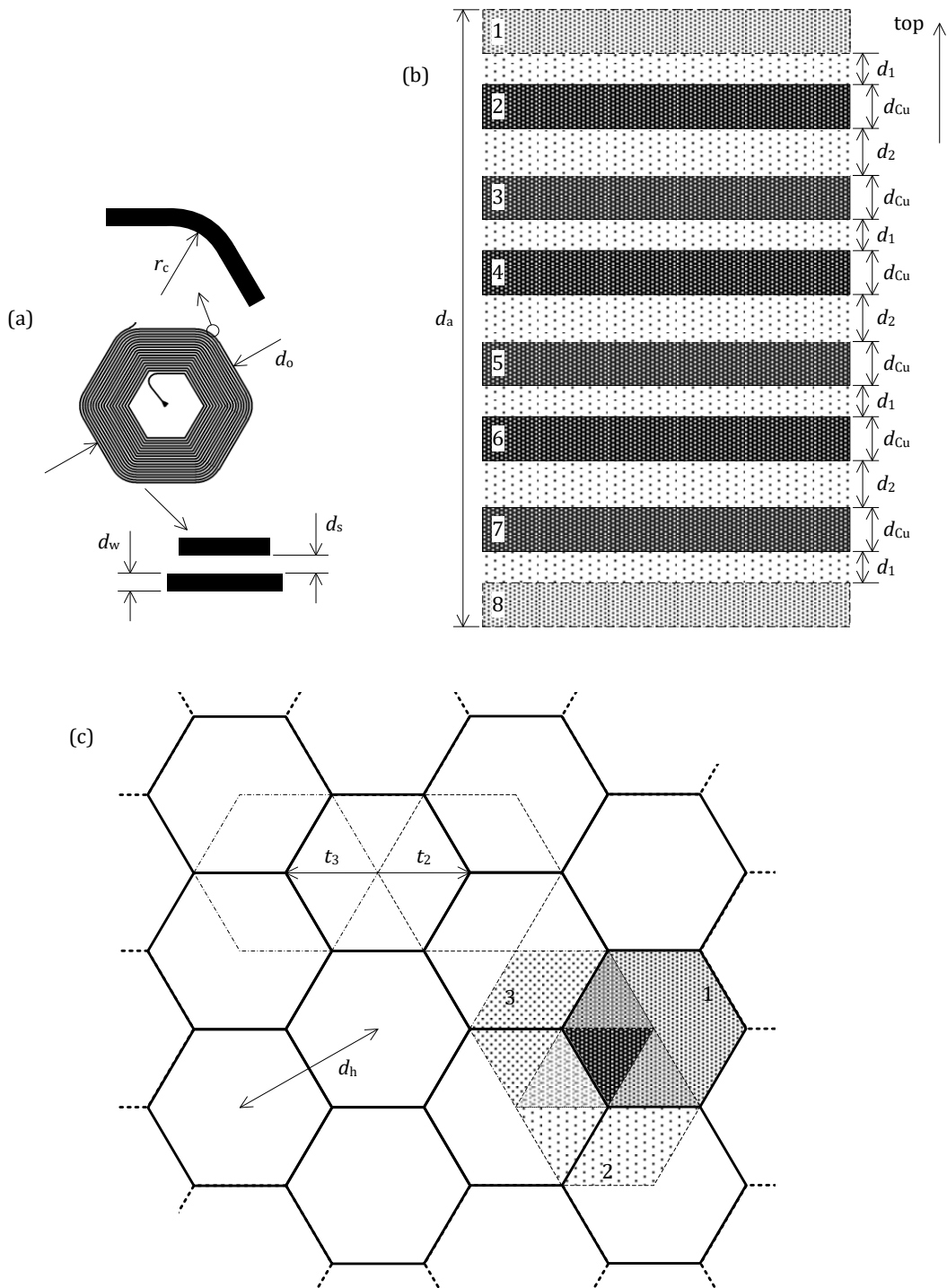

2.3.2.1.2 Shielding

Power Transmitter design B2 employs Shielding that is identical to the Shielding of Power Transmitter design B1. See Section 2.3.1.1.2.

2.3.2.1.3 Interface Surface

The distance from the Primary Coil array to the Interface Surface of the Base Station is $d_z = 2^{+0.1}_{-0.5}$ mm, across the top face of the Primary Coil array. See also Figure 142 in Section 2.3.1.1.3. In addition, the Interface Surface extends at least 5 mm beyond the outer edges of the Primary Coil array.

2.3.2.2 Electrical details

The outline of the electrical diagram of Power Transmitter design B2 follows the outline of the electrical diagram of Power Transmitter design B1. See also Figure 143 in Section 2.3.1.2.

Power Transmitter design B2 uses a half-bridge inverter to drive the Primary Coil array. In addition, Power Transmitter design B2 uses a multiplexer to select the position of the Active Area. The multiplexer shall configure the Primary Coil array in such a way that one, two, or three sets of two Primary Coils are connected—in parallel—to the driving circuit. The connected Primary Coils together constitute a Primary Cell. As an additional constraint, the multiplexer shall select the Primary Coils such that each selected Primary Coil has an overlap with every other selected Primary Coil; see Figure 145(c) for an example.

Within the Operating Frequency range $f_{op} = 105 \dots 113$ kHz, the assembly of Primary Coil array and Shielding has an inductance of $11.7^{\pm 1}$ μ H for each set of Primary Coils in layer 2 and layer 7 (connected in parallel), $11.8^{\pm 1}$ μ H for each set of Primary Coils in layer 3 and layer 6 (connected in parallel), and $12.3^{\pm 1}$ μ H for each set of Primary Coils in layer 4 and 5 (connected in parallel). The capacitance and inductance in the impedance matching circuit (Figure 143) are, respectively, $C_{m1} = 256^{\pm 5\%}$ nF, $C_{m23} = 147^{\pm 5\%}$ nF and $L_m = 3.8^{\pm 5\%}$ μ H. The capacitances C_1 and C_2 in the half-bridge inverter both are 68 μ F. The switch S is open if the Primary Cell consists of a single Primary Coil; otherwise, the switch S is closed.

NOTE The voltage across the capacitance C_m can reach levels exceeding 36 V pk-pk.

Power Transmitter design B2 uses the input voltage to the half-bridge inverter to control the amount of power that is transferred. For this purpose, the input voltage range is 0...20 V, where a lower input voltage results in the transfer of a lower amount of power. In order to achieve a sufficiently accurate adjustment of the power that is transferred, a type B2 Power Transmitter shall be able to control the input voltage with a resolution of 35 mV or better.

When a type B2 Power Transmitter first applies a Power Signal (see the *Digital Ping* section in *Parts 1 and 2: Interface Definitions*), it shall use an initial input voltage of 12 V.

Control of the power transfer shall proceed using the PID algorithm, which is defined in the *Power transfer control* section in *Parts 1 and 2: Interface Definitions*. The controlled variable $v^{(i)}$ introduced in the definition of that algorithm represents the input voltage to the half-bridge inverter. In order to guarantee sufficiently accurate power control, a type B2 Transmitter shall determine the amplitude of the current into the Primary Cell (i.e. the sum of the currents through each of its three constituent Primary Coils) with a resolution of 5 mA or better. In addition to the PID algorithm, a type B2 Power Transmitter shall limit the current into the Primary Cell to at most 3.5 A RMS in the case that the Primary Cell consists of two or three Primary Coils, or at most 1.75 A RMS in the case that the Primary Cell consists of one Primary Coil. For that purpose, the Power Transmitter may limit the input voltage to the half-bridge inverter to value that is lower than 20 V. Finally, Table 96 in Section 2.3.1.2 provides the values of several parameters, which are used in the PID algorithm.

2.3.2.3 Scalability

Power Transmitter Design B2 offers the same scalability options as Power Transmitter design B1. See Section 2.3.1.3.

2.3.3 Power Transmitter design B3

Power Transmitter design B3 enables Free Positioning, and has a design similar to Power Transmitter design B1. See Section 2.3.1 for an overview.

2.3.3.1 Mechanical details

Power Transmitter design B3 includes a Primary Coil array as defined in Section 2.3.3.1.1, Shielding as defined in Section 2.3.3.1.2, and an Interface Surface as defined in Section 2.3.3.1.3.

2.3.3.1.1 Primary Coil array

The Primary Coil array consists of a hybrid PCB/wire wound coil structure. As shown Figure 146(a), the central part of this structure is a 4-layer PCB. The inner two layers of this PCB each contain an identical grid of coils, where corresponding coils are connected in parallel to form a single two-layer Primary Coil. The outer two layers of the PCB serve as a mounting area for the wire wound Primary Coils (layers (a) and (b)). In addition, layer 4 of the PCB contains the leads to both the internal and the wire wound Primary Coils; and layer 1 can be used for any purpose, but shall not influence the inductance values of the Primary Coils.

The wire-wound Primary Coils consist of litz wire having 24 strands of no. 40 AWG (0.08 mm diameter), or equivalent. Each wire wound Primary Coil has a circular shape as shown in Figure 146(b).

Each Primary Coil inside the PCB consists of a trace that runs through 18 hexagonal turns as shown in Figure 146(c), and are identical to the Primary Coils of Power Transmitter design B2 defined in Section 2.3.2.1.1.

Figure 146(d) provides a top view of the Primary Coil array, showing that the individual Primary Coils are packed in a hexagonal grid. The solid hexagons show the closely packed structure of the grid of Primary Coils on layer (a) of the Primary Coil array. The dashed hexagon illustrates that the identical grids of Primary Coils on layers (2) and (3) are offset over a distance t_2 to the right, such that the centers of the Primary Coils in layers (2) and (3) coincide with the corners of Primary Coils in layer (a). Likewise, the dash-dotted hexagon illustrates that the grid of Primary Coils on layer (b) is offset over a distance t_3 to the left, such that the centers of the Primary Coils in layer (b) coincide with the corners of Primary Coils in layer (a). As a result, the centers, respectively corners, of the Primary Coils on layer (2) and (3), and the corners, respectively centers, of the Primary Coils on layer (b) coincide as well. All Primary Coils are stacked with the same polarity. See Section 2.3.3.2 for the meaning of the shaded hexagons.

Table 98 lists the relevant parameters of the Primary Coil array.

Figure 146. Primary Coil array of Power Transmitter design B3

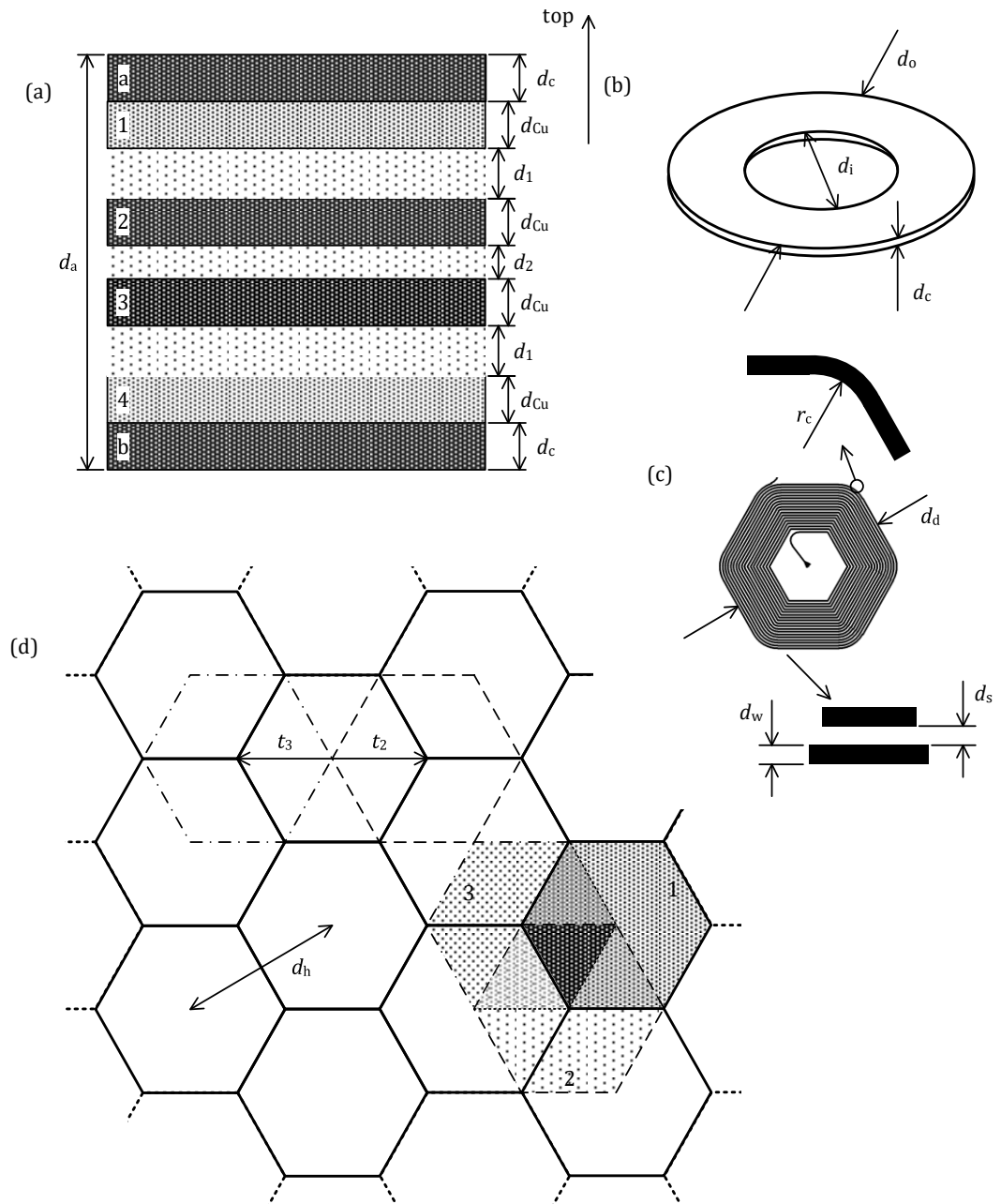

Table 98. Primary Coil array parameters of Power Transmitter design B3

Parameter	Symbol	Value
Outer diameter	d_o	$31.1^{\pm 0.5}$ mm
Inner diameter	d_i	$10.6^{\pm 0.3}$ mm
Layer thickness	d_c	$0.4^{\pm 0.05}$ mm
Number of turns	N	18
Outer diameter	d_d	$31^{\pm 0.4}$ mm
Track width	d_w	$0.42^{\pm 0.03}$ mm
Track width plus spacing	$d_w + d_s$	$0.6^{\pm 0.03}$ mm
Corner rounding*	r_c	$5^{\pm 3}$ mm
Number of turns	N	18
Track thickness	d_{Cu}	$0.07^{\pm 0.015}$ mm
Dielectric thickness 1	d_{d1}	$0.088_{-0}^{+0.1}$ mm
Dielectric thickness 2	d_{d2}	$0.145^{\pm 0.02}$ mm
PCB thickness		$0.6^{\pm 0.1}$ mm
Array thickness	d_a	$1.5^{\pm 0.2}$ mm
Center-to-center distance	d_h	$31.855^{\pm 0.2}$ mm
Offset 2 nd layer array	t_2	$18.4^{\pm 0.1}$ mm
Offset 3 rd layer array	t_3	$18.4^{\pm 0.1}$ mm

2.3.3.1.2 Shielding

As shown in Figure 147, Transmitter design B3 employs Shielding to protect the Base Station from the magnetic field that is generated in the Primary Coil array. The Shielding should be Ni-Zn or Mn-Zn ferrite and should be at least 0.5 mm thick. The Shielding extends to at least 2 mm beyond the outer edges of the Primary Coil array, and is placed at a distance of at most $d_s = 0.5$ mm below the Primary Coil array.

Figure 147. Primary Coil array assembly of Power Transmitter design B3

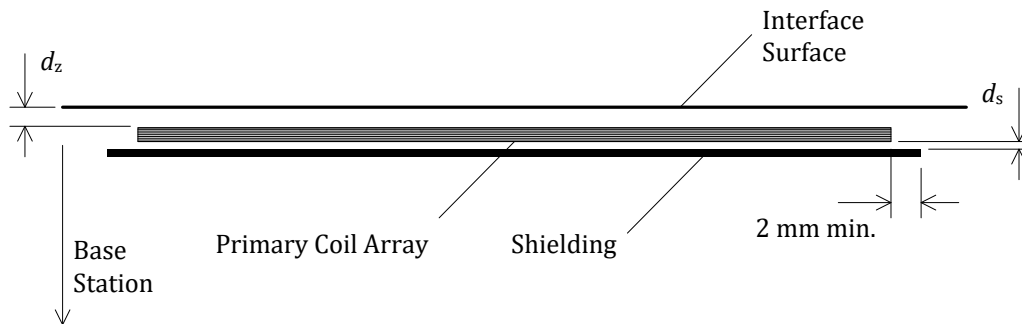

2.3.3.1.3 Interface Surface

As shown in Figure 147, the distance from the Primary Coil array to the Interface Surface of the Base Station is $d_z = 2^{+0.1}_{-0.5}$ mm, across the top face of the Primary Coil array. In addition, the Interface Surface extends at least 5 mm beyond the outer edges of the Primary Coil array.

2.3.3.2 Electrical details

As shown in Figure 148, Power Transmitter design B3 uses a full-bridge inverter to drive the Primary Coil array. In addition, Power Transmitter design B3 uses a multiplexer to select the position of the Active Area. The multiplexer shall configure the Primary Coil array in such a way that one, two, or three Primary Coils are connected—in parallel—to the driving circuit. The connected Primary Coils together constitute a Primary Cell. As an additional constraint, the multiplexer shall select the Primary Coils such that each selected Primary Coil has an overlap with every other selected Primary Coil; see Figure 146(d) for an example.

Figure 148. Electrical diagram (outline) of Power Transmitter design B3

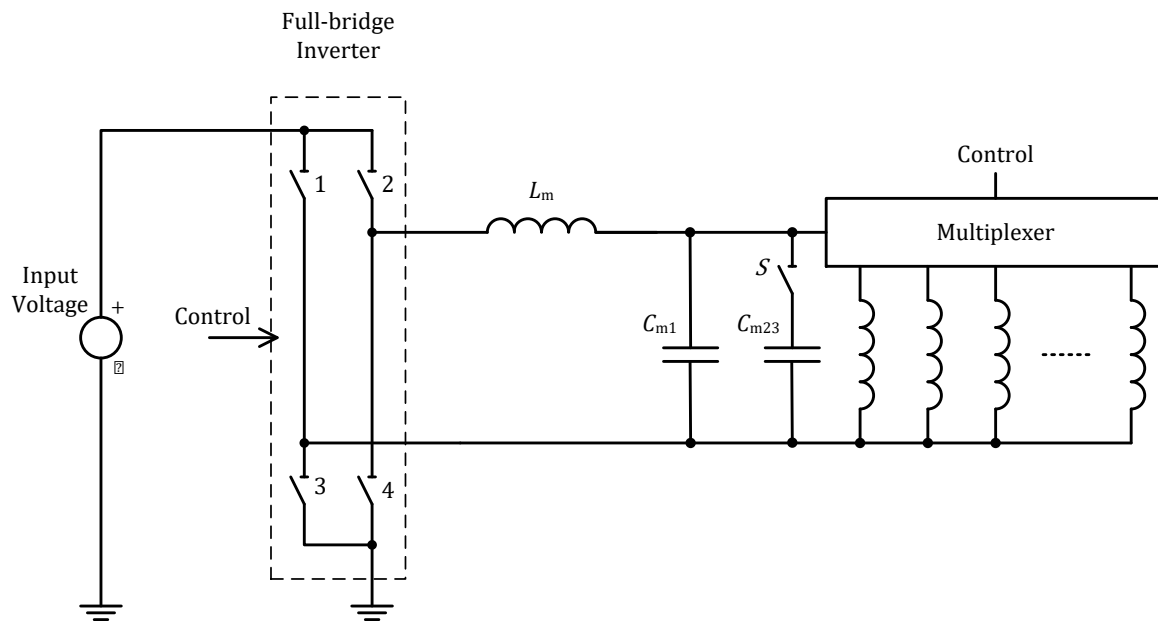

Within the Operating Frequency range $f_{op} = 105 \dots 113$ kHz, the assembly of Primary Coil array and Shielding has an inductance of $11.6^{\pm 1}$ μH for each individual Primary Coil in layer (a) (closest to the Interface Surface), $12.4^{\pm 1}$ μH for each individual Primary Coil in PCB layers 2 and 3, and $13.5^{\pm 1.5}$ μH for each individual Primary Coil in layer (b). The capacitances and inductance in the impedance matching circuit are, respectively, $C_{m1} = 222^{\pm 5\%}$ nF, $C_{m23} = 133^{\pm 5\%}$ nF, and $L_m = 3.8^{\pm 5\%}$ μH . The switch S is open if the Primary Cell consists of a single Primary Coil; otherwise, the switch S is closed. The input voltage to the full-bridge inverter is $12^{\pm 5\%}$ V.

NOTE The voltage across the capacitance C_m can reach levels exceeding 36 V pk-pk.

Power Transmitter design B3 uses the phase difference between the control signals to two halves of the full-bridge inverter to control the amount of power that is transferred, see Figure 149. For this purpose, the range of the phase difference α is $0\dots180^\circ$ —with a larger phase difference resulting in a lower power transfer. In order to achieve a sufficient accurate adjustment of the power that is transferred, a type B3 Power transmitter shall be able to control the phase difference with a resolution of 0.42° or better. When a type B3 Power Transmitter first applies a Power Signal (see the *Digital Ping* section in *Parts 1 and 2: Interface Definitions*), it shall use an initial phase difference of 120° .

Figure 149. Control signals to the inverter

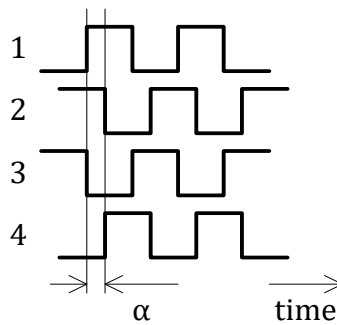

Control of the power transfer shall proceed using the PID algorithm, which is defined in the *Power transfer control* section in *Parts 1 and 2: Interface Definitions*. The controlled variable $v^{(i)}$ introduced in the definition of that algorithm represents the phase difference between the two halves of the full-bridge inverter. In order to guarantee sufficiently accurate power control, a type B3 Transmitter shall determine the amplitude of the current into the Primary Cell with a resolution of 5 mA or better. In addition to the PID algorithm, a type B3 Power Transmitter shall limit the current into the Primary Cell to at most 4 A RMS in the case that the Primary Cell consists of two or three Primary Coils, or at most 2 A RMS in the case that the Primary Cell consists of one Primary Coil. Finally, Table 99 provides the values of several parameters that are used in the PID algorithm.

Table 99. PID parameters for voltage control

Parameter	Symbol	Value	Unit
Proportional gain	K_p	1	mA^{-1}
Integral gain	K_i	0	$\text{mA}^{-1}\text{ms}^{-1}$
Derivative gain	K_d	0	mA^{-1}ms
Integral term limit	M_i	N.A.	N.A.
PID output limit	M_{PID}	2,000	N.A.
Scaling factor	S_v	0.01	$^\circ$

2.3.3.3 Scalability

Power Transmitter Design B3 offers the same scalability options as Power Transmitter design B1. See Section 2.3.1.3.

2.3.4 Power Transmitter design B4

Power Transmitter design B4 enables Free Positioning. Figure 150 illustrates the functional block diagram of this design, which consists of two major functional units, namely a Power Conversion Unit and a Communications and Control Unit.

Figure 150. Functional block diagram of Power Transmitter design B4

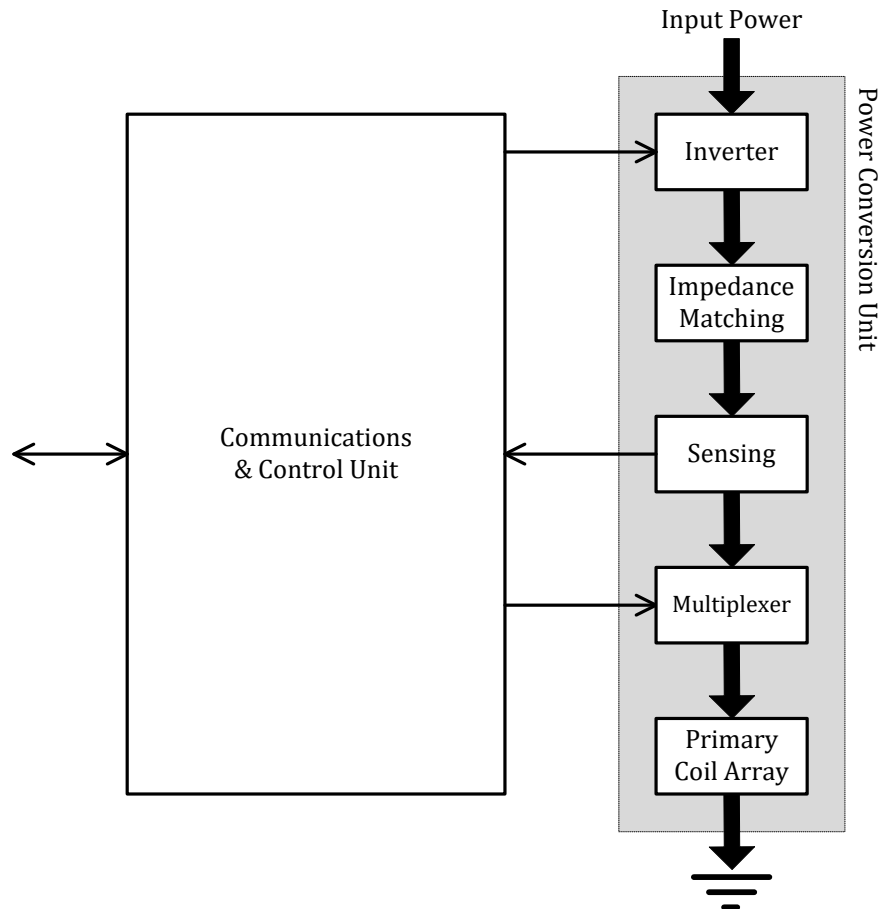

The Power Conversion Unit on the right-hand side of Figure 150 comprises the analog parts of the design. The design uses an array of partly overlapping Primary Coils to provide for Free Positioning. Depending on the position of the Power Receiver, the multiplexer connects and/or disconnects the appropriate Primary Coils. The impedance matching network forms a resonant circuit with the parts of the Primary Coil array that are connected. The sensing circuits monitor (amongst others) the Primary Cell current and voltage, and the inverter converts the DC input to an AC waveform that drives the Primary Coil array.

The Communications and Control Unit on the left-hand side of Figure 150 comprises the digital logic part of the design. This unit receives and decodes messages from the Power Receiver, configures the multiplexer to connect the appropriate parts of the Primary Coil array, executes the relevant power control algorithms and protocols, and drives the inverter to control the amount of power provided to the Power Receiver. The Communications and Control Unit also interfaces with the other subsystems of the Base Station, e.g. for user interface purposes.

2.3.4.1 Mechanical details

Power Transmitter design B4 includes a Primary Coil array as defined in Section 2.3.4.1.1, Shielding as defined in Section 2.3.4.1.2, and an Interface Surface as defined in Section 2.3.4.1.3.

2.3.4.1.1 Primary Coil array

The Primary Coil array consists of partly overlapping square shaped planar coils. Figure 151(a) shows a top view of a single Primary Coil, which consists of a bifilar trace that runs through 11 square shaped turns in a single layer of a PCB. Another realization of a single Primary Coil is to construct it from litz wire having 24 strands of no. 40 AWG (0.08 mm diameter), or equivalent. Figure 151(b) shows a top view of such wire-wound Primary Coil. Table 100 lists the relevant parameters of the coils shown in Figure 151.

Figure 151. Top view of PCB and wire-wound Primary Coil of Power Transmitter design B4

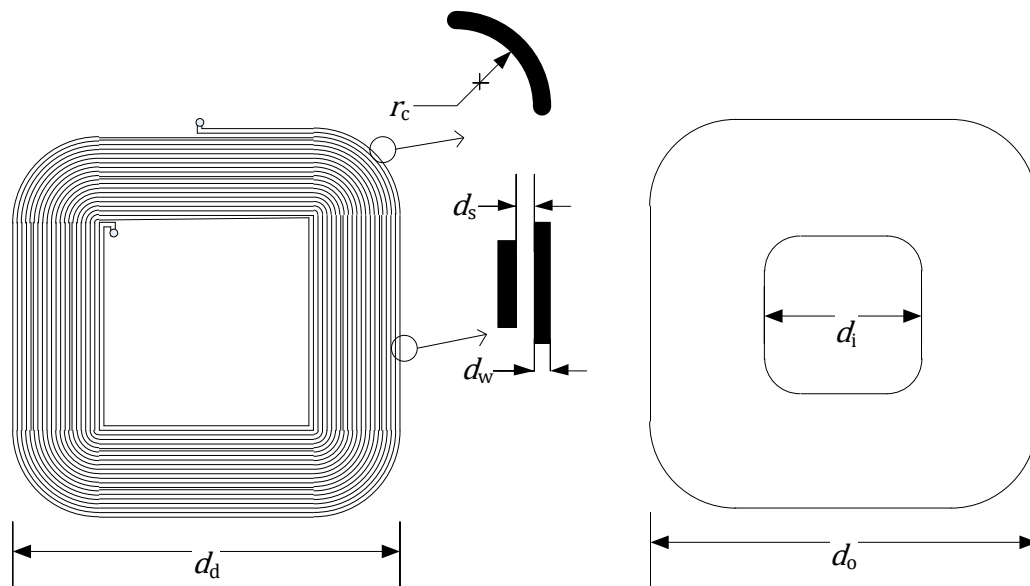

Table 100. Primary Coil parameters of Power Transmitter design B4

Parameter	Symbol	Value
<i>Litz wire based Primary Coil</i>		
Outer diameter	d_o	$45.0^{+0.5}_{-1.0}$ mm
Inner diameter	d_i	$18.6^{\pm 0.3}$ mm
Number of turns	N	11
<i>PCB based Primary Coil</i>		
Outer diameter	d_d	$45^{\pm 0.4}$ mm
Track width	d_w	$0.42^{\pm 0.03}$ mm
Track width plus spacing	$d_w + d_s$	$0.6^{\pm 0.03}$ mm
Corner rounding*	r_c	$9^{\pm 1}$ mm
Number of turns	N	11

* Value applies to the outermost winding.

The Primary Coil array may be constructed from PCB-coils, wire-wound coils or any combination thereof (hybrid). Power Transmitter design B4 enables one-dimensional freedom of positioning. For that purpose the Primary Coils are placed in a row, such that there is an overlap of approximately two-thirds of the area. Each Primary Coil (except for the Primary Coils at both ends of the Primary Coil array) overlaps with two Primary Coils in different layers. Figure 152 shows the layout of the Primary Coil array. Figure 153 shows the layered structure of the Primary Coil array in the case of a PCB only implementation, a litz wire only implementation and a hybrid PCB-litz wire implementation. Table 101 lists the relevant parameters of the Primary Coil array. Any layer of the PCB—if present—may contain functionality other than, or in addition to, the Primary Coils. If such other functionality is present, that functionality shall not affect the inductance values of the Primary Coils.

Figure 152. Top view (a) and cross section (b) of the Primary Coil array of Power Transmitter design B4.

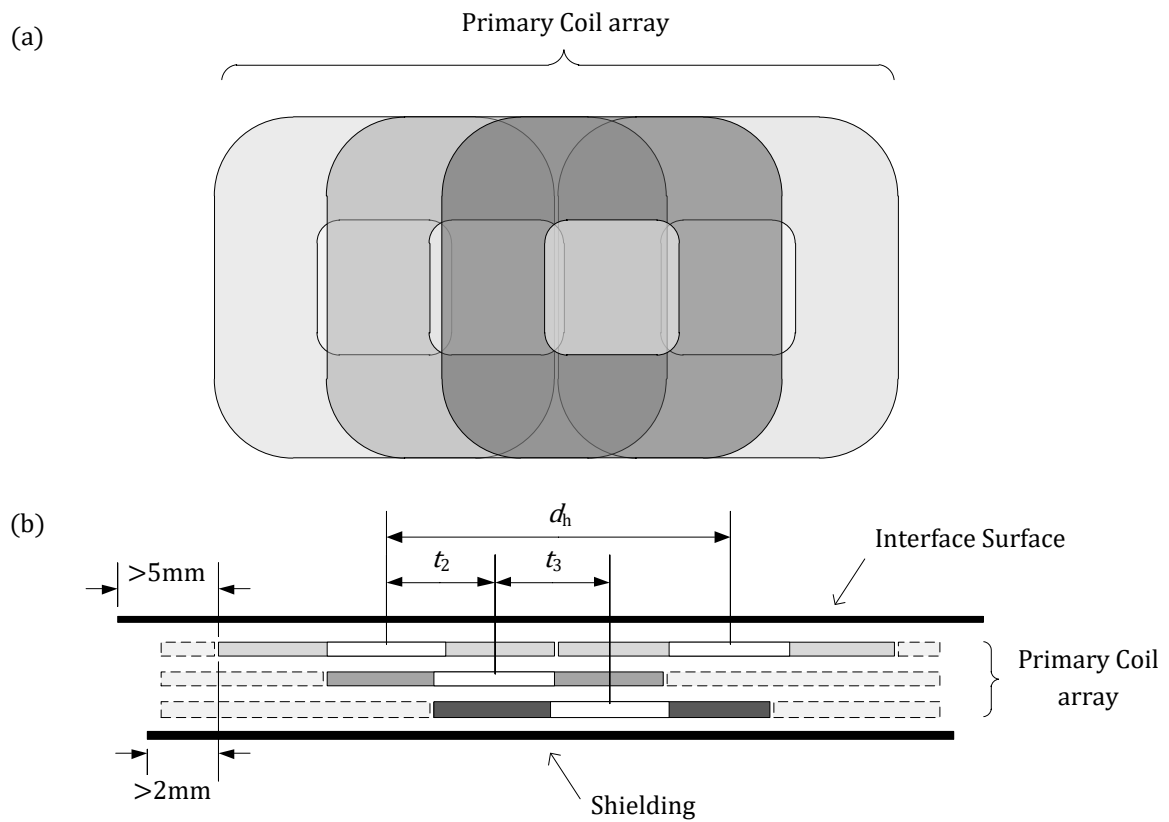

Figure 153. Layered structure of the Primary Coil array

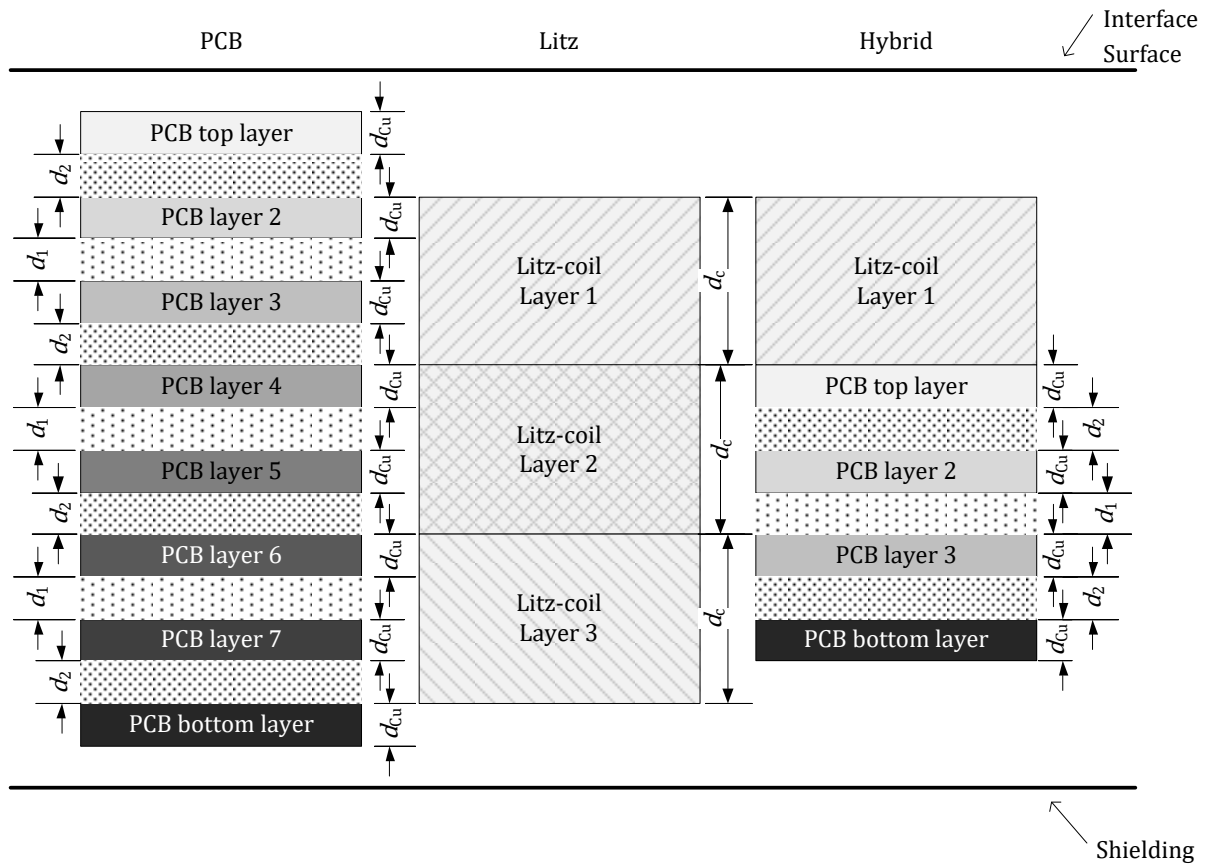

Table 101. Primary Coil array parameters of Power Transmitter design B4

Parameter	Symbol	Value
Center-to-center distance	d_h	$46.5^{±0.2}$ mm
Offset 2 nd layer array	t_2	$15.5^{±0.1}$ mm
Offset 3 rd layer array	t_3	$15.5^{±0.1}$ mm
Litz-layer thickness	d_c	$0.4^{+0.1}_{-0.05}$ mm
PCB-copper thickness	d_{Cu}	$0.07^{±0.015}$ mm
Dielectric thickness 1	d_{d1}	$0.088^{+0.15}_0$ mm
Dielectric thickness 2	d_{d2}	$0.126^{±0.039}$ mm

2.3.4.1.2 Shielding

As shown in Figure 153, Transmitter design B4 employs Shielding to protect the Base Station from the magnetic field that is generated in the Primary Coil array. The Shielding should be Ni-Zn or Mn-Zn ferrite and should be at least 0.5 mm thick. The Shielding extends to at least 2 mm beyond the outer edges of the Primary Coil array, and is placed at a distance of at most $d_s = 0.5$ mm below the Primary Coil array.

Figure 154. Primary Coil array assembly of Power Transmitter design B4

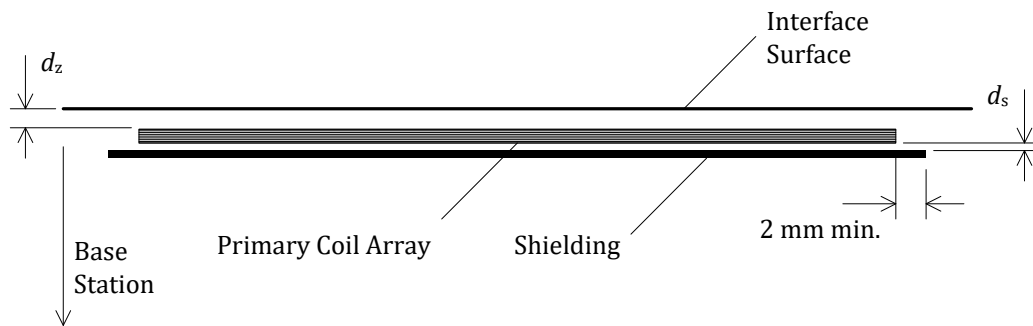

2.3.4.1.3 Interface Surface

As shown in Figure 154, the distance from the Primary Coil array to the Interface Surface of the Base Station is $d_z = 2^{\pm 0.5}$ mm, across the top face of the Primary Coil array. In addition, the Interface Surface extends at least 5 mm beyond the outer edges of the Primary Coil array.

2.3.4.2 Electrical details

As shown in Figure 155, Power Transmitter design B4 uses a full-bridge inverter to drive the Primary Coil array. In addition, Power Transmitter design B4 uses a multiplexer to select the position of the Active Area. The multiplexer shall configure the Primary Coil array in such a way that one, or two Primary Coils are connected—in parallel—to the driving circuit. The connected Primary Coils together constitute a Primary Cell. In the case that two Primary Coils are selected, these two Primary Coils shall have an overlap of two-thirds of the area of a single Primary Coil.

Figure 155. Electrical diagram (outline) of Power Transmitter design B4

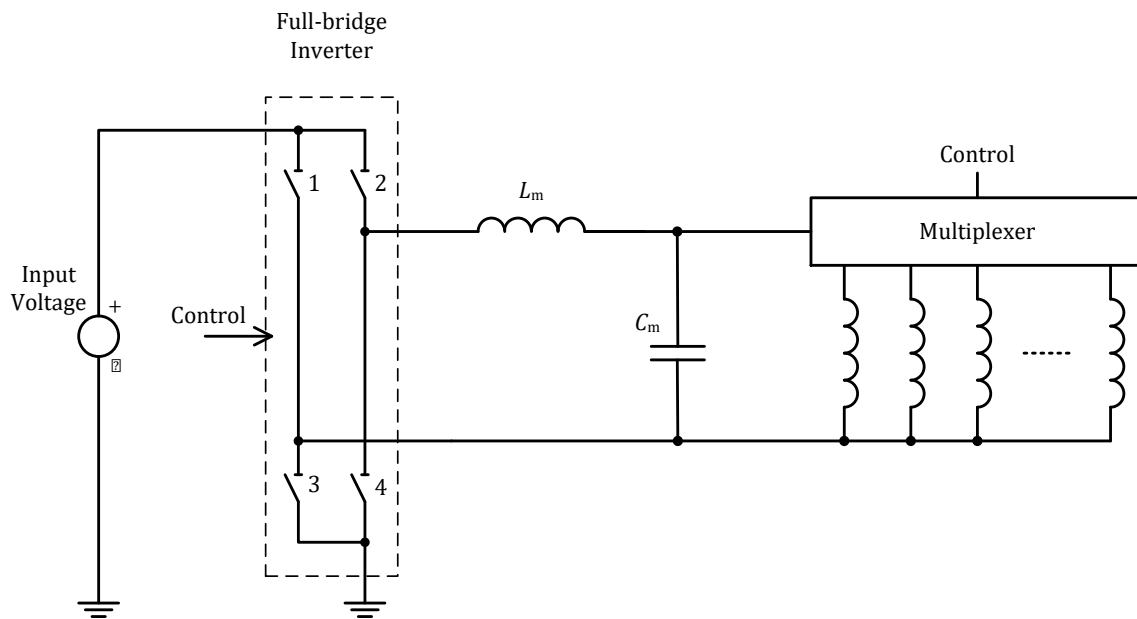

Within the Operating Frequency range $f_{op} = 105 \dots 113$ kHz, the assembly of Primary Coil array and Shielding has an inductance of $8.8^{\pm 1} \mu\text{H}$ for each individual Primary Coil in layer (a) (closest to the Interface Surface), $9.1^{\pm 1} \mu\text{H}$ for each individual Primary Coil in layer (b), and $9.5^{\pm 1} \mu\text{H}$ for each individual Primary Coil in layer (c) (closest to the Shielding). The capacitances and inductance in the impedance matching circuit are, respectively, $C_m = 300^{\pm 5\%} \text{ nF}$, and $L_m = 3.8^{\pm 5\%} \mu\text{H}$. The input voltage to the full-bridge inverter is $12^{\pm 5\%} \text{ V}$.

NOTE The voltage across the capacitance C_m can reach levels exceeding 36 V pk-pk.

Power Transmitter design B4 uses the phase difference between the control signals to two halves of the full-bridge inverter to control the amount of power that is transferred, see Figure 156. For this purpose, the range of the phase difference α is $0\dots180^\circ$ —with a larger phase difference resulting in a lower power transfer. In order to achieve a sufficient accurate adjustment of the power that is transferred, a type B4 Power Transmitter shall be able to control the phase difference with a resolution of 0.42° or better. When a type B4 Power Transmitter first applies a Power Signal (see the *Digital Ping* section in *Parts 1 and 2: Interface Definitions*), it shall use an initial phase difference of 120° .

Figure 156. Control signals to the inverter

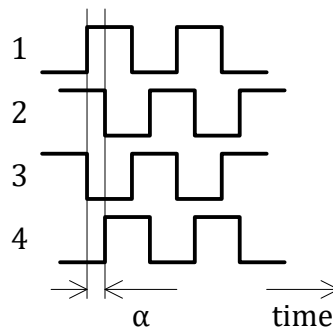

Control of the power transfer shall proceed using the PID algorithm, which is defined in the *Power transfer control* section in *Parts 1 and 2: Interface Definitions*. The controlled variable $v^{(l)}$ introduced in the definition of that algorithm represents the phase difference between the two halves of the full-bridge inverter. In order to guarantee sufficiently accurate power control, a type B4 Transmitter shall determine the amplitude of the current into the Primary Cell with a resolution of 5 mA or better. In addition to the PID algorithm, a type B4 Power Transmitter shall limit the current into the Primary Cell to at most 4 A RMS in the case that the Primary Cell consists of two Primary Coils, or at most 2 A RMS in the case that the Primary Cell consists of one Primary Coil. Finally, Table 102 provides the values of several parameters, which are used in the PID algorithm.

Table 102. Control parameters for power control

Parameter	Symbol	Value	Unit
Proportional gain	K_p	1	mA^{-1}
Integral gain	K_i	0	$\text{mA}^{-1}\text{ms}^{-1}$
Derivative gain	K_d	0	mA^{-1}ms
Integral term limit	M_I	N.A.	N.A.
PID output limit	M_{PID}	2,000	N.A.
Scaling factor	S_v	0.01	$^\circ$

2.3.4.3 Scalability

Power Transmitter Design B4 offers the same scalability options as Power Transmitter design B1. See Section 2.3.1.3.

2.3.5 Power Transmitter design B5

Figure 157 illustrates the functional block diagram of Power Transmitter design B5, which consists of two major functional units, namely a Power Conversion Unit and a Communications and Control Unit.

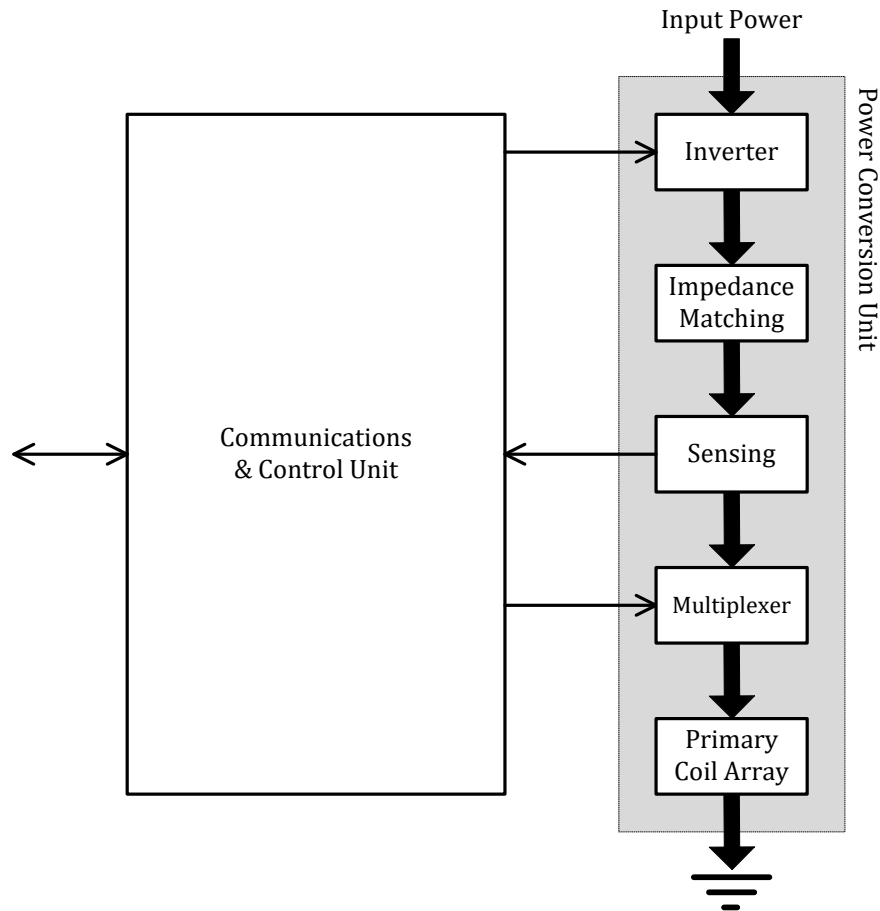

Figure 157. Functional block diagram of Power Transmitter design B5

The Power Conversion Unit on the right-hand side of Figure 157 comprises the analog parts of the design. The design uses an array of partly overlapping Primary Coils to provide for Free Positioning. Depending on the position of the Power Receiver, the multiplexer connects and/or disconnects the appropriate Primary Coils. The impedance matching network forms a resonant circuit with the parts of the Primary Coil array that are connected. The sensing circuits monitor (amongst others) the Primary Cell current and voltage, and the inverter converts the DC input to an AC waveform that drives the Primary Coil array.

The Communications and Control Unit on the left-hand side of Figure 157 comprises the digital logic part of the design. This unit receives and decodes messages from the Power Receiver, configures the multiplexer to connect the appropriate parts of the Primary Coil array, executes the relevant power control algorithms and protocols, and drives the inverter to control the amount of power provided to the Power Receiver. The Communications and Control Unit also interfaces with the other subsystems of the Base Station, e.g. for user interface purposes.

2.3.5.1 Mechanical details

Power Transmitter design B5 includes a Primary Coil array as defined in Section 2.3.5.1.1, Shielding as defined in Section 2.3.5.1.2, and an Interface Surface as defined in Section 2.3.5.1.3.

2.3.5.1.1 Primary Coil array

The Primary Coil array consists of partly overlapping square shaped planar coils. Figure 158(a) shows a top view of a single Primary Coil, which consists of a bifilar trace that runs through 11 square shaped turns in a single layer of a PCB. Another realization of a single Primary Coil is to construct it from litz wire having 24 strands of no. 40 AWG (0.08 mm diameter), or equivalent. Figure 158(b) shows a top view of such wire-wound Primary Coil. Table 103 lists the relevant parameters of the coils shown in Figure 158.

Figure 158. Top view of PCB and wire-wound Primary Coil of Power Transmitter design B5

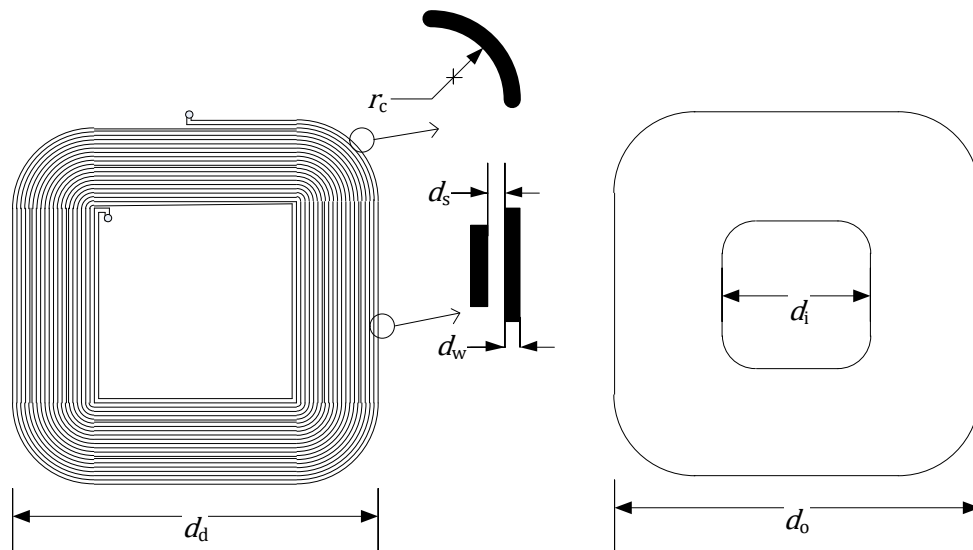

Table 103. Primary Coil parameters of Power Transmitter design B5

Parameter	Symbol	Value
<i>Litz wire based Primary Coil</i>		
Outer diameter	d_o	$45.0^{+0.5}_{-1.0}$ mm
Inner diameter	d_i	$18.6^{±0.3}$ mm
Number of turns	N	11
<i>PCB based Primary Coil</i>		
Outer diameter	d_d	$45^{±0.4}$ mm
Track width	d_w	$0.42^{±0.03}$ mm
Track width plus spacing	$d_w + d_s$	$0.6^{±0.03}$ mm
Corner rounding*	r_c	$9^{±1}$ mm
Number of turns	N	11

* Value applies to the outermost winding.

The Primary Coil array may be constructed from PCB-coils, wire-wound coils or any combination thereof (hybrid). Power Transmitter design B5 enables one-dimensional freedom of positioning. For that purpose the Primary Coils are placed in a row, such that there is an overlap of approximately two-thirds of the area. Each Primary Coil (except for the Primary Coils at both ends of the Primary Coil array) overlaps with two Primary Coils in different layers. Figure 159 shows the layout of the Primary Coil array. Figure 160 shows the layered structure of the Primary Coil array in the case of a PCB only implementation, a litz wire only implementation and a hybrid PCB-litz wire implementation. Table 104 lists the relevant parameters of the Primary Coil array. Any layer of the PCB—if present—may contain functionality other than, or in addition to, the Primary Coils. If such other functionality is present, that functionality shall not affect the inductance values of the Primary Coils.

Figure 159. Top view (a) and cross section (b) of the Primary Coil array of Power Transmitter design B5.

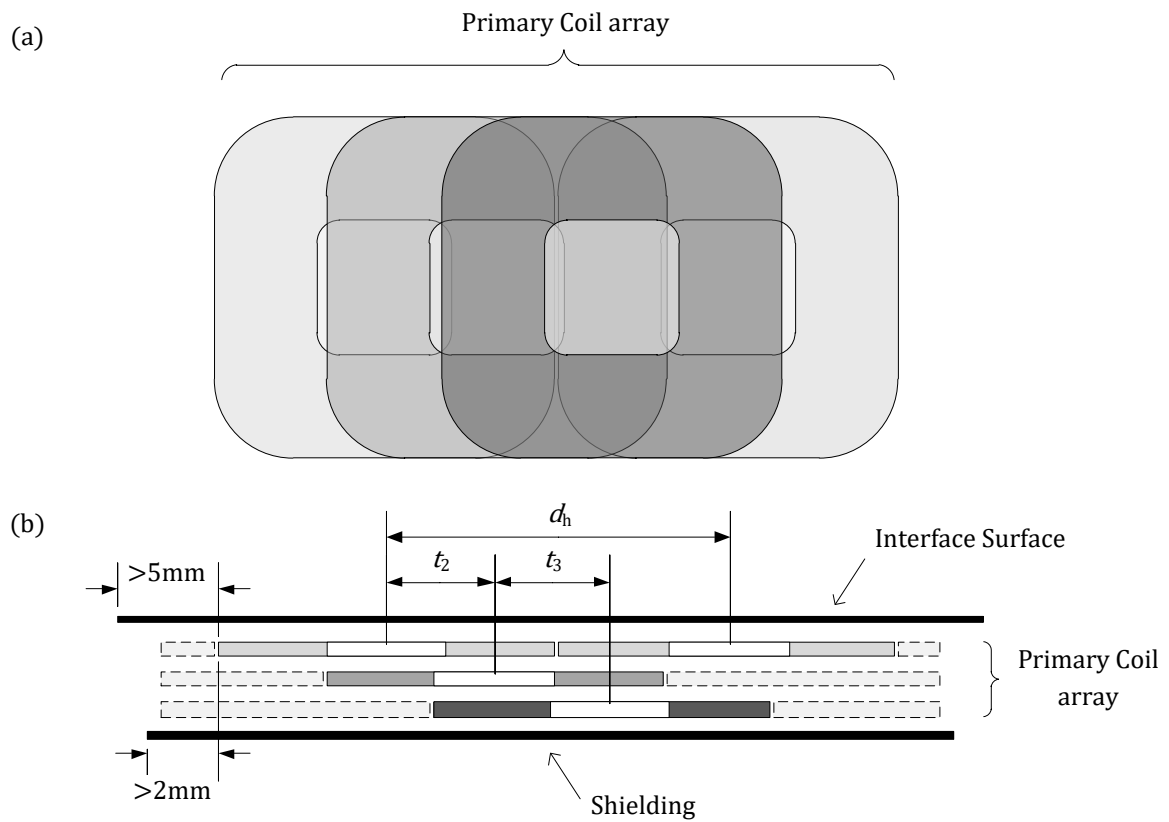

Figure 160. Layered structure of the Primary Coil array

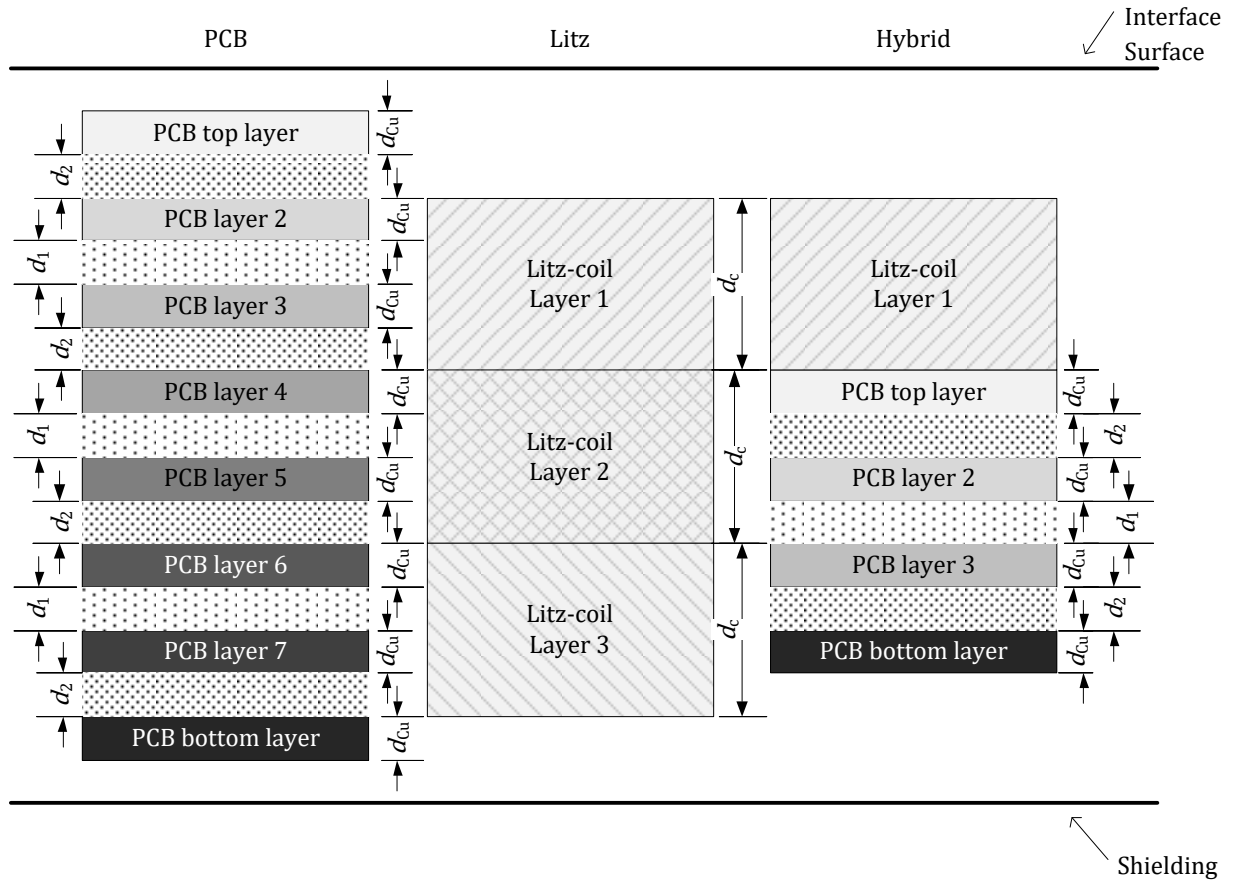

Table 104. Primary Coil array parameters of Power Transmitter design B5

Parameter	Symbol	Value
Center-to-center distance	d_h	$46.5^{\pm 0.2}$ mm
Offset 2 nd layer array	t_2	$15.5^{\pm 0.1}$ mm
Offset 3 rd layer array	t_3	$15.5^{\pm 0.1}$ mm
Litz-layer thickness	d_c	$0.4^{+0.1}_{-0.05}$ mm
PCB-copper thickness	d_{Cu}	$0.07^{\pm 0.015}$ mm
Dielectric thickness 1	d_{d1}	$0.088^{+0.15}_0$ mm
Dielectric thickness 2	d_{d2}	$0.126^{\pm 0.039}$ mm

2.3.5.1.2 Shielding

As shown in Figure 159, Transmitter design B5 employs Shielding to protect the Base Station from the magnetic field that is generated in the Primary Coil array. The Shielding should be Ni-Zn or Mn-Zn ferrite and should be at least 0.5 mm thick. The Shielding extends to at least 2 mm beyond the outer edges of the Primary Coil array, and is placed at a distance of at most $d_s = 0.5$ mm below the Primary Coil array.

Figure 161. Primary Coil array assembly of Power Transmitter design B5

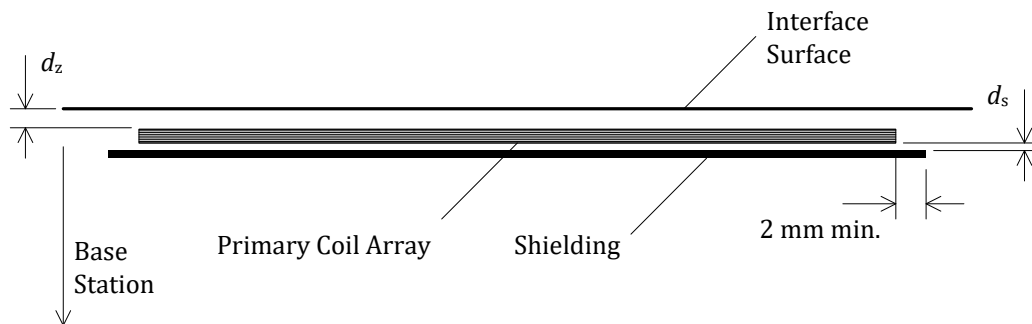

2.3.5.1.3 Interface Surface

As shown in Figure 161, the distance from the Primary Coil array to the Interface Surface of the Base Station is $d_z = 2^{+0.5}_{-0.25}$ mm, across the top face of the Primary Coil array. In addition, the Interface Surface extends at least 5 mm beyond the outer edges of the Primary Coil array.

2.3.5.2 Electrical details

As shown in Figure 162, Power Transmitter design B5 uses a full-bridge inverter to drive the Primary Coil array. In addition, Power Transmitter design B5 uses a multiplexer to select the position of the Active Area. The multiplexer shall configure the Primary Coil array in such a way that one, or two Primary Coils are connected—in parallel—to the driving circuit. The connected Primary Coils together constitute a Primary Cell. In the case that two Primary Coils are selected, these two Primary Coils shall have an overlap of two-thirds of the area of a single Primary Coil.

Figure 162. Electrical diagram (outline) of Power Transmitter design B5

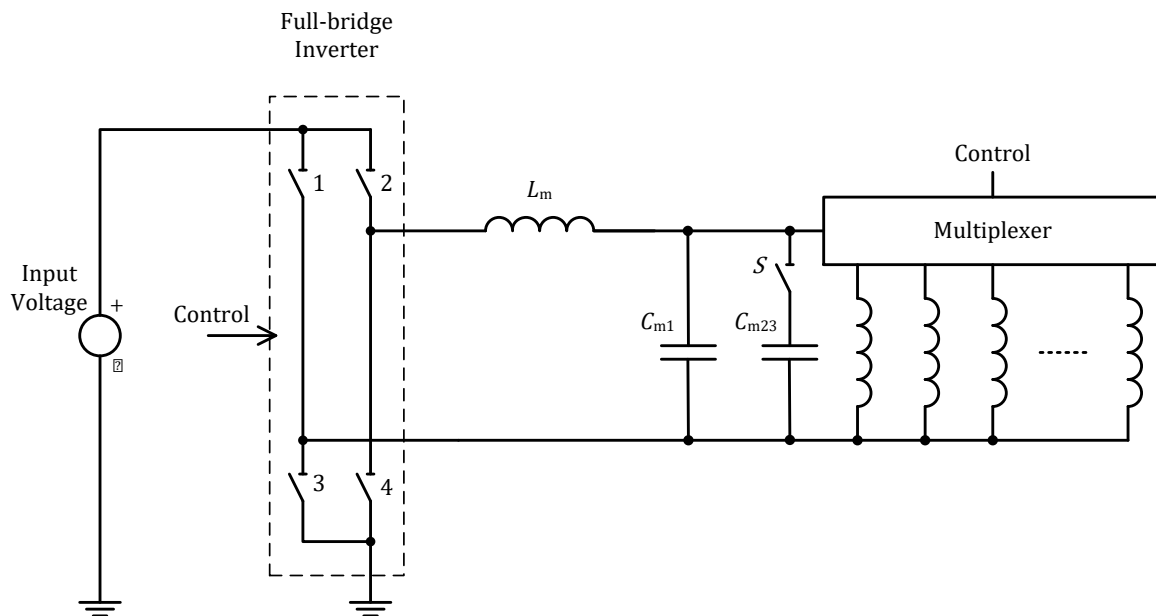

Within the Operating Frequency range $f_{op} = 96 \pm 2$ kHz, the assembly of Primary Coil array and Shielding has an inductance of 8.8 ± 1 μH for each individual Primary Coil in layer (a) (closest to the Interface Surface), 9.1 ± 1 μH for each individual Primary Coil in layer (b), and 9.5 ± 1 μH for each individual Primary Coil in layer (c) (closest to the Shielding). The capacitances and inductance in the impedance matching circuit are, respectively, $C_{m1} = 356 \pm 5\%$ nF, $C_{m23} = 82 \pm 5\%$ nF, and $L_m = 3.8 \pm 5\%$ μH . The switch S is open if the Primary Cell consists of a single Primary Coil; otherwise, the switch S is closed. The input voltage to the full-bridge inverter is $12 \pm 5\%$ V.

NOTE The voltage across the capacitance C_m can reach levels exceeding 36 V pk-pk.

Power Transmitter design B5 uses the phase difference between the control signals to two halves of the full-bridge inverter to control the amount of power that is transferred, see Figure 163. For this purpose, the range of the phase difference α is $0 \dots 180^\circ$ —with a larger phase difference resulting in a lower power transfer. In order to achieve a sufficient accurate adjustment of the power that is transferred, a type B5 Power Transmitter shall be able to control the phase difference with a resolution of 0.42° or better. When a type B5 Power Transmitter first applies a Power Signal (see the *Digital Ping* section in *Parts 1 and 2: Interface Definitions*), it shall use an initial phase difference of 120° .

Figure 163. Control signals to the inverter

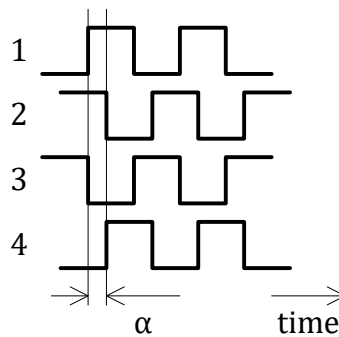

Control of the power transfer shall proceed using the PID algorithm, which is defined in the *Power transfer control* section in *Parts 1 and 2: Interface Definitions*. The controlled variable $v^{(i)}$ introduced in the definition of that algorithm represents the phase difference between the two halves of the full-bridge inverter. In order to guarantee sufficiently accurate power control, a type B5 Transmitter shall determine the amplitude of the current into the Primary Cell with a resolution of 5 mA or better. In addition to the PID algorithm, a type B5 Power Transmitter shall limit the current into the Primary Cell to at most 4 A RMS in the case that the Primary Cell consists of two Primary Coils, or at most 2 A RMS in the case that the Primary Cell consists of one Primary Coil. Finally, Table 105 provides the values of several parameters, which are used in the PID algorithm.

Table 105. Control parameters for power control

Parameter	Symbol	Value	Unit
Proportional gain	K_p	1	mA^{-1}
Integral gain	K_i	0	$\text{mA}^{-1}\text{ms}^{-1}$
Derivative gain	K_d	0	mA^{-1}ms
Integral term limit	M_i	N.A.	N.A.
PID output limit	M_{PID}	2,000	N.A.
Scaling factor	S_v	0.01	$^\circ$

2.3.5.3 Scalability

Power Transmitter Design B5 offers the same scalability options as Power Transmitter design B1. See Section 2.3.1.3.

2.3.6 Power Transmitter design B6

Figure 164 illustrates the functional block diagram of Power Transmitter design B6, which consists of two major functional units, namely a Power Conversion Unit and a Communications and Control Unit.

Figure 164. Functional block diagram of Power Transmitter design B6

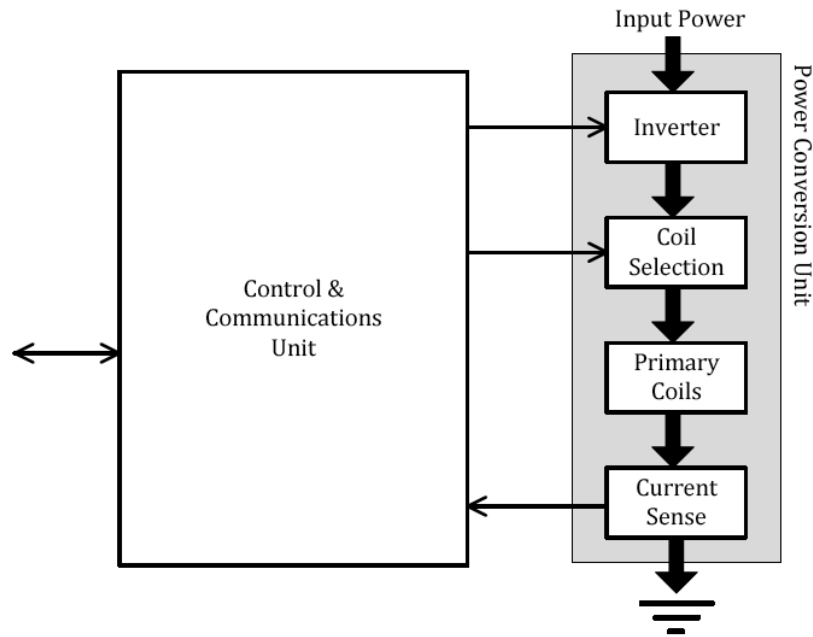

The Power Conversion Unit on the right-hand side of Figure 164 comprises the analog parts of the design. The design uses an array of partly overlapping Primary Coils to provide for Free Positioning. Depending on the position of the Power Receiver, the multiplexer connects and/or disconnects the appropriate Primary Coil(s). The resonance capacitor forms a resonant circuit with the parts of the Primary Coil array that are connected. The sensing circuits monitor (amongst others) the Primary Cell current and voltage, and the inverter converts the DC input to an AC waveform that drives the Primary Coil array.

The Communications and Control Unit on the left-hand side of Figure 164 comprises the digital logic part of the design. This unit receives and decodes messages from the Power Receiver, configures the multiplexer to connect the appropriate parts of the Primary Coil array, executes the relevant power control algorithms and protocols, and drives the inverter to control the amount of power provided to the Power Receiver. The Communications and Control Unit also interfaces with the other subsystems of the Base Station, e.g. for user interface purposes.

2.3.6.1 Mechanical details

Power Transmitter design B6 includes a Primary Coil array as defined in Section 2.3.6.1.1, Shielding as defined in Section 2.3.6.1.2, and an Interface Surface as defined in Section 2.3.6.1.3.

2.3.6.1.1 Primary Coil array

Each Primary Coil within the Primary Coil array is of the wire-wound type, and consists of 2 bifilar windings of each 11 turns of litz wire having 24 strands of no. 40 AWG (0.08 mm diameter), or equivalent². As shown in Figure 165, the Primary Coil has an oval shape and consists of a single layer. Table 106 lists the dimensions of the Primary Coil.

Figure 165. Primary coil of Power Transmitter design B6

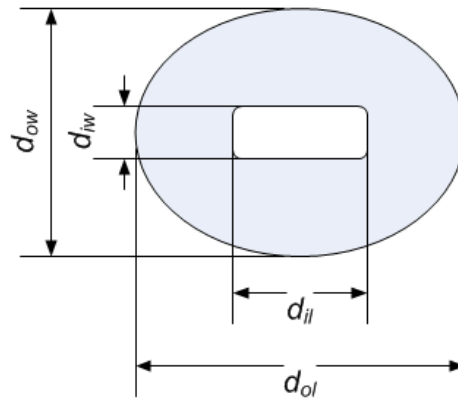

Table 106. Design parameters for Primary Coil array of Power Transmitter B6

Parameter	Symbol	Value
Outer length	d_{ol}	$45.0^{\pm 0.5}$ mm
Inner length	d_{il}	$18.4^{\pm 0.5}$ mm
Outer width	d_{ow}	$34.0^{+0.0}_{-1.0}$ mm
Inner width	d_{iw}	$7.2^{\pm 0.5}$ mm
Litz layer thickness	dC	$0.65^{\pm 0.3}$ mm
Number of turns per layer	N	11 turns
Number of layers	-	1

Power Transmitter design B6 contains at least two Primary Coils and allows for 1-dimensional freedom of positioning. All adjacent Primary Coils are placed with their long sides alongside each other with a displacement of $d_o = 17.0^{+2.0}_{-0.0}$ mm between their centers, such that there is an overlap of about 50% of the area. Figure 166 shows the functional arrangement of coils in the Primary Coil array. See also Table 106 for details of the parameters.

² One equivalent example is a single winding of 11 turns of Litz wire having 96 strands of no. 40 AWG (0.08mm diameter)

Figure 166. Arrangement of coils in the Primary Coil array of Power Transmitter B6

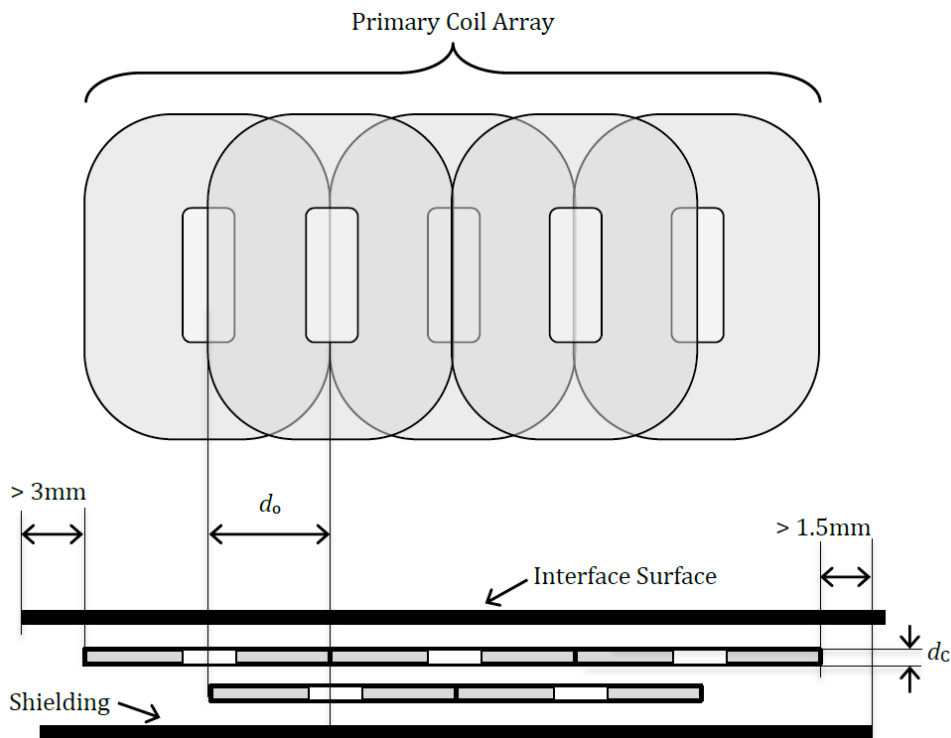

The Communications & Control Unit of a single Power Transmitter selects 1 or 2 coils from the array to form a Primary Cell for power transfer when a Power Receiver is positioned on the Active Area. In the case where 2 coils are selected, these 2 coils shall have an overlap.

2.3.6.1.2 Shielding

As shown in Figure 166, Transmitter design B6 employs Shielding to protect the Base Station from the magnetic field that is generated in the Primary Coil array. The Shielding should be Ni-Zn or Mn-Zn ferrite and should be at least 0.5 mm thick. The Shielding extends to at least 1.5 mm beyond the outer edges of the Primary Coil array, and is placed at a distance of at most $d_s = 0.5\text{ mm}$ below the Primary Coil array.

Figure 167. Primary Coil array assembly of Power Transmitter design B6

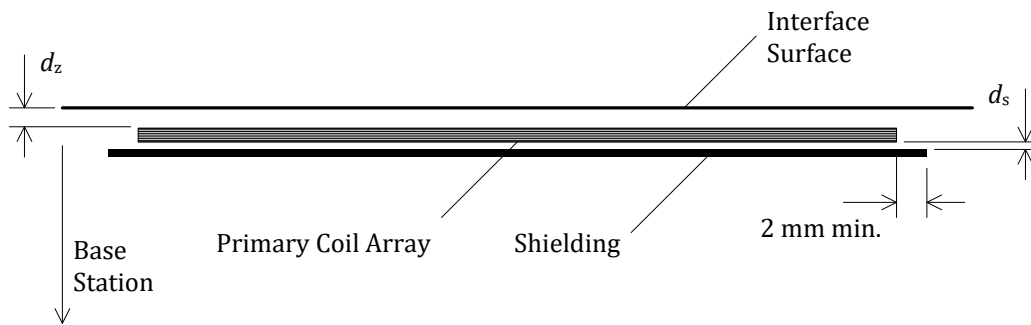

2.3.6.1.3 Interface Surface

As shown in Figure 167, the distance from the Primary Coil array to the Interface Surface of the Base Station is $d_z = 2^{+0.25}_{-0.5}$ mm, across the top face of the Primary Coil array. In addition, the Interface Surface extends at least 3 mm beyond the outer edges of the Primary Coil array.

2.3.6.2 Electrical details

As shown in Figure 168, Power Transmitter design B6 uses a full-bridge inverter to drive the Primary Coil array. In addition, Power Transmitter design B6 uses a multiplexer to select the position of the Active Area. The multiplexer shall configure the Primary Coil array in such a way that one or two (overlapping; see Section 2.3.6.1.1) Primary Coils are connected—in parallel—to the driving circuit. The connected Primary Coil(s) together constitute a Primary Cell.

Figure 168. Electrical diagram (outline) of Power Transmitter design B6

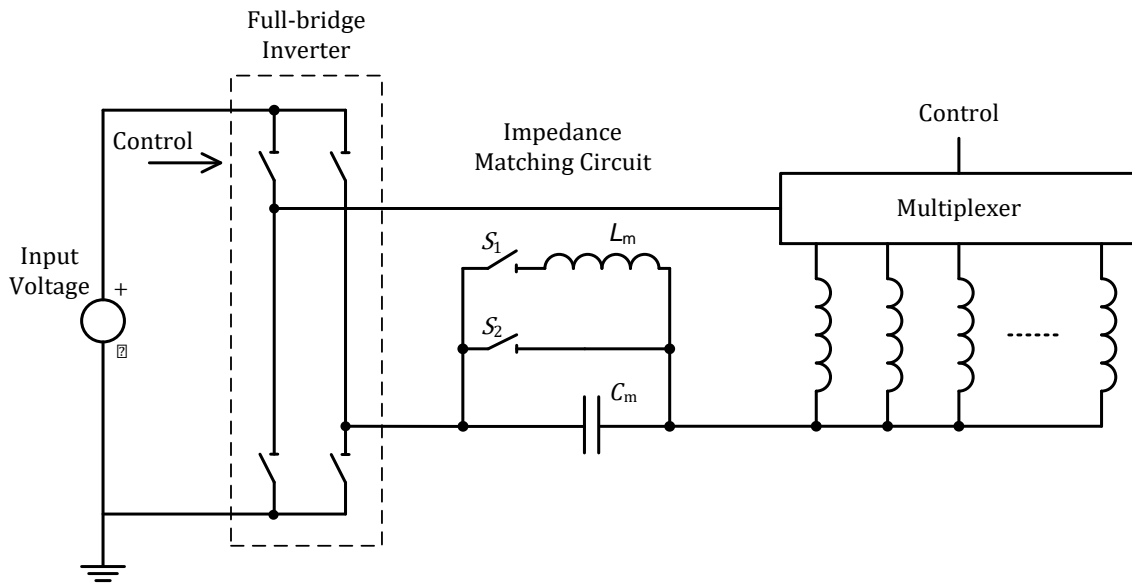

Within the Operating Frequency range $f_{op} = 125 \dots 135$ kHz, the assembly of Primary Coil array and Shielding has an inductance of $5.8^{\pm 0.5}$ μH for each individual Primary Coil in layer (a) (closest to the Interface Surface), and $6.2^{\pm 0.5}$ μH for each individual Primary Coil in layer (b) (closest to the Shielding). The capacitance in the impedance matching circuit is $C_m = 1000^{\pm 5\%}$ nF. The inductance in the impedance matching circuit is $L_m = 1$ μH . The input voltage to the full-bridge inverter is $5^{\pm 5\%}$ V.

NOTE The voltage across the capacitance C_m can reach levels exceeding 25V pk-pk.

Switches S_1 and S_2 may be used to change the impedance the inverter sees when driving the Primary Cell, allowing the inverter to drive the Primary Cell at Operating Points that are more efficient (i.e. requiring less current). During normal operation both switches should be open. However, during a Digital Ping switch S_1 should be closed and switch S_2 should be open. Basically there are three combinations of switch positions as indicated in the Table 107 below. The initial Operating Point of the Power Transmitter occurs during a Digital Ping. In this situation a low amount of power is transferred to allow any Power Receiver to initialize and respond. Switch S_2 may be used to provide a smooth transition from the damped inductive state to the resonant state (both switches open) and ensures that there is no magnetizing current flowing through L_m when switch S_1 is turned off.

Table 107. Power Transmitter design B6 switch configurations

S_1	S_2	Inverter state	Comment
Closed	Open	Damped inductive	Digital Ping—low power
Any	Closed	Normal inductive	Transition—medium power
Open	Open	Resonant	Power Transfer—high power

Power Transmitter design B6 uses the phase difference between the control signals to two halves of the full-bridge inverter to control the amount of power that is transferred, see Figure 169. For this purpose, the range of the phase difference α is $0\dots180^\circ$ —with a larger phase difference resulting in a higher power transfer. In order to achieve a sufficient accurate adjustment of the power that is transferred, a type B6 Power Transmitter shall be able to control the phase difference with a resolution of 0.42° or better. When a type B6 Power Transmitter first applies a Power Signal (see the *Digital Ping* section in *Parts 1 and 2: Interface Definitions*), it shall use an initial phase difference of 180° and switch S_1 closed and switch S_2 open.

Figure 169. Control signals to the inverter

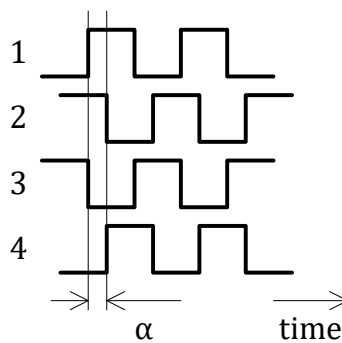

Control of the power transfer shall proceed using the PID algorithm, which is defined in the *Power transfer control* section in *Parts 1 and 2: Interface Definitions*. The controlled variable $v^{(i)}$ introduced in the definition of that algorithm represents the phase difference between the two halves of the full-bridge inverter. In order to guarantee sufficiently accurate power control, a type B6 Transmitter shall determine the amplitude of the current into the Primary Cell with a resolution of 5 mA or better. In addition to the PID algorithm, a type B6 Power Transmitter shall limit the current into the Primary Cell to at most 5 A RMS in the case that the Primary Cell consists of two Primary Coils, or at most 3 A RMS in the case that the Primary Cell consists of one Primary Coil. Finally, Table 108 provides the values of several parameters, which are used in the PID algorithm.

Table 108. Control parameters for power control

Parameter	Symbol	Value	Unit
Proportional gain	K_p	1	mA^{-1}
Integral gain	K_i	0	$\text{mA}^{-1}\text{ms}^{-1}$
Derivative gain	K_d	0	mA^{-1}ms
Integral term limit	M_I	N.A.	N.A.
PID output limit	M_{PID}	2,000	N.A.
Scaling factor	S_v	0.01	°

2.3.6.3 Scalability

Sections 2.3.6.1 and 2.3.6.2 define the mechanical and electrical details of Power Transmitter design B6. As defined in Section 2.1, a type B6 Power Transmitter serves a single Power Receiver only. In order to serve multiple Power Receivers simultaneously, a Base Station may contain multiple type B6 Power Transmitters. As shown in Figure 170, these Power Transmitters may share the Primary Coil array and multiplexer. However, each individual Power Transmitter shall have a separately controllable inverter, resonance circuit, and means to determine the Primary Cell current, as defined in Section 2.3.6.2. In addition, the multiplexer shall ensure that it does not connect multiple inverters to any individual Primary Coil.

Figure 170. Multiple type B6 Power Transmitters sharing a multiplexer and Primary Coil array

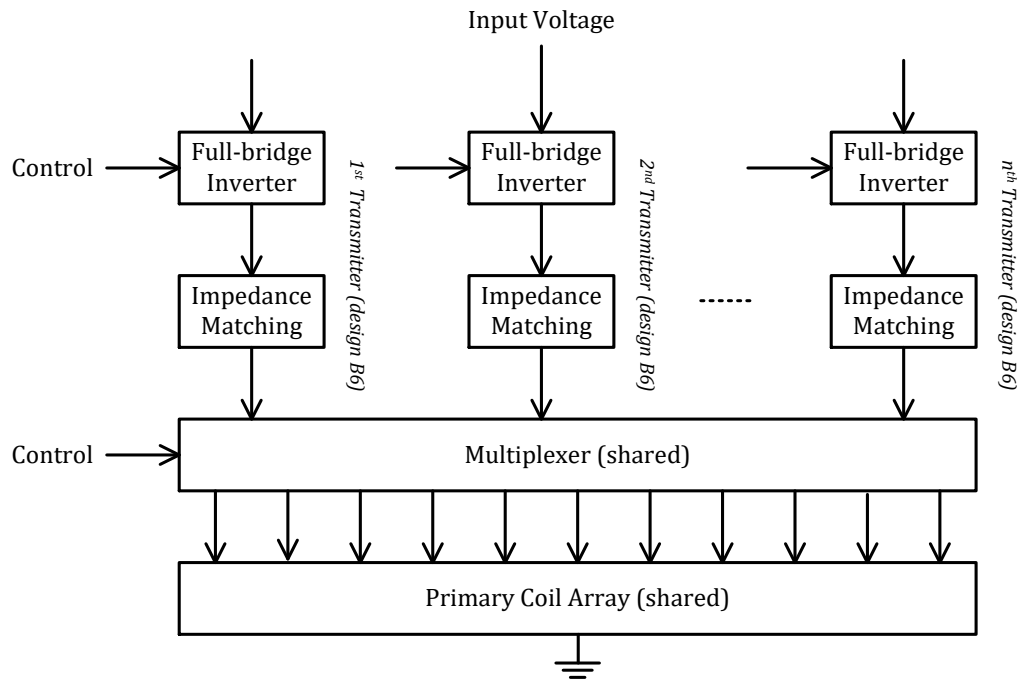

2.3.7 Power Transmitter design B7

Figure 171 illustrates the functional block diagram of Power Transmitter design B7, which consists of two major functional units, namely a Power Conversion Unit and a Communications and Control Unit.

Figure 171. Functional block diagram of Power Transmitter design B7

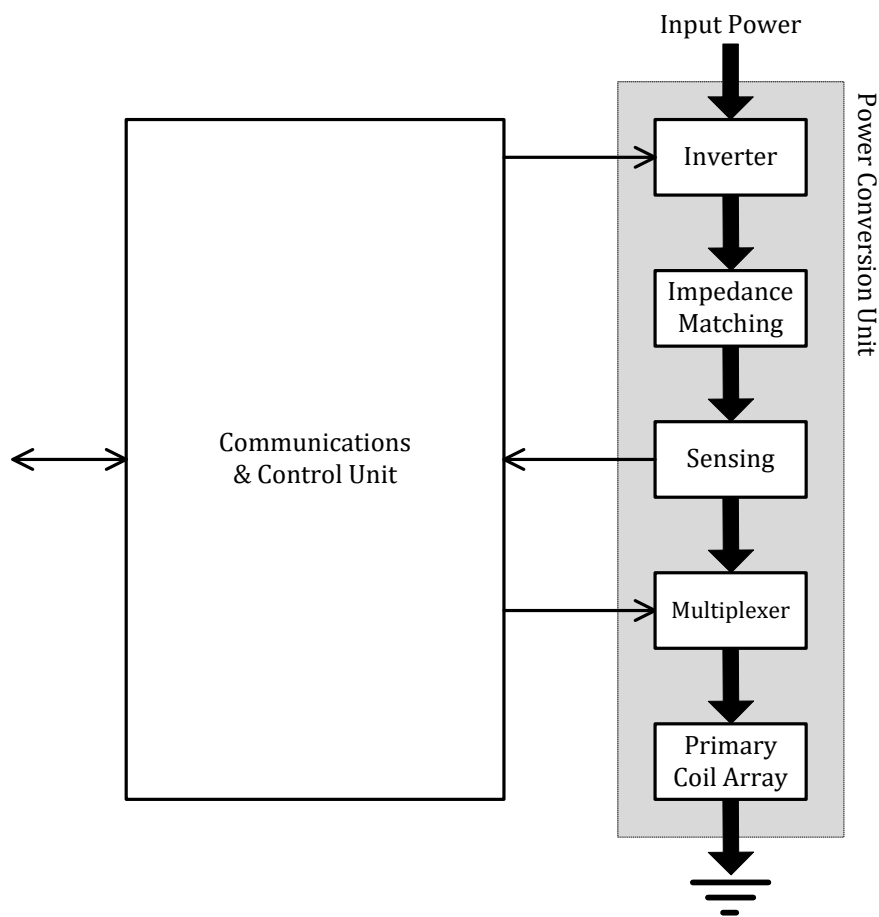

The Power Conversion Unit on the right-hand side of Figure 171 comprises the analog parts of the design. The design uses an array of partly overlapping Primary Coils to provide for Free Positioning. Depending on the position of the Power Receiver, the multiplexer connects and/or disconnects the appropriate Primary Coil(s). The impedance matching network forms a resonant circuit with the parts of the Primary Coil array that are connected. The sensing circuits monitor (amongst others) the Primary Cell current and voltage, and the inverter converts the DC input to an AC waveform that drives the Primary Coil array.

The Communications and Control Unit on the left-hand side of Figure 171 comprises the digital logic part of the design. This unit receives and decodes messages from the Power Receiver, configures the multiplexer to connect the appropriate parts of the Primary Coil array, executes the relevant power control algorithms and protocols, and drives the inverter to control the amount of power provided to the Power Receiver. The Communications and Control Unit also interfaces with the other subsystems of the Base Station, e.g. for user interface purposes.

2.3.7.1 Mechanical details

Power Transmitter design B7 includes a Primary Coil array as defined in Section 2.3.7.1.1, Shielding as defined in Section 2.3.7.1.2, and an Interface Surface as defined in Section 2.3.7.1.3.

2.3.7.1.1 Primary Coil array

The Primary Coil array consists of partly-overlapping, rectangular-shaped planar coils. In order to keep the inductance of each coil similar in the final assembly there are two coils specified for this transmitter type, Primary Coil A and Primary Coil B. On the left side of Figure 172 is a top view of Primary Coil A (left), which consists of a 17 AWG (1.2 mm diameter) wire that runs through 9 rectangular-shaped turns in a single layer. On the right is a top view of Primary Coil B, which consists of a 17 AWG (1.2 mm diameter) wire that runs through 10 rectangular-shaped turns in a single layer. Another realization of a single Primary Coil A or B is to construct it from litz wire having 105 strands of no. 40 AWG (0.08 mm diameter), or equivalent. Table 109 lists the relevant parameters of the coils shown in Figure 172.

NOTE Primary Coil B can be constructed from Primary Coil A by adding one inner turn, conversely, Primary Coil A can be constructed from Primary Coil B by removing one inner turn.

In this Primary Coil array the coils closest to the shielding shall be according to Primary Coil A, and the coils closest to the Interface Surface shall be according to Primary Coil B. Moreover, a transmitter execution that uses only one Primary Coil shall use Primary Coil A.

Figure 172. Top view of Primary Coil A (left) and Primary Coil B (right) of Power Transmitter design B7

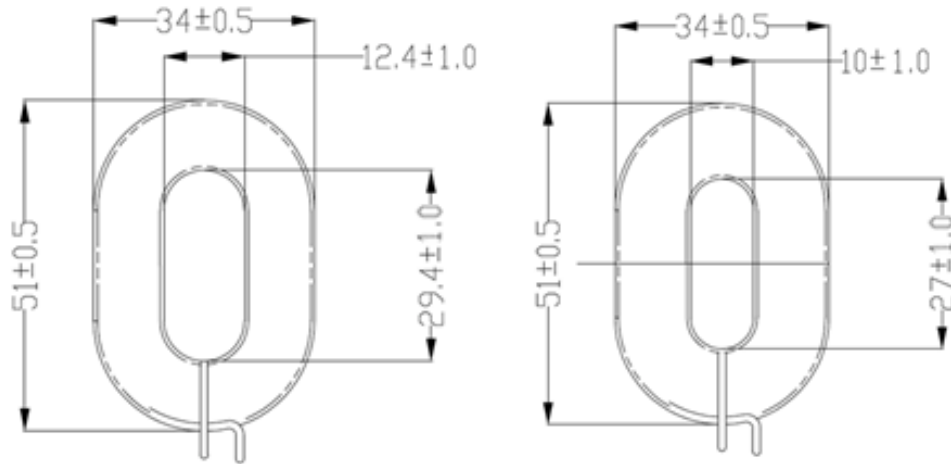

Table 109. Primary Coil parameters of Power Transmitter design B7

Parameter	Symbol	Value
<i>Primary Coil A (closest to the shielding)</i>		
Outer width	w_o	$34.0^{+0.5}_{-0.5}$ mm
Outer length	l_o	$51.0^{+0.5}_{-0.5}$ mm
Inner width	w_i	$12.4^{+1.0}_{-1.0}$ mm
Inner length	l_i	$29.4^{+1.0}_{-1.0}$ mm
Number of turns	N	9
<i>Primary Coil B (closest to Interface Surface)</i>		
Outer width	w_o	$34.0^{+0.5}_{-0.5}$ mm
Outer length	l_o	$51.0^{+0.5}_{-0.5}$ mm
Inner width	w_i	$10.0^{+1.0}_{-1.0}$ mm
Inner length	l_i	$27.0^{+1.0}_{-1.0}$ mm
Number of turns	N	10

Power Transmitter design B7 enables one-dimensional freedom of positioning. For that purpose the Primary Coils are placed in a row, such that there is an overlap of approximately 50% of the area. Each Primary Coil (except for an execution that uses only one Primary Coil) overlaps with one other Primary Coils in a different layer. Figure 173 shows the layout of an example execution of the Primary Coil array using four Primary Coils. Table 110 lists the relevant parameters of the Primary Coil array.

Figure 173. Example of Power Transmitter design B7 in a 4-coil execution

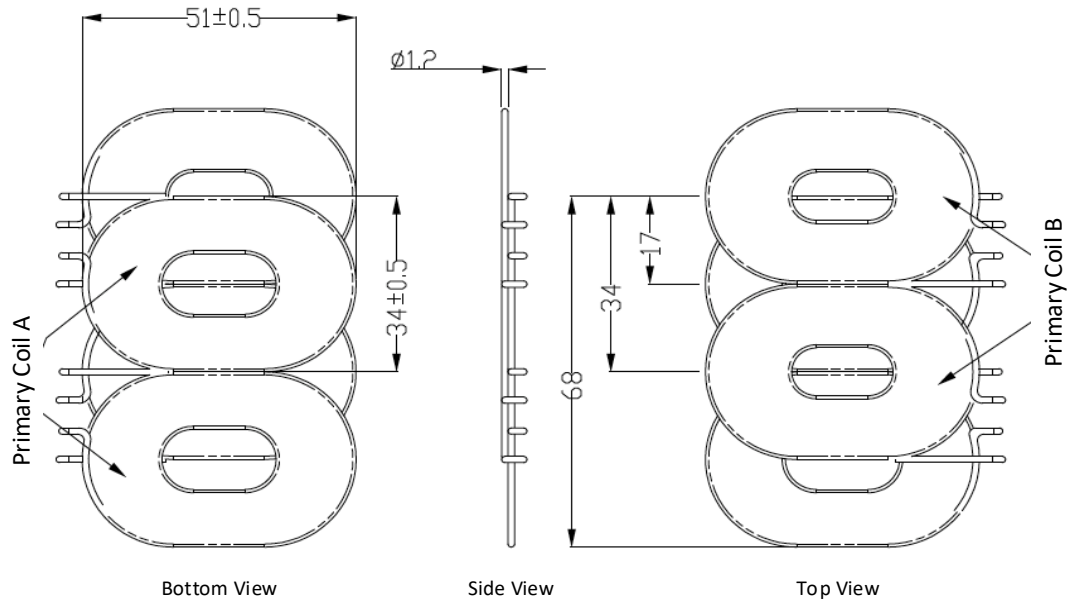

Table 110. Primary Coil array parameters of Power Transmitter design B7

Parameter	Symbol	Value
Center-to-center distance	d_h	$34.0^{\pm 0.5}$ mm
Offset 2 nd layer array	t_2	$17.0^{\pm 0.5}$ mm
Litz-layer thickness	d_c	$1.2^{\pm 0.5}$ mm

2.3.7.1.2 Shielding

As shown in Figure 174, Transmitter design B7 employs Shielding to protect the Base Station from the magnetic field that is generated in the Primary Coil array. The Shielding should be Ni-Zn or Mn-Zn ferrite and should be at least 0.5 mm thick. The Shielding extends to at least 1 mm beyond the outer edges of the Primary Coil array, and is placed at a distance of at most $d_s = 0.5$ mm below the Primary Coil array.

Figure 174. Primary Coil array assembly of Power Transmitter design B7

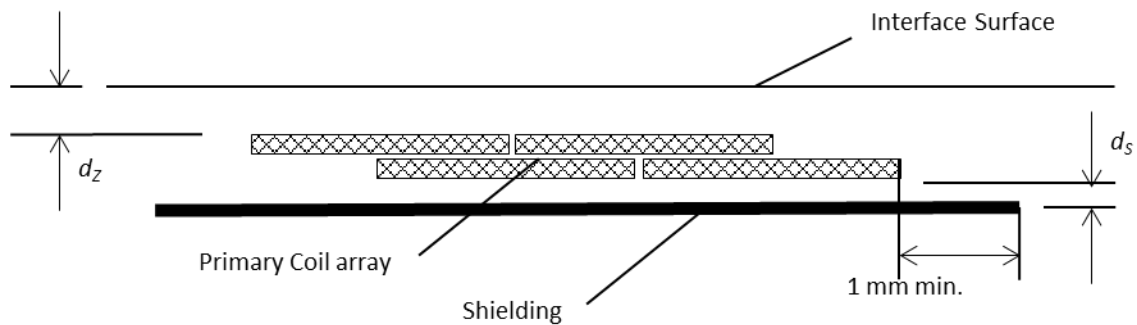

2.3.7.1.3 Interface Surface

As shown in Figure 174, the distance from the Primary Coil array to the Interface Surface of the Base Station is $d_z = 2^{\pm 0.5}$ mm, across the top face of the Primary Coil array. In addition, the Interface Surface extends at least 2 mm beyond the outer edges of the Primary Coil array.

2.3.7.2 Electrical details

As shown in Figure 175, Power Transmitter design B7 uses a full-bridge inverter to drive the Primary Coil array. In addition, Power Transmitter design B7 uses a multiplexer to select the position of the Active Area. The multiplexer shall configure the Primary Coil array in such a way that one, or two Primary Coils are connected—in parallel—to the driving circuit. The connected Primary Coils together constitute a Primary Cell. In the case that two Primary Coils are selected, these two Primary Coils shall have an overlap of approximately 50% of the area of a single Primary Coil.

Figure 175. Electrical diagram (outline) of Power Transmitter design B7

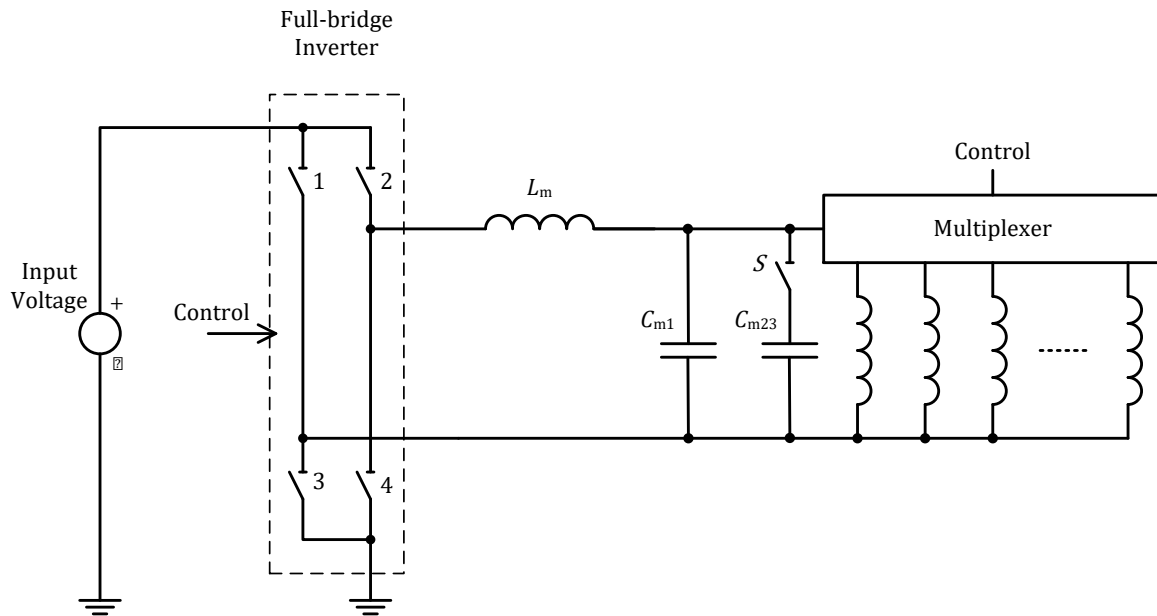

Within the Operating Frequency range $f_{op} = 115^{\pm 5}$ kHz, the assembly of Primary Coil array and Shielding has an inductance of $6.1^{\pm 0.6}$ μ H for each individual Primary Coil. The capacitances and inductance in the impedance matching circuit are, respectively, $C_{m1} = 300^{\pm 5\%}$ nF, $C_{m23} = 100^{\pm 5\%} - 300^{\pm 5\%}$ nF, $L_m = 3.8^{\pm 5\%}$ μ H. The switch S is open if the Primary Cell consists of a single Primary Coil; otherwise, the switch S is closed. The input voltage to the full-bridge inverter is $15^{\pm 5\%}$ V.

NOTE The voltage across the capacitance C_m can reach levels exceeding 40 V pk-pk.

Power Transmitter design B7 uses the phase difference between the control signals to two halves of the full-bridge inverter to control the amount of power that is transferred, see Figure 176. For this purpose, the range of the phase difference α is $0 \dots 180^\circ$ —with a larger phase difference resulting in a lower power transfer. In order to achieve a sufficient accurate adjustment of the power that is transferred, a type B7 Power Transmitter shall be able to control the phase difference with a resolution of 0.42° or better. When a type B7 Power Transmitter first applies a Power Signal (see the *Digital Ping* section in *Parts 1 and 2: Interface Definitions*), it shall use an initial phase difference of 150° .

Figure 176. Control signals to the inverter

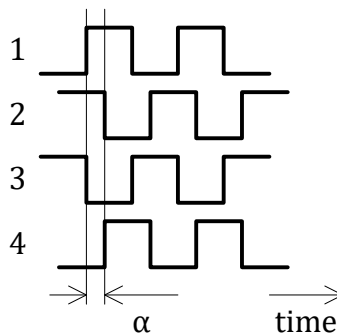

Control of the power transfer shall proceed using the PID algorithm, which is defined in the *Power transfer control* section in *Parts 1 and 2: Interface Definitions*. The controlled variable $v^{(i)}$ introduced in the definition of that algorithm represents the phase difference between the two halves of the full-bridge inverter. In order to guarantee sufficiently accurate power control, a type B7 Transmitter shall determine the amplitude of the current into the Primary Cell with a resolution of 5 mA or better. In addition to the PID algorithm, a type B7 Power Transmitter shall limit the current into the Primary Cell to at most 4 A RMS in the case that the Primary Cell consists of two Primary Coils, or at most 3 A RMS in the case that the Primary Cell consists of one Primary Coil. Finally, Table 111 provides the values of several parameters that are used in the PID algorithm.

Table 111. Power control parameters for Power Transmitter design B7

Parameter	Symbol	Value	Unit
Proportional gain	K_p	1	mA^{-1}
Integral gain	K_i	0	$\text{mA}^{-1}\text{ms}^{-1}$
Derivative gain	K_d	0	mA^{-1}ms
Integral term limit	M_i	N.A.	N.A.
PID output limit	M_{PID}	2,000	N.A.
Scaling factor	S_v	0.01	$^\circ$

2.3.7.3 Scalability

Power Transmitter Design B7 offers the same scalability options as Power Transmitter design B1. See Section 2.3.1.3.

2.4 Extended Power Profile Power Transmitter designs

This Section 2.4 defines all type MP-A Power Transmitter designs in the Extended Power Profile. In addition to the definitions in this section, each Power Transmitter design shall implement the relevant parts of the protocols and communications interface defined in *Parts 1 and 2: Interface Definitions*.

2.4.1 Power Transmitter design MP-A1

Figure 177 illustrates the functional block diagram of Power Transmitter design MP-A1. This design consists of two major functional units, namely a Power Conversion Unit and a Communications and Control Unit.

Figure 177. Functional block diagram of Power Transmitter design MP-A1

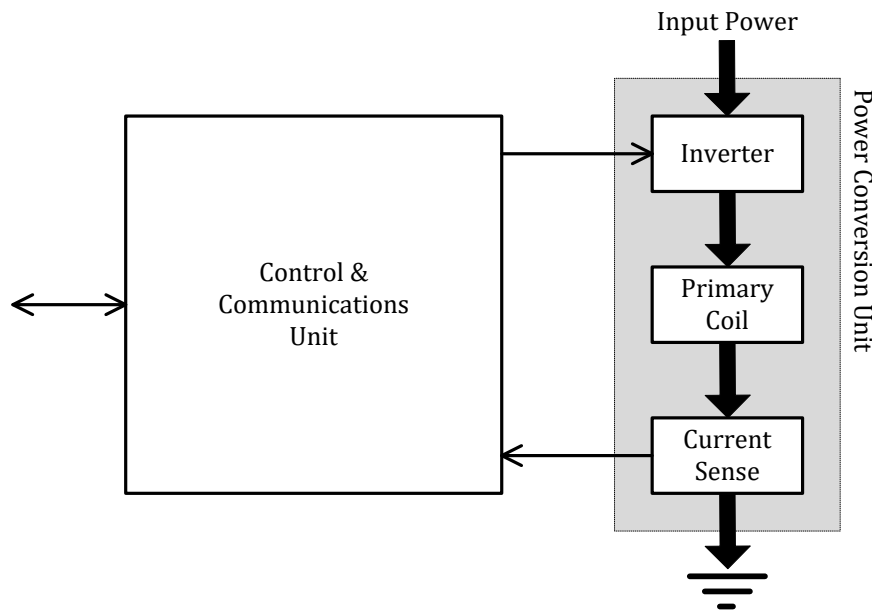

The Power Conversion Unit on the right-hand side of Figure 177 comprises the analog parts of the design. The inverter converts the DC input to an AC waveform that drives a resonant circuit consisting of the Primary Coil plus a series capacitor. Finally, the current sense monitors the Primary Coil current.

The Communications and Control Unit on the left-hand side of Figure 177 comprises the digital logic part of the design. This unit receives and decodes messages from the Power Receiver, executes the relevant power control algorithms and protocols, and drives the frequency of the AC waveform to control the power transfer. The Communications and Control Unit also interfaces with other subsystems of the Base Station, e.g. for user interface purposes.

2.4.1.1 Mechanical details

This section defines the Primary Coil, the Shielding, the Interface Surface, and the alignment aid for Power Transmitter design MP-A1.

2.4.1.1.1 Primary Coil

The Primary Coil of the MP-A1 design is identical to the Primary Coil of the type A10 Power Transmitter defined in Section 0.

2.4.1.1.2 Shielding

As shown in Figure 178, Shielding protects the Base Station from the magnetic field that is generated in the Primary Coil. The Shielding should be Ni-Zn or Mn-Zn ferrite and should be at least 2.0 mm thick. The Shielding extends to at least 2 mm beyond the outer diameter of the Primary Coil, and is placed below the Primary Coil at a distance of at most $d_s = 1.0$ mm.

Figure 178. Primary Coil assembly of Power Transmitter design MP-A1

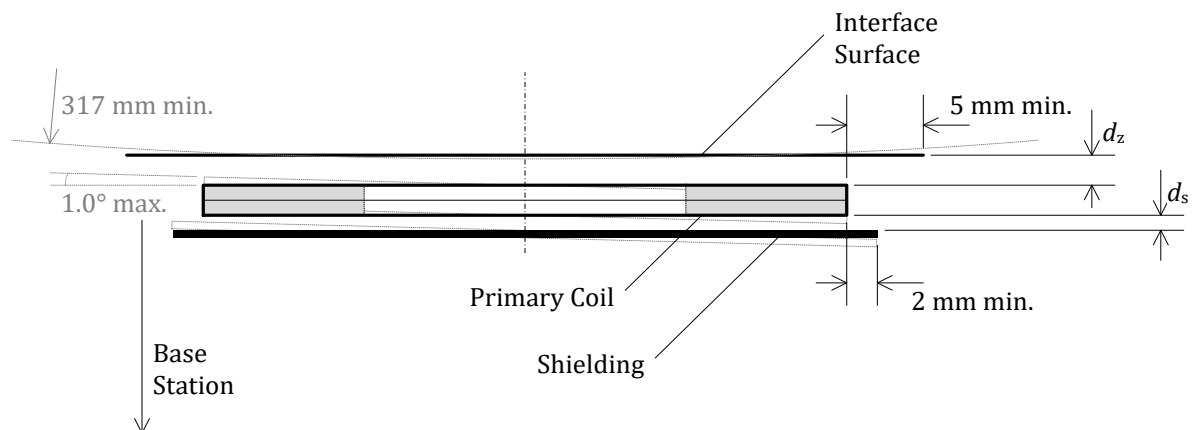

2.4.1.1.3 Interface Surface

As shown in Figure 178, the distance from the Primary Coil to the Interface Surface of the Base Station is $d_z = 2^{+0.5}_{-0.25}$ mm, across the top face of the Primary Coil. In addition, the Interface Surface of the Base Station extends at least 5 mm beyond the outer diameter of the Primary Coil.

NOTE This Primary-Coil-to-Interface-Surface distance implies that the tilt angle between the Primary Coil and a flat Interface Surface is at most 1.0°. Alternatively, in case of a non-flat Interface Surface, this Primary-Coil-to-Interface-Surface distance implies a radius of curvature of the Interface Surface of at least 317 mm, centered on the Primary Coil. See Figure 178.

2.4.1.1.4 Alignment aid

The user manual of a Base Station containing a type MP-A1 Power Transmitter shall provide information about the location of its Active Area(s).

For the best user experience, it is recommended to employ at least one user feedback mechanism during Mobile Device positioning to help alignment.

NOTE Examples of Base Station alignment aids to assist the user positioning of the Mobile Device include:

- A marked Interface Surface to indicate the location of the Active Area(s)—e.g. a logo or other visual marking, lighting, etc.
- A visual feedback display—e.g. by means of illuminating an LED to indicate proper alignment.
- An audible or tactile feedback mechanism.

2.4.1.1.5 Inter-coil separation

If the Base Station contains multiple type MP-A1 Power Transmitters, the Primary Coils of any pair of those Power Transmitters shall have a center-to-center distance of at least 50 mm.

2.4.1.2 Electrical details

As shown in Figure 179, Power Transmitter design MP-A1 uses a full-bridge inverter to drive the Primary Coil and a series capacitance. Within the Operating Frequency range specified below, the assembly of Primary Coil and Shielding has a self-inductance $L_p = 24^{\pm 10\%}$ μH . The value of the series capacitance is $C_p = 100^{\pm 5\%}$ nF.

NOTE Near resonance, the voltage developed across the series capacitance can reach levels exceeding 200 V pk-pk.

Power Transmitter design MP-A1 uses the Operating Frequency and the phase difference of the full-bridge inverter's driving signals (see Figure 180), or uses the Operating Frequency and duty cycle of the half-bridge inverter's driving signals (see Figure 181) in order to control the amount of power that is transferred. For this purpose, the Operating Frequency range of the inverter is $f_{op} = 110$ kHz to 205 kHz with a driving signal phase difference of $\alpha = 0^\circ$ to 135° or a duty cycle of $t_{on}/t_{period} = 10\%$ to 50% . A higher Operating Frequency, higher phase, or lower duty cycle will result in the transfer of a lower amount of power. In order to achieve a sufficiently accurate adjustment of the amount of power that is transferred, a type MP-A1 Power Transmitter shall control the Operating Frequency with a minimum resolution of:

- $0.01 \cdot f_{op} - 0.7$ kHz for f_{op} in the 110 kHz to 175 kHz range;
- $0.015 \cdot f_{op} - 1.58$ kHz for f_{op} in the 175 kHz to 205 kHz range;

In addition, a type MP-A1 Power Transmitter shall control the driving-signal phase difference with a resolution of 0.18° or better. Moreover, a type MP-A1 Power Transmitter shall control the driving-signal duty cycle with a resolution of 0.1% or better.

When a type MP-A1 Power Transmitter first applies a Power Signal (Digital Ping), it shall use an initial input voltage to the half-bridge inverter of $19^{\pm 1}$ V and an initial Operating Frequency range of 170 kHz to 180 kHz and a duty cycle of 50%.

Control of the power transfer shall proceed using the PID algorithm, which is defined in *Parts 1 and 2: Interface Definitions*. The controlled variable $v^{(i)}$ introduced in the definition of that algorithm represents the Operating Frequency, operating duty cycle, or operating phase difference depending on the required power of the Power Receiver. In order to guarantee sufficiently accurate power control, a type MP-A1 Power Transmitter shall determine the amplitude of the Primary Cell current—which is equal to the Primary Coil current—with a resolution of 7 mA or better. Finally, Table 112, Table 113, Table 114, and Table 115 provide the values of several parameters that are used in the PID algorithm.

The type MP-A1 Power Transmitter shall handle the different control methodologies as follows.

- At an Operating Frequency of 205 kHz, the Power Transmitter shall operate in half-bridge mode, using duty cycle control with a range of 10% to 50%.
- At Operating Frequencies between 160 kHz and 205 kHz, the Power Transmitter shall operate in half-bridge mode at 50% duty cycle, using frequency control.
- At an Operating Frequency of 160 kHz, the Power Transmitter shall operate in full-bridge mode with a phase difference of 0° to 135° .
- At Operating Frequencies below 160 kHz, the Power Transmitter shall operate in full-bridge mode with a phase difference of 0° using frequency control.

When the Power Transmitter reaches the 160 kHz transition point, it shall

- switch from half-bridge mode to full-bridge mode at a 135° phase difference if moving down in Operating Frequency, or
- switch from full-bridge mode at a 135° phase difference to half-bridge mode if moving up in Operating Frequency.

If the Power Transmitter reaches the 160 kHz transition point in the middle of a PID control loop, the Power Transmitter shall terminate the control loop and wait for subsequent Control Error Packets.

Figure 179. Electrical diagram (outline) of Power Transmitter design MP-A1

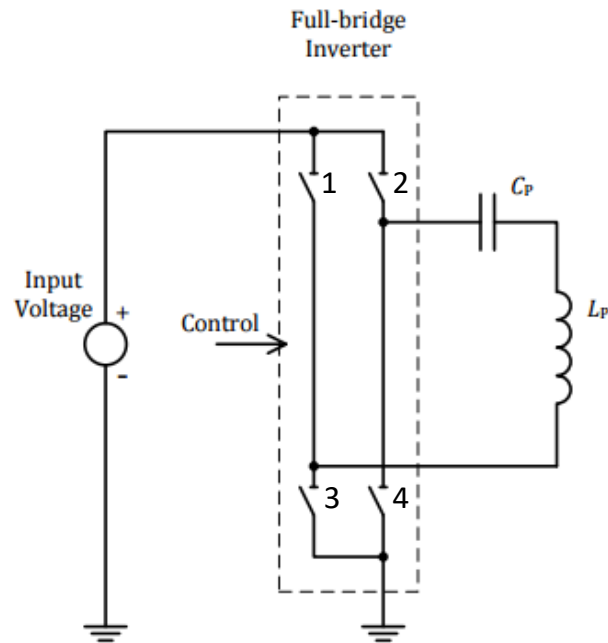

Table 112. PID parameters for Operating Frequency control

Parameter	Symbol	Value	Unit
Proportional gain	K_p	10	mA^{-1}
Integral gain	K_i	0.05	$\text{mA}^{-1}\text{ms}^{-1}$
Derivative gain	K_d	0	mA^{-1}ms
Integral term limit	M_i	3,000	N.A.
PID output limit	M_{PID}	20,000	N.A.

Figure 180. Phase control signals to Full Bridge inverter

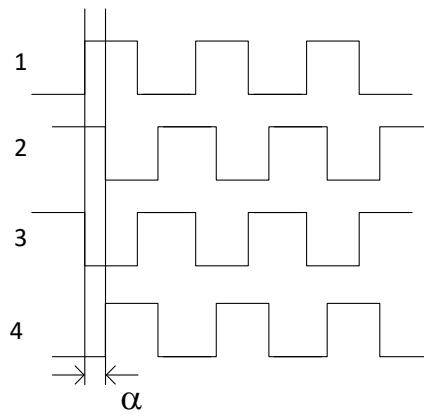

Figure 181. Duty control signals to Half Bridge inverter

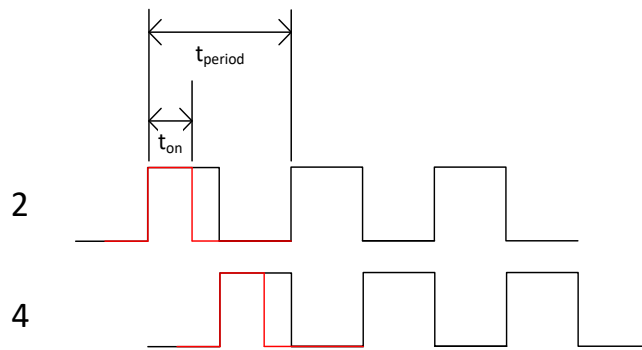

Table 113. Operating Frequency dependent scaling factor

Frequency Range [kHz]	Scaling Factor S_V [Hz]
110 to 130	1
130 to 140	1.5
140 to 160	2
160 to 180	3
180 to 205	5

Table 114. PID parameters for phase control

Parameter	Symbol	Value	Unit
Proportional gain	K_p	1	mA^{-1}
Integral gain	K_i	0.01	$\text{mA}^{-1}\text{ms}^{-1}$
Derivative gain	K_d	0	mA^{-1}ms
Integral term limit	M_I	3,000	N.A.
PID output limit	M_{PID}	20,000	N.A.
Scaling factor	S_V	0.036	°

Table 115. PID parameters for duty cycle control

Parameter	Symbol	Value	Unit
Proportional gain	K_p	10	mA^{-1}
Integral gain	K_i	1	$\text{mA}^{-1}\text{ms}^{-1}$
Derivative gain	K_d	0	mA^{-1}ms
Integral term limit	M_I	3,000	N.A.
PID output limit	M_{PID}	20,000	N.A.
Scaling factor	S_V	-0.01	%

2.4.1.3 Information interface

The Not Res Sens Bit in the Configuration Packet shall be set to ZERO.

2.4.2 Power Transmitter design MP-A2

Figure 182 illustrates the functional block diagram of Power Transmitter design MP-A2. This design consists of two major functional units, namely a Power Conversion Unit and a Communications and Control Unit.

Figure 182. Functional block diagram of Power Transmitter design MP-A2

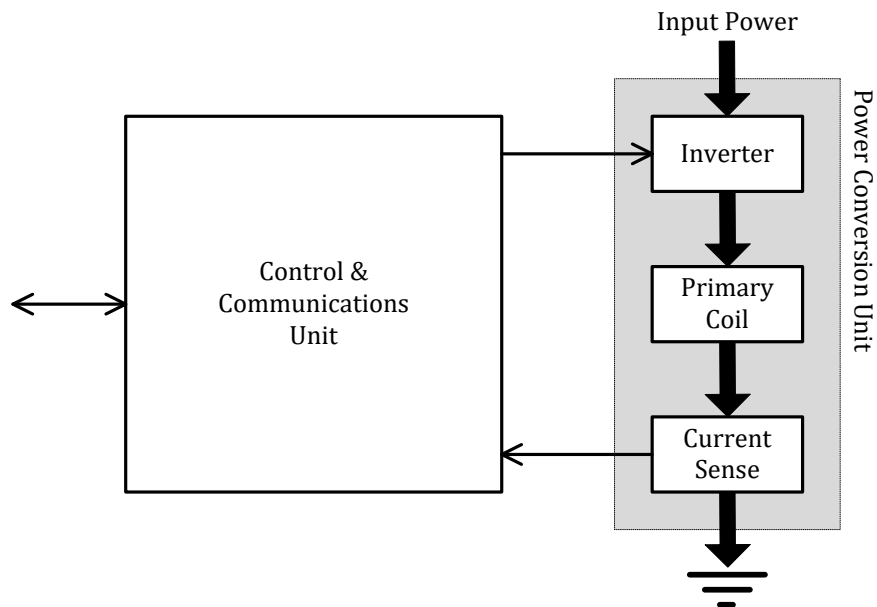

The Power Conversion Unit on the right-hand side of Figure 182 comprises the analog parts of the design. The inverter converts the DC input to an AC waveform that drives a resonant circuit consisting of the Primary Coil plus a series capacitor. Finally, the current sense monitors the Primary Coil current.

The Communications and Control Unit on the left-hand side of Figure 182 comprises the digital logic part of the design. This unit receives and decodes messages from the Power Receiver, executes the relevant power control algorithms and protocols, and drives the frequency of the AC waveform to control the power transfer. The Communications and Control Unit also interfaces with other subsystems of the Base Station, e.g. for user interface purposes.

2.4.2.1 Mechanical details

This section defines the single Primary Coil, the Shielding, the Interface Surface and the alignment aid for Power Transmitter design MP-A2.

2.4.2.1.1 Primary Coil

The Primary Coil is of the wire-wound type, and consists of no. 17 AWG litz wire having 105 strands of no. 40 AWG (0.08 mm diameter), or equivalent. As shown in Figure 183 the Primary Coil has a rectangular shape and consists of a single layer. Table 116 lists the dimensions and other parameters of the Primary Coil.

Figure 183. Primary Coil parameters of Power Transmitter design MP-A2

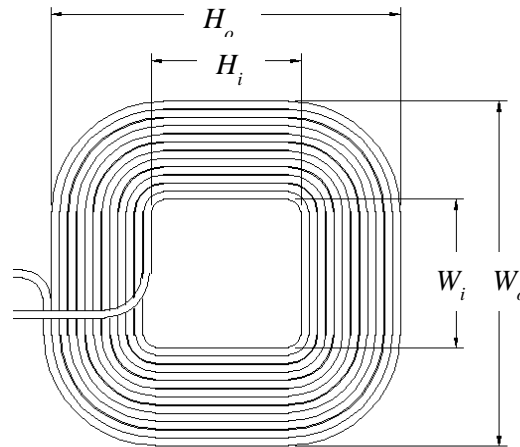

Table 116. Primary Coil parameters of Power Transmitter design MP-A2

Parameter	Symbol	Value
Outer height	H_o	$48^{\pm 0.5}$ mm
Inner height	H_i	$19^{\pm 0.5}$ mm
Outer width	W_o	$48^{\pm 0.5}$ mm
Inner width	W_i	$19^{\pm 0.5}$ mm
Thickness	d_c	$1.1^{\pm 0.3}$ mm
Number of turns per layer	N	12
Number of layers	-	1

2.4.2.1.2 Shielding

As shown in Figure 184, a soft-magnetic material protects the Base Station from the magnetic field that is generated in the Primary Coil. The Shielding should be Ni-Zn or Mn-Zn ferrite and should be at least 1.5 mm thick. The Shielding extends to at least 2.5 mm beyond the outer rectangle of the Primary Coil, and is placed below the Primary Coil at a distance of at most $d_s = 1.0$ mm.

Figure 184. Primary Coil assembly of Power Transmitter design MP-A2

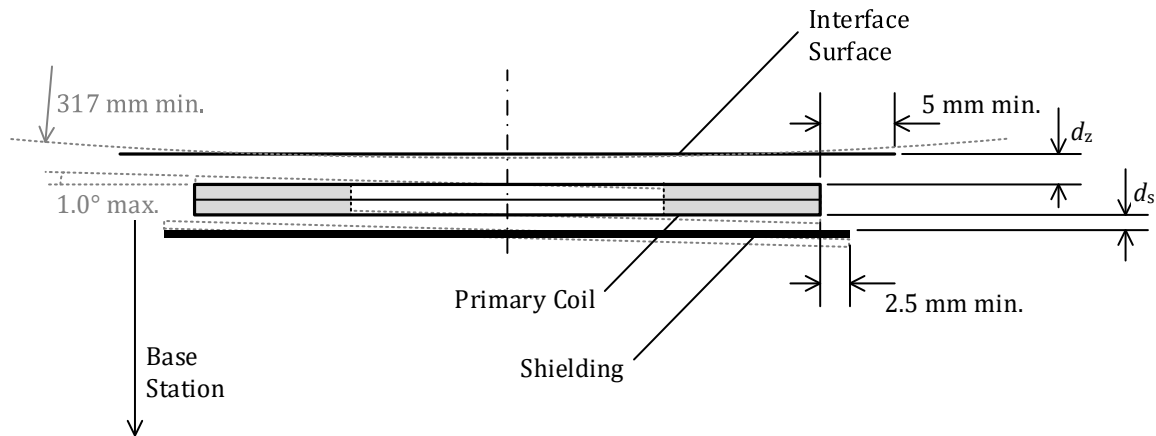

2.4.2.1.3 Interface Surface

As shown in Figure 184, the distance from the Primary Coil to the Interface Surface of the Base Station is $d_z = 3.0^{+0.5}_{-0.25}$ mm across the top face of the Primary Coil. In addition, the Interface Surface of the Base Station extends at least 5 mm beyond the outer diameter of the Primary Coil.

NOTE This Primary-Coil-to-Interface-Surface distance implies that the tilt angle between the Primary Coil and a flat Interface Surface is at most 1.0°. Alternatively, in case of a non-flat Interface Surface, this Primary-Coil-to-Interface-Surface distance implies a radius of curvature of the Interface Surface of at least 317 mm, centered on the Primary Coil. See Figure 184.

2.4.2.1.4 Alignment aid

The user manual of a Base Station containing a type MP-A2 Power Transmitter shall provide information about the location of its Active Area(s).

For the best user experience, it is recommended to employ at least one user feedback mechanism during Mobile Device placement to help alignment.

NOTE Examples of Base Station alignment aids to assist the user placement of the Mobile Device include:

- A marked Interface Surface to indicate the location of its Active Area(s)—e.g. a logo or other visual marking, lighting, etc.
- A visual feedback display—e.g. by means of illuminating an LED to indicate proper alignment.
- An audible or tactile feedback mechanism.

2.4.2.1.5 Inter-coil separation

If the Base Station contains multiple type MP-A2 Power Transmitters, the Primary Coils of any pair of those Power Transmitters shall not overlap.

2.4.2.2 Electrical details

As shown in Figure 185 and Figure 186, Power Transmitter design MP-A2 uses half-bridge and full-bridge inverter topologies to drive the Primary Coil and a series capacitance. Within the Operating Frequency range specified below, the assembly of Primary Coil and Shielding, has a self-inductance $L_p = 10.0^{\pm 10\%}$ μH . The value of the series capacitance is $C_p = 247^{\pm 5\%}$ nF. The input voltage to the inverter is $12^{\pm 1}$ V.

NOTE Near resonance, the voltage developed across the series capacitance can reach levels exceeding 200 V pk-pk.

Power Transmitter design MP-A2 uses a combination of the Operating Frequency and the duty cycle of the Power Signal to control the amount of power that is transferred. For this purpose, the Operating Frequency range of the inverter is $f_{op} = 110$ kHz to 145 kHz. The duty cycle of the full-bridge inverter is 40% to 50% if $f_{op} = 110$ kHz to 145 kHz and is 5% to 50% at $f_{op} = 145$ kHz. A higher Operating Frequency or a lower duty cycle will result in the transfer of a lower amount of power. In order to achieve a sufficiently accurate adjustment of the amount of power that is transferred, a type MP-A2 Power Transmitter shall control the Operating Frequency with a minimum resolution of $0.007 \cdot f_{op} - 0.5$ kHz for f_{op} in the 110 kHz to 145 kHz range. In addition, a Type MP-A2 Power Transmitter shall control the duty cycle of the Power Signal with a resolution of 0.1% or better.

When a type MP-A2 Power Transmitter first applies a Power Signal (Digital Ping), it shall use the half-bridge inverter topology with an initial input voltage of $12^{\pm 1}V$ and an initial Operating Frequency in the range of 135 kHz to 145 kHz and a duty cycle of 50%. If a type MP-A2 Power Transmitter establishes the Power Transfer Contract at the end of the *negotiation* phase (see the *Power Transmitter perspective* section in *Parts 1 and 2: Interface Definitions*) with a Maximum Power greater than 5 W, it shall change its inverter to use the full-bridge topology after receiving the first Control Error Packet. The Initial Operating Frequency of the full-bridge inverter topology is in the range of 135 kHz to 145 kHz and the initial duty cycle is 20%.

Control of the power transfer shall proceed using the PID algorithm that is defined in *Parts 1 and 2: Interface Definitions*. The controlled variable $v^{(i)}$ introduced in the definition of that algorithm represents the Operating Frequency or the duty cycle. In order to guarantee sufficiently accurate power control, a type MP-A2 Power Transmitter shall determine the amplitude of the Primary Coil current with a resolution of 7 mA or better. Finally, Table 117, Table 118, and Table 119 provide the values of the parameters that are used in the PID algorithm for the full-bridge inverter topology; Table 120, Table 121, and Table 122 provide the same parameters for the half-bridge inverter topology.

Figure 185. Electrical diagram (outline) of Power Transmitter design MP-A2 (full-bridge topology)

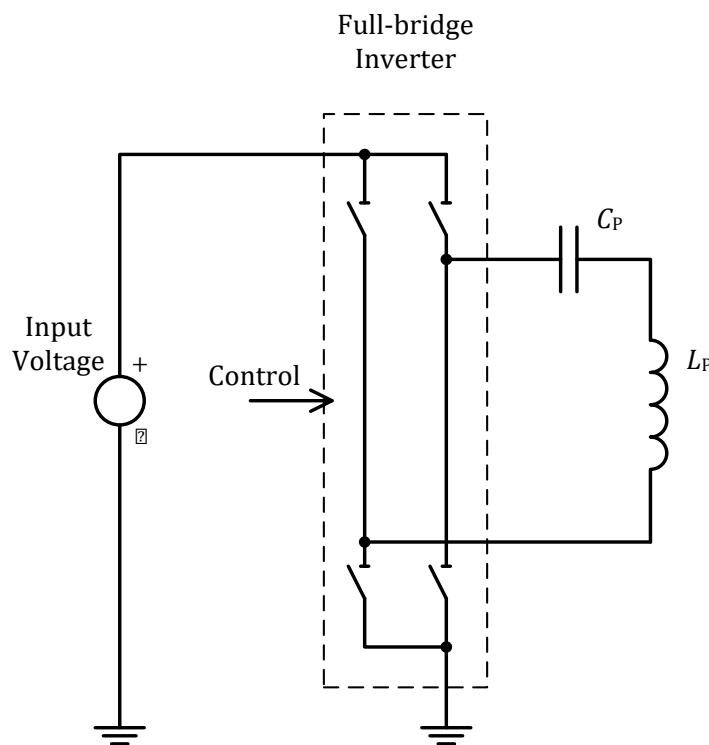

Table 117. PID parameters for Operating Frequency control design MP-A2 (full-bridge topology)

Parameter	Symbol	Value	Unit
Proportional gain	K_p	2	mA^{-1}
Integral gain	K_i	0.01	$\text{mA}^{-1}\text{ms}^{-1}$
Derivative gain	K_d	0	mA^{-1}ms
Integral term limit	M_i	500	N.A.
PID output limit	M_{PID}	5,000	N.A.

Table 118. Operating Frequency dependent scaling factor (full-bridge topology)

Frequency Range [kHz]	Scaling Factor S_V [Hz]
110 to 115	1.5
115 to 120	2
120 to 135	3
135 to 140	5

Table 119. PID parameters for duty control (full-bridge topology)

Parameter	Symbol	Value	Unit
Proportional gain	K_p	2	mA^{-1}
Integral gain	K_i	0.01	$\text{mA}^{-1}\text{ms}^{-1}$
Derivative gain	K_d	0	mA^{-1}ms
Integral term limit	M_i	500	N.A.
PID output limit	M_{PID}	5,000	N.A.
Scaling factor	S_V	-0.01	%

Table 120. Electrical diagram of Power Transmitter design MP-A2 (half-bridge topology)

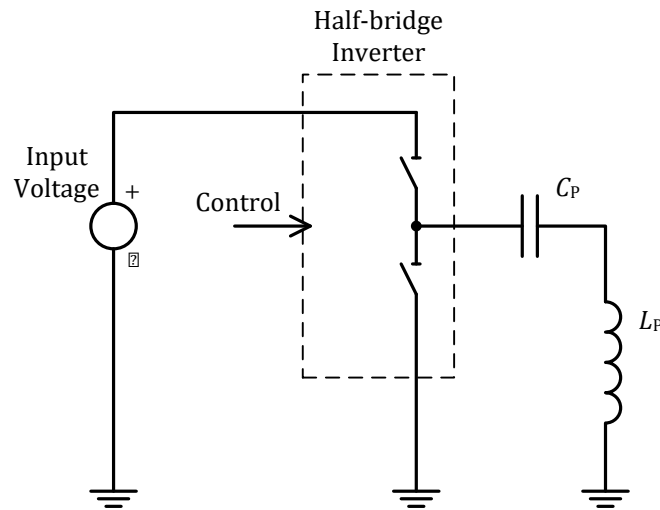

Table 121. PID parameters for Operating Frequency control (half-bridge topology)

Parameter	Symbol	Value	Unit
Proportional gain	K_p	5	mA^{-1}
Integral gain	K_i	0.02	$\text{mA}^{-1}\text{ms}^{-1}$
Derivative gain	K_d	0	mA^{-1}ms
Integral term limit	M_i	1,000	N.A.
PID output limit	M_{PID}	10,000	N.A.

Table 122. Operating Frequency dependent scaling factor (half-bridge topology)

Frequency Range [kHz]	Scaling Factor S_V [Hz]
110 to 115	1.5
115 to 120	2
120 to 135	3
135 to 140	5

Table 123. PID parameters for duty cycle control (half-bridge topology)

Parameter	Symbol	Value	Unit
Proportional gain	K_p	5	mA^{-1}
Integral gain	K_i	0.02	$\text{mA}^{-1}\text{ms}^{-1}$
Derivative gain	K_d	0	mA^{-1}ms
Integral term limit	M_I	1,000	N.A.
PID output limit	M_{PID}	10,000	N.A.
Scaling factor	S_V	-0.01	%

2.4.2.3 Information interface

The Not Res Sens Bit in the Configuration Packet shall be set to ZERO.

2.4.3 Power Transmitter design MP-A3

Figure 186 illustrates the functional block diagram of Power Transmitter design MP-A3. This design consists of two major functional units, namely a Power Conversion Unit and a Communications and Control Unit.

Figure 186. Functional block diagram of Power Transmitter design MP-A3

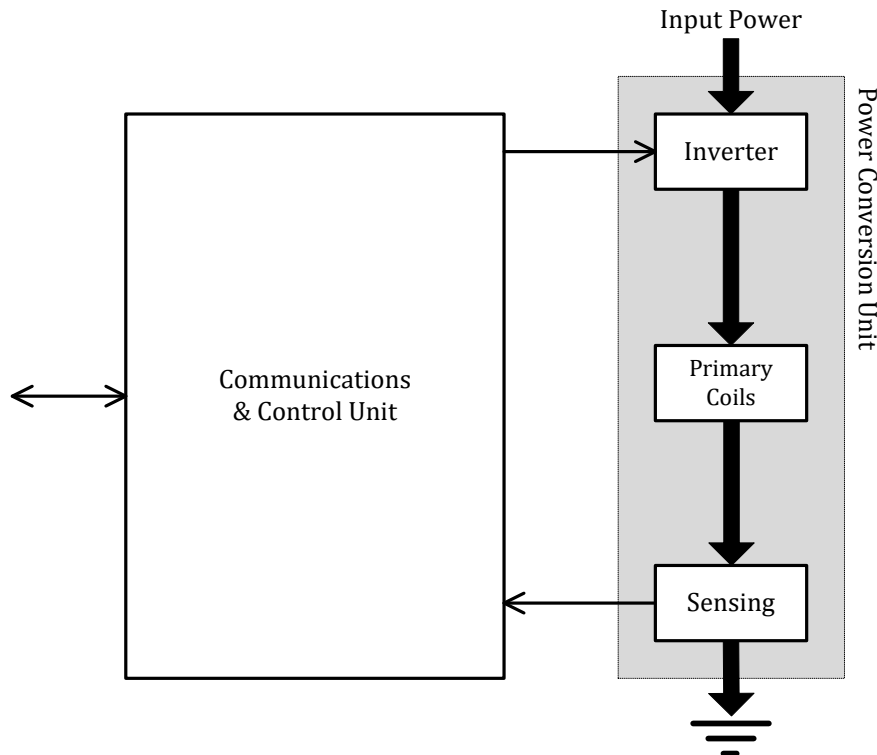

The Power Conversion Unit on the right-hand side of Figure 186 comprises the analog parts of the design. The inverter converts the DC input to an AC waveform that drives a resonant circuit consisting of the Primary Coil plus a series capacitor. Finally, the voltage and current sense monitors the Primary Coil voltage and current.

The Communications and Control Unit on the left-hand side of Figure 186 comprises the digital logic part of the design. The unit receives and decodes messages from the Power Receiver, executes the relevant power control algorithms and protocols, and drives the input power and frequency of the AC waveform to control the power transfer. The Communications and Control Unit also interfaces with other subsystems of the Base Station, e.g. for user interface purposes.

2.4.3.1 Mechanical details

Power Transmitter design MP-A3 includes one Primary Coil, Shielding, and an Interface Surface as defined in the subsections below.

2.4.3.1.1 Primary Coil

The Primary Coil is of the wire-wound type, and consists of no. 14 AWG litz wire having 140 strands of no. 38 AWG (0.1 mm diameter), or equivalent. As shown in Figure 187, the Primary Coil has a racetrack-like shape and consists of multiple layers. All layers are stacked with the same polarity. The dimensions of the Primary Coil are listed in Table 124.

Figure 187. Primary Coil of Power Transmitter design MP-A3

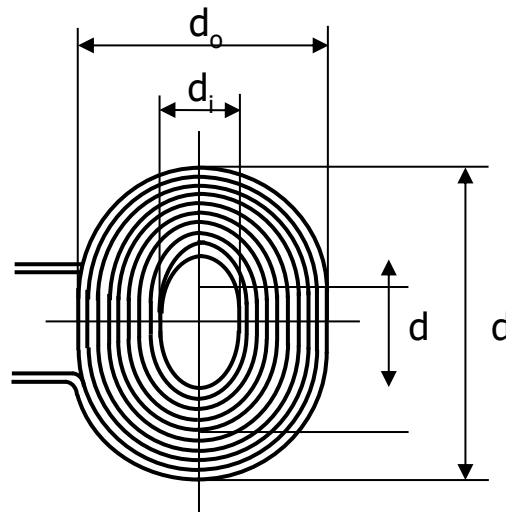

Table 124. Primary Coil parameters of Power Transmitter design MP-A3

Parameter	Symbol	Value
Outer length	d_{ol}	$42.8^{±2.0}$ mm
Inner length	d_{il}	$17.2^{±1.0}$ mm
Outer width	d_{ow}	$36.2^{±2.0}$ mm
Inner width	d_{iw}	$9.3^{±1.0}$ mm
Thickness	d_c	$3.8^{±0.5}$ mm
Number of turns per layer	N	8
Number of layers	-	2

2.4.3.1.2 Shielding

As shown in Figure 187, Shielding protects the Base Station from the magnetic field that is generated in the Primary Coil. The Shielding should be Ni-Zn or Mn-Zn ferrite and should be at least 2.0 mm thick.

The top face of the Shielding block is aligned with the top face of the Primary Coil, such that the Shielding surrounds the Primary Coil on all sides except for the top face. In addition, the Shielding extends to at least 2.5 mm beyond the outer edge of the Primary Coil.

Table 125. Primary Coil assembly of Power Transmitter design MP-A3

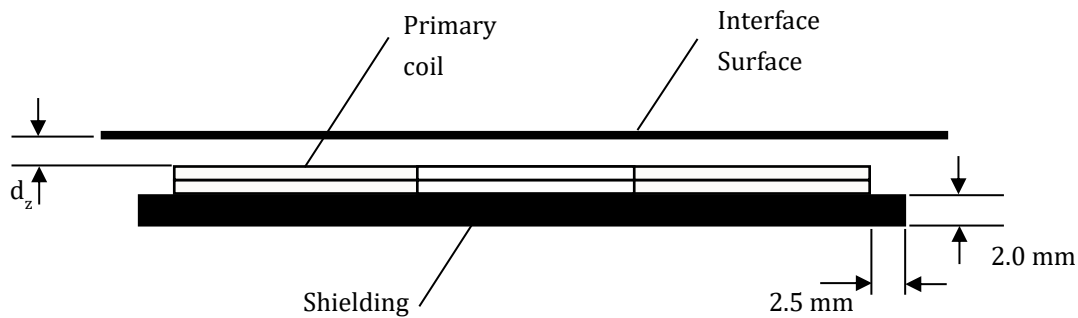

2.4.3.1.3 Interface Surface

As shown in Figure 187, the distance from the Primary Coil to the Interface Surface of the Base Station is $d_z = 3.0^{\pm 0.5}$ mm, across the top face of the Primary Coil. In addition, the Interface Surface of the Base Station extends at least 5 mm beyond the outer diameter of the Primary Coil.

2.4.3.1.4 Inter-coil separation

If the Base Station contains multiple type MP-A3 Power Transmitters, the Primary Coils of any pair of those Power Transmitters shall have a center-to-center distance of at least $55.0^{\pm 0.5}$ mm.

2.4.3.2 Electrical details

As shown in Figure 188, Power Transmitter design MP-A3 uses a full-bridge inverter topology to drive the Primary Coil and a series capacitance. Within the Operating Frequency range specified in this section, the Primary Coil and Shielding assembly has a self-inductance value of $L_p = 10.1^{\pm 5\%}$ μH . The value of the series capacitance is $C_p = 251^{\pm 10\%}$ nF.

NOTE Near resonance, the voltage developed across the series capacitance can reach levels up to 100 V pk-pk.

Power Transmitter design MP-A3 uses the combination of the Operating Frequency, the input voltage, and the duty cycle of the full-bridge inverter to control the amount of power transferred. For this purpose, the input voltage has a range of $2.5^{\pm 0.5}$ V to $11.5^{\pm 0.5}$ V, with a resolution of 10 mV or better. A higher input voltage results in more power transferred. The Operating Frequency is $f_{op} = 110$ kHz to 205 kHz with a duty cycle of 50%, and the duty cycle range is 0 to 50% at an Operating Frequency of 205 kHz.

When a type MP-A3 Power Transmitter first applies a Power Signal (Digital Ping), the Power Transmitter shall use an Operating Frequency in the range of 160 kHz to 180 kHz with an input voltage of $12.0^{\pm 0.25}$ V. If the Power Transmitter does not receive a Signal Strength Packet from the Power Receiver, the Power Transmitter shall remove the Power Signal. The Power Transmitter may reapply the Power Signal multiple times at other, consecutively lower, Operating Frequencies within the range specified above until the Power Transmitter receives a Signal Strength Packet containing an appropriate Signal Strength Value.

Figure 188. Electrical diagram (outline) of Power Transmitter design MP-A3

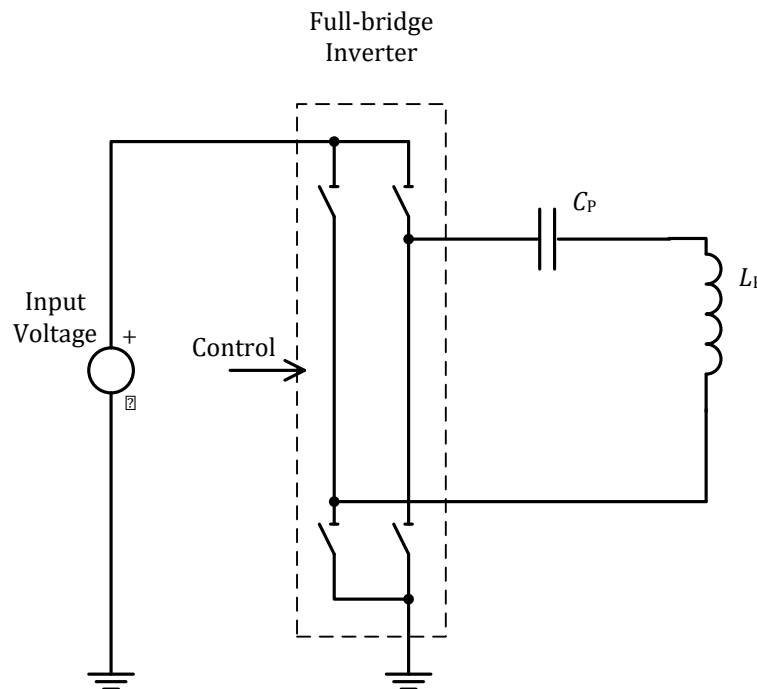

Control of the power transfer shall proceed using the PID algorithm that is defined in *Parts 1 and 2: Interface Definitions*. The controlled variable $v^{(i)}$ introduced in the definition of that algorithm represents the Operating Frequency, the input voltage, or the duty cycle of the full-bridge inverter. It is recommended that control of the power occurs primarily by means of adjustments to the Operating Frequency, and that voltage or duty cycle adjustments are made only at the boundaries of the Operating Frequency range. In order to guarantee sufficiently accurate power control, a type MP-A3 Power Transmitter shall determine the amplitude of the Primary Coil current with a resolution of 7 mA or better.

Table 126, Table 127, and Table 128 provide the values of the parameters that are used in the PID algorithm.

Table 126. PID parameters for Operating Frequency control

Parameter	Symbol	Value	Unit
Proportional gain	K_p	1	mA^{-1}
Integral gain	K_i	0	$\text{mA}^{-1}\text{ms}^{-1}$
Derivative gain	K_d	0	mA^{-1}ms
Integral term limit	M_I	N.A.	N.A.
PID output limit	M_{PID}	20,000	N.A.
Scaling factor	S_v	1.0	Hz

Table 127. PID parameters for voltage control

Parameter	Symbol	Value	Unit
Proportional gain	K_p	1	mA^{-1}
Integral gain	K_i	0	$\text{mA}^{-1}\text{ms}^{-1}$
Derivative gain	K_d	0	mA^{-1}ms
Integral term limit	M_I	N.A.	N.A.
PID output limit	M_{PID}	1,500	N.A.
Scaling factor	S_v	-0.5	mV

Table 128. PID parameters for duty cycle control

Parameter	Symbol	Value	Unit
Proportional gain	K_p	1	mA^{-1}
Integral gain	K_i	0	$\text{mA}^{-1}\text{ms}^{-1}$
Derivative gain	K_d	0	mA^{-1}ms
Integral term limit	M_I	N.A.	N.A.
PID output limit	M_{PID}	20,000	N.A.
Scaling factor	S_v	0.1	%

2.4.3.3 Information interface

The Not Res Sens Bit in the Configuration Packet shall be set to ZERO.

2.4.4 Power Transmitter design MP-A4

Figure 189 illustrates the functional block diagram of Power Transmitter design MP-A4, which consists of two major functional units, namely a Power Conversion Unit and a Communications and Control Unit.

Figure 189. Functional block diagram of Power Transmitter design MP-A4

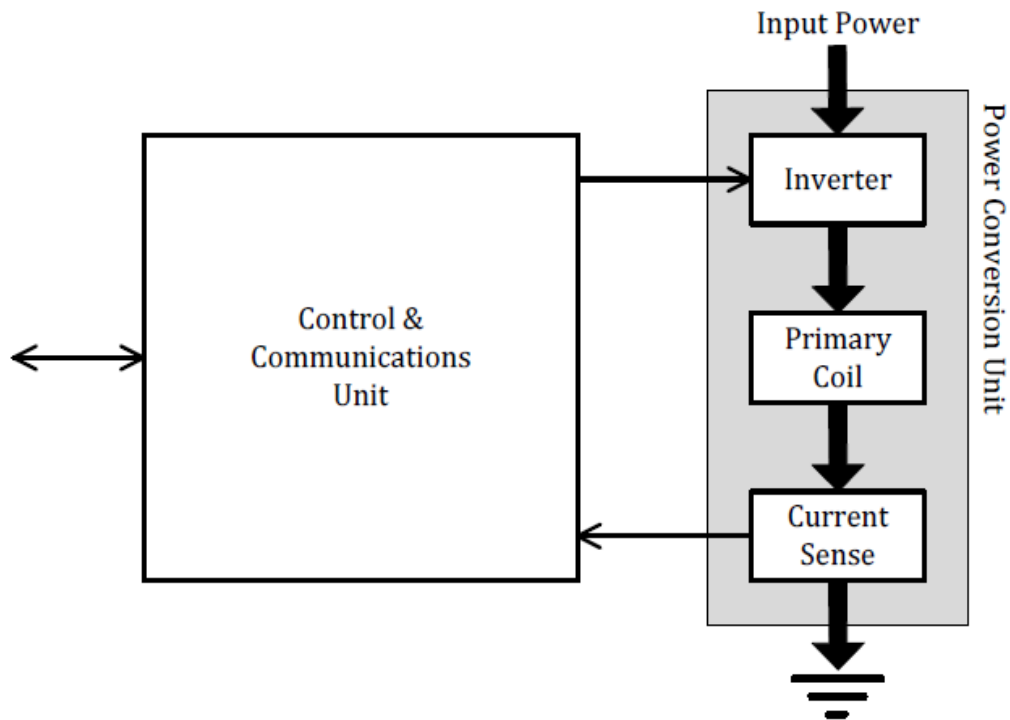

The Power Conversion Unit on the right-hand side of Figure 189 comprises the analog parts of the design. The inverter converts the DC input to an AC waveform that drives a resonant circuit, which consists of the Primary Coil plus a series capacitor. Finally, the current sense monitors the Primary Coil current.

The Communications and Control Unit on the left-hand side of Figure 189 comprises the digital logic part of the design. This unit receives and decodes messages from the Power Receiver, executes the relevant power control algorithms and protocols, and drives the frequency of the AC waveform to control the power transfer. The Communications and Control Unit also interfaces with other subsystems of the Base Station, e.g. for user interface purposes.

2.4.4.1 Mechanical details

This section defines the Primary Coil, the Shielding, the Interface Surface, and the alignment aid for Power Transmitter design MP-A4.

2.4.4.1.1 Primary Coil

The Primary Coil is of the wire-wound type, and consists of litz wire with nylon spinning having 180 strands of no. 42 AWG (0.06 mm diameter), or equivalent. As shown in Figure 190 the Primary Coil has a round shape and consists of a single layer. Table 129 lists the dimensions and other parameters of the Primary Coil.

Figure 190. Primary Coil of Power Transmitter design MP-A4

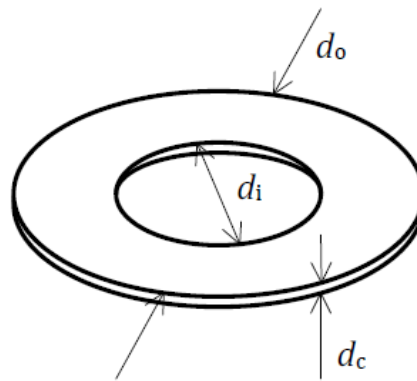

Table 129. Primary Coil parameters of Power Transmitter design MP-A4

Parameter	Symbol	Value
Outer diameter	d_o	$48.5^{\pm 1.0}$ mm
Inner diameter	d_i	$23.0^{\pm 1.0}$ mm
Coil thickness	d_c	$2.0^{\pm 0.5}$ mm
Number of turns per layer	N	11
Number of layers	—	1

2.4.4.1.2 Shielding

As shown in Figure 191, Shielding protects the Base Station from the magnetic field that is generated in the Primary Coil. The Shielding should be Ni-Zn or Mn-Zn ferrite and should be at least 0.5 mm thick. The Shielding extends to at least 2 mm beyond the outer diameter of the Primary Coils, and is placed below the Primary Coil at a distance of at most $d_s = 1.0$ mm.

Figure 191. Primary Coil assembly of Power Transmitter design MP-A4

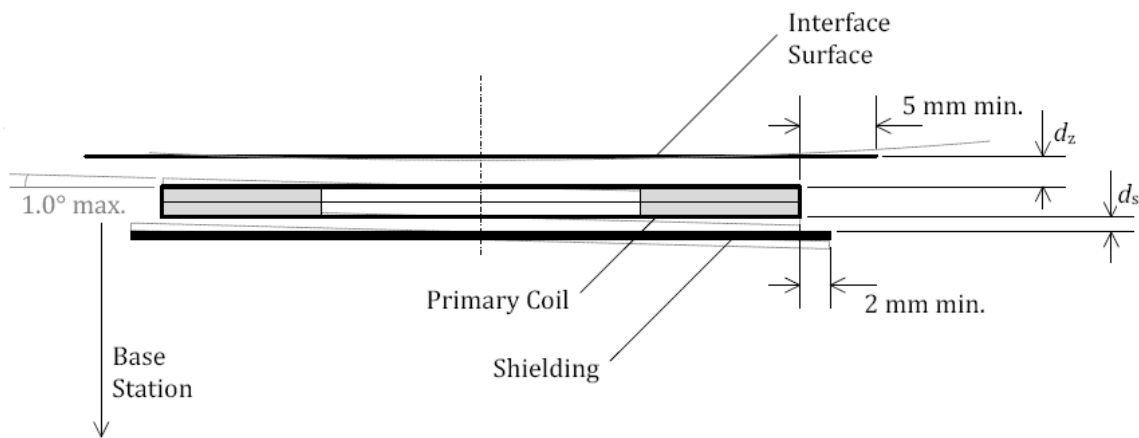

2.4.4.1.3 Interface surface

As shown in Figure 191, the distance from the Primary Coil to the Interface Surface of the Base Station is $d_z = 2^{\pm 1}$ mm, across the top face of the Primary Coil. In addition, the Interface Surface of the Base Station extends at least 5 mm beyond the outer dimensions of the Primary Coils.

2.4.4.1.4 Alignment aid

The user manual of a Base Station containing a type MP-A4 Power Transmitter shall provide information about the location of its Active Area(s).

For the best user experience, it is recommended to employ at least one user feedback mechanism during Mobile Device positioning to help alignment.

NOTE Examples of Base Station alignment aids to assist the user positioning of the Mobile Device include:

- A marked Interface Surface to indicate the location of its Active Area(s)—e.g. a logo or other visual marking, lighting, etc.
- A visual feedback display—e.g. by means of illuminating an LED to indicate proper alignment.
- An audible or tactile feedback mechanism.

2.4.4.1.5 Inter-coil separation

If the Base Station contains multiple type MP-A4 Power Transmitters, the Primary Coils of any pair of those Power Transmitters shall have a center-to-center distance of at least 56 mm.

2.4.4.2 Electrical details

As shown in Figure 192, Power Transmitter design MP-A4 uses a full-bridge inverter to drive the Primary Coil and a series capacitance. Within the Operating Frequency range specified below, the assembly of Primary Coil and Shielding has a self-inductance $L_p = 8.9^{\pm 10\%} \mu H$. The value of the series capacitance is $C_p = 276^{\pm 5\%} nF$.

NOTE Near resonance, the voltage developed across the series capacitance can reach levels exceeding 200 V pk-pk.

Power Transmitter design MP-A4 uses the Operating Frequency and the phase difference of the full-bridge inverter's driving signals (see Figure 193), or uses the Operating Frequency and duty cycle of the half-bridge inverter's driving signals (see Figure 194) in order to control the amount of power that is transferred. For this purpose, the Operating Frequency range of the inverter is $f_{op} = 110$ kHz to 205 kHz with a driving signal phase difference of $\alpha = 0^\circ$ to 133° or a duty cycle of $D = 10\%$ to 50% . A higher Operating Frequency, higher phase difference, or lower duty cycle will result in the transfer of a lower amount of power. In order to achieve a sufficiently accurate adjustment of the amount of power that is transferred, a type MP-A4 Power Transmitter shall control the Operating Frequency with a minimum resolution of:

- $0.01 \cdot f_{op} - 0.7$ kHz for f_{op} in the 110 kHz to 175 kHz range;
- $0.015 \cdot f_{op} - 1.58$ kHz for f_{op} in the 175 kHz to 205 kHz range.

In addition, a type MP-A4 Power Transmitter shall control the driving-signal phase difference with a resolution of 0.18° or better. Moreover, a type MP-A4 Power Transmitter shall control the driving-signal duty cycle with a resolution of 0.1% or better.

When a type MP-A4 Power Transmitter first applies a Power Signal (Digital Ping), it shall use an initial input voltage to the half-bridge inverter of $12^{\pm 5\%}$ V and an initial Operating Frequency of 175 kHz and a duty cycle of 50% .

Control of the power transfer shall proceed using the PID algorithm, which is defined in *Parts 1 and 2: Interface Definitions*. The controlled variable ⁽ⁱ⁾ introduced in the definition of that algorithm represents the Operating Frequency, operating duty cycle, or operating phase difference depending on the required power of the Power Receiver. In order to guarantee sufficiently accurate power control, a type MP-A4 Power Transmitter shall determine the amplitude of the Primary Cell current—which is equal to the Primary Coil current—with a resolution of 7 mA or better. Finally, Table 130, Table 131, Table 132, Table 133, and Table 134 provide the values of several parameters that are used in the PID algorithm.

The type MP-A4 Power Transmitter shall handle the different control methodologies as follows.

- At an Operating Frequency of 205 kHz, the Power Transmitter shall operate in half-bridge mode, using duty cycle control with a range of 10% to 50%.
- At Operating Frequencies between 172 kHz and 205 kHz, the Power Transmitter shall operate in half-bridge mode at 50% duty cycle, using frequency control.
- At an Operating Frequency of 172 kHz, the Power Transmitter shall operate in full-bridge mode with a phase difference of 0° to 133° .
- At Operating Frequencies below 172 kHz, the Power Transmitter shall operate in full-bridge mode with a phase difference of 0° using frequency control.

When the Power Transmitter reaches the 172 kHz transition point, it shall

- switch from half-bridge mode to full-bridge mode at a 133° phase difference if moving down in Operating Frequency, or
- switch from full-bridge mode at a 133° phase difference to half-bridge mode if moving up in Operating Frequency.

If the Power Transmitter reaches the 172 kHz transition point in the middle of a PID control loop, the Power Transmitter shall terminate the control loop and wait for subsequent Control Error Packets.

Figure 192. Electrical diagram (outline) of Power Transmitter design MP-A4

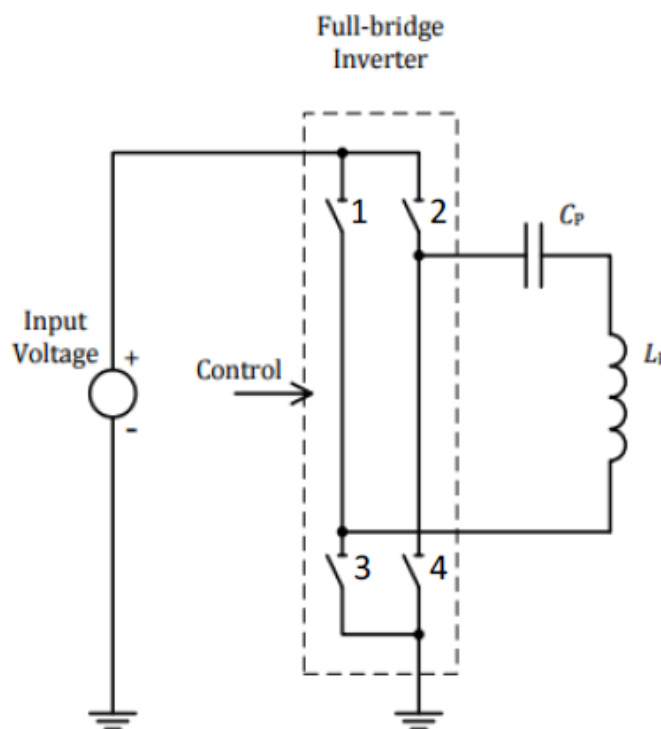

Figure 193. Phase control signals to Full Bridge inverter

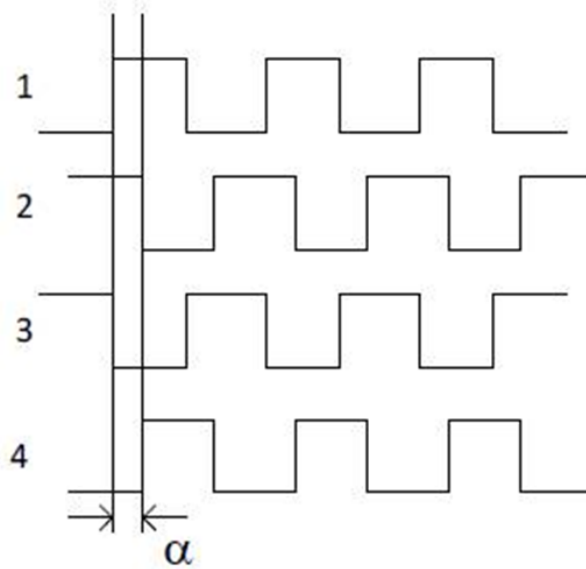

Figure 194. Duty control signals to Half Bridge inverter

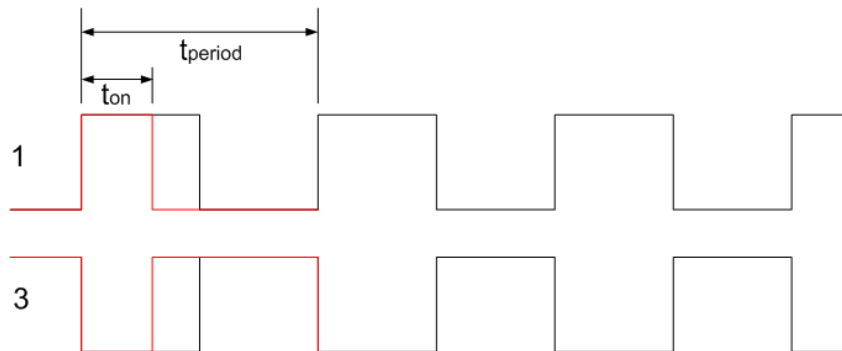

Table 130. PID parameters for Operating Frequency control (half bridge)

Parameter	Symbol	Value	Unit
Proportional gain	K_p	10	mA^{-1}
Integral gain	K_i	1	$\text{mA}^{-1}\text{ms}^{-1}$
Derivative gain	K_d	1	mA^{-1}ms
Integral term limit	M_I	3,000	N.A.
PID output limit	M_{PID}	20,000	N.A.

Table 131. PID parameters for Operating Frequency control (full bridge)

Parameter	Symbol	Value	Unit
Proportional gain	K_p	5	mA^{-1}
Integral gain	K_i	1	$\text{mA}^{-1}\text{ms}^{-1}$
Derivative gain	K_d	1	mA^{-1}ms
Integral term limit	M_i	3,000	N.A.
PID output limit	M_{PID}	20,000	N.A.

Table 132. Operating Frequency dependent scaling factor

Frequency Range[kHz]	Scaling Factor S_v [Hz]
110...140	1.5
140...160	2
160...180	3
180...205	5

Table 133. PID parameters for phase control

Parameter	Symbol	Value	Unit
Proportional gain	K_p	1	mA^{-1}
Integral gain	K_i	1	$\text{mA}^{-1}\text{ms}^{-1}$
Derivative gain	K_d	0	mA^{-1}ms
Integral term limit	M_i	3,000	N.A.
PID output limit	M_{PID}	20,000	N.A.
Scaling factor	S_v	0.009	$^\circ$

Table 134. PID parameters for duty cycle control

Parameter	Symbol	Value	Unit
Proportional gain	K_p	10	mA^{-1}
Integral gain	K_i	1	$\text{mA}^{-1}\text{ms}^{-1}$
Derivative gain	K_d	0	mA^{-1}ms
Integral term limit	M_i	3,000	N.A.
PID output limit	M_{PID}	20,000	N.A.
Scaling factor	S_v	-0.01	%

2.4.4.3 Information interface

The Not Res Sens Bit in the Configuration Packet shall be set to ZERO.

2.4.5 Power Transmitter design MP-A5

Figure 195 illustrates the functional block diagram of Power Transmitter Design MP-A5.

Figure 195. Functional block diagram of Power Transmitter MP-A5

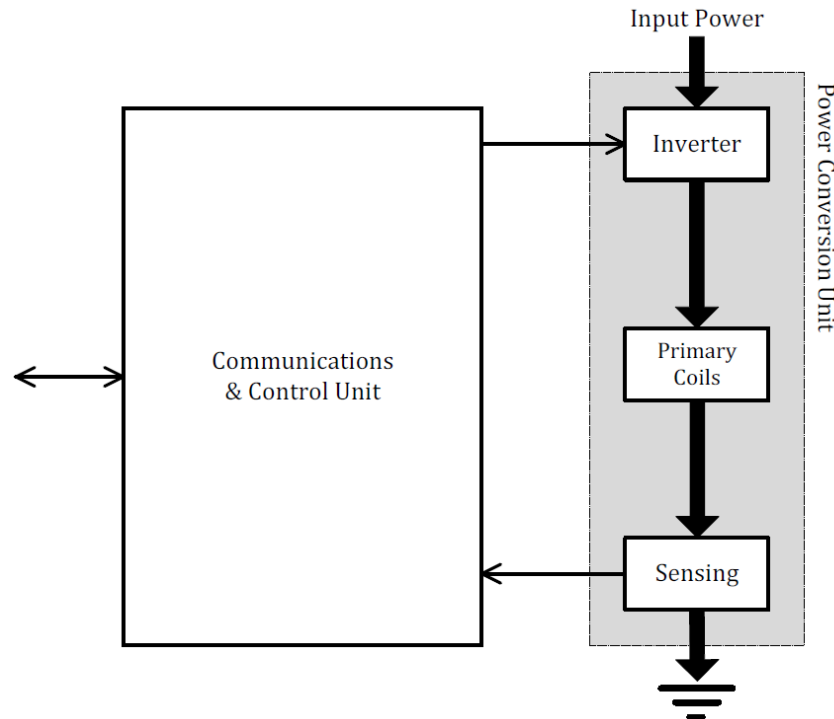

The Power Conversion Unit on the right-hand side of Figure 195 comprises the analog parts of the design. The inverter converts the DC input to an AC waveform that drives a resonant circuit, which consists of the Primary Coil plus a series capacitor. Finally, the voltage and current sense monitors the Primary Coil voltage and current.

The Communications and Control Unit on the left-hand side of Figure 195 comprises the digital logic part of the design. The unit receives and decodes messages from the Power Receiver, executes the relevant power control algorithms and protocols, and drives the input power and frequency of the AC waveform to control the power transfer. The Communications and Control Unit also interfaces with other subsystems of the Base Station, e.g. for user interface purposes.

2.4.5.1 Mechanical details

Power Transmitter design MP-A5 includes a Primary Coil array as defined in Section 2.4.5.1.1, Shielding as defined in Section 2.4.5.1.2, and an Interface Surface as defined in Section 2.4.5.1.3.

2.4.5.1.1 Primary Coil

The Primary Coil is of the wire-wound type, and consists of litz wire with nylon spinning having 180 strands of no. 40 AWG (0.08 mm diameter), or equivalent. As shown in Figure 196 the Primary Coil has a circular shape and consists of two layers with a total of 13 turns. Table 135 lists the dimensions of the Primary Coil.

Figure 196. Primary Coil of Power Transmitter MP-A5

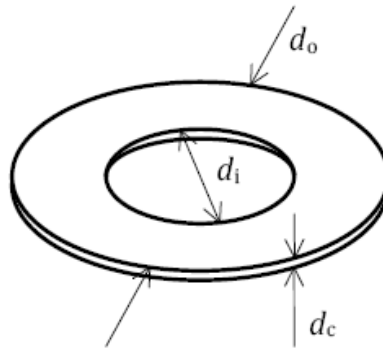

Table 135. Primary Coil of Power Transmitter MP-A5

Parameter	Symbol	Value
Outer diameter	d_o	$41^{\pm 2}$ mm
Inner diameter	d_i	$21^{\pm 0.5}$ mm
Thickness	d_c	$3^{\pm 0.5}$ mm
Numbers of turns per layer	N	6.5
Number of layers	-	2

2.4.5.1.2 Shielding

As shown in Figure 197, Shielding protects the Base Station from the magnetic field that is generated in the Primary Coil. The Shielding should be Ni-Zn or Mn-Zn ferrite and should be at least 2.5 mm thick. The Shielding extends to at least 3.5 mm beyond the outer diameter of the Primary Coil, and is placed below the Primary Coil at a distance of at most $d_s = 1.0$ mm.

Figure 197. Primary Coil assembly of Power Transmitter design MP-A5

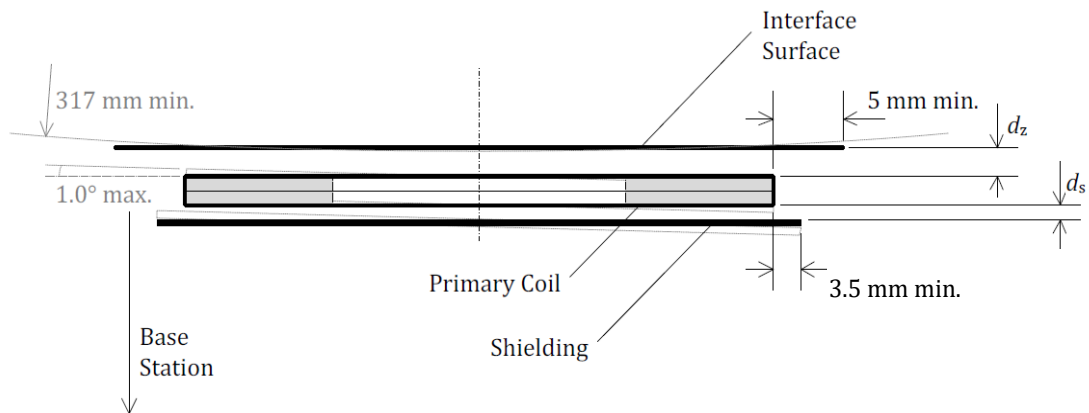

2.4.5.1.3 Interface Surface

As shown in Figure 197, the distance from the Primary Coil to the Interface Surface of the Base Station is $d_z = 2.5^{±0.5}$ mm, across the top face of the Primary Coil. In addition, the Interface Surface of the Base Station extends at least 5 mm beyond the outer diameter of the Primary Coil.

NOTE This Primary- Coil-to-Interface-Surface distance implies that the tilt angle between the Primary Coil and a flat Interface Surface is at most 1.0° . Alternatively, in case of a non-flat Interface Surface, this Primary-Coil-to-Interface-Surface distance implies a radius of curvature of the Interface Surface of at least 317 mm, centered on the Primary Coil. See Figure 197.

2.4.5.1.4 Alignment Aid

The user manual of the Base Station containing a type MP-A5 Power Transmitter shall have information about the location of its Active Area(s).

For the best user experience, it is recommended to employ at least one user feedback mechanism during Mobile Device positioning to help alignment.

NOTE Examples of Base Station alignment aids to assist the user positioning of the Mobile Device include:

- A marked Interface Surface to indicate the location of the Active Area(s)—e.g. by means of the logo or other visual marking, lighting, etc.
- A visual feedback display—e.g. by means of illuminating an LED to indicate proper alignment.
- An audible or haptic feedback mechanism.

2.4.5.1.5 Inter coil separation

If the Base Station contains multiple type MP-A5 Power Transmitters, the Primary Coils of any pair of those Power Transmitters shall have a center-to-center distance of at least 70 mm.

2.4.5.2 Electrical Details

As shown in Figure 198, Power Transmitter design MP-A5 uses a full-bridge inverter to drive the resonant network with a primary Coil with a series capacitance. Within the Operating Frequency range specified below, the assembly of Primary Coil and Shielding, has a self inductance $L_p = 10^{\pm 10\%}$ μ H. The value of the total series capacitance $C_p = 247^{\pm 5\%}$ nF, where the individual series capacitances may have any value less than the sum.

NOTE Near resonance, the voltage developed across the series capacitance can reach levels exceeding 100 V pk-pk.

Power Transmitter design MP-A5 uses the input voltage to the inverter to control the amount of power transferred. For this purpose, the input voltage has a range $1^{\pm 5\%} \dots 12^{\pm 5\%}$ V, with a resolution of 40 mV or better; a higher input voltage results in more power transferred. The Operating Frequency is $130^{\pm 3\%}$ kHz with a duty cycle of 50%.

When a type MP-A5 Power Transmitter first applies a Power Signal (Digital Ping; see *Parts 1 and 2: Interface Definitions*), it shall use an Operating Frequency of 130 kHz and a recommended input voltage of 4 V.

Control of the power transfer shall proceed using the PID algorithm, which is defined in *Parts 1 and 2: Interface Definitions*. The controlled variable $v^{(i)}$ introduced in the definition of that algorithm represents the input voltage. Finally, Table 136 provides the values of several parameters that are used in the PID algorithm.

Figure 198. Electrical diagram (outline) Primary Coil of Power Transmitter design MP-A5

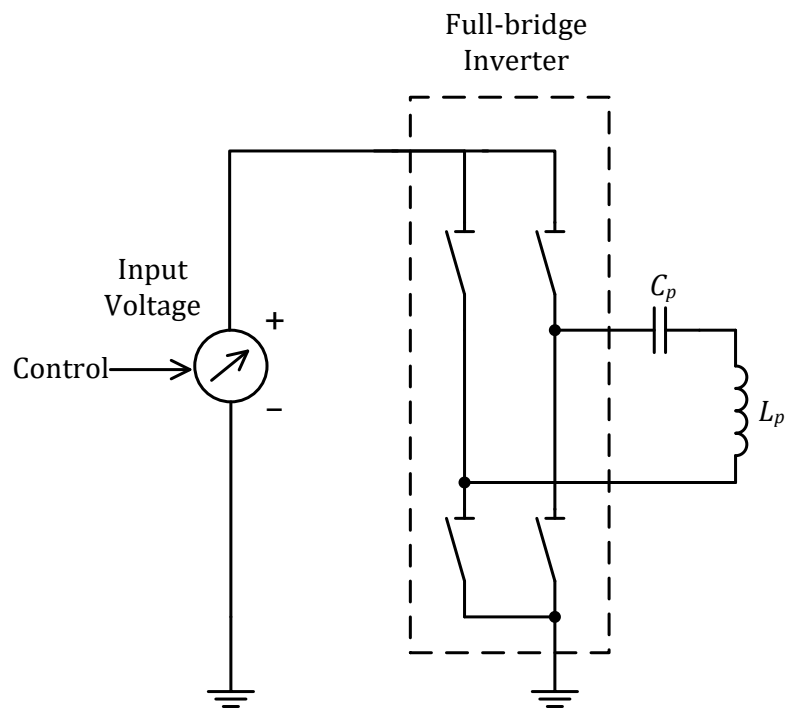

Table 136. PID parameters for voltage control

Parameter	Symbol	Value	Unit
Proportional Gain	K_p	10	mA^{-1}
Integral Gain	K_i	0.05	$\text{mA}^{-1}\text{ms}^{-1}$
Derivative Gain	K_d	0	$\text{mA}^{-1}\text{ms}^{-1}$
Integral Term Limit	M_I	3,000	N.A.
PID output limit	M_{PID}	20,000	N.A.
Scaling factor	S_v	-0.01	%

2.4.5.3 Information interface

The Not Res Sens Bit in the Configuration Packet shall be set to ONE.

2.4.6 Power Transmitter design MP-A6

Figure 199 illustrates the functional block diagram of Power Transmitter design MP-A6. This design consists of two major functional units, namely a Power Conversion Unit and a Communications and Control Unit.

Figure 199. Functional block diagram of Power Transmitter design MP-A6

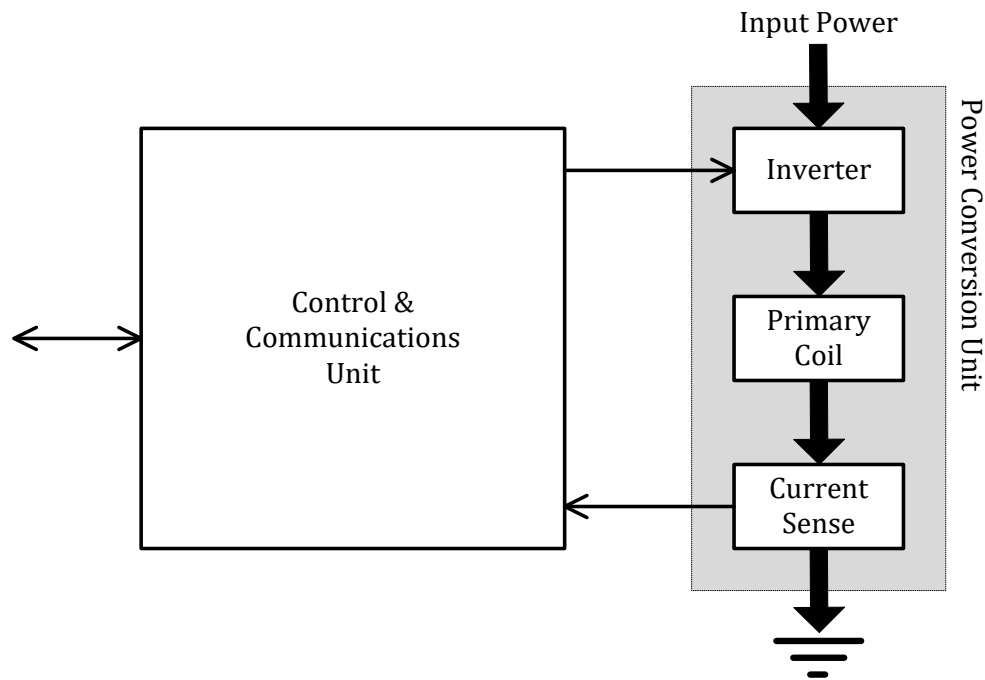

The Power Conversion Unit on the right-hand side of Figure 199 comprises the analog parts of the design. The inverter converts the DC input to an AC waveform that drives a resonant circuit, which consists of the Primary Coil plus a series capacitor. Finally, the current sense monitors the Primary Coil current.

The Communications and Control Unit on the left-hand side of Figure 199 comprises the digital logic part of the design. This unit receives and decodes messages from the Power Receiver, executes the relevant power control algorithms and protocols, and drives the frequency of the AC waveform to control the power transfer. The Communications and Control Unit also interfaces with other subsystems of the Base Station, e.g. for user interface purposes.

2.4.6.1 Mechanical details

This section defines the Primary Coils, the Shielding, and the Interface Surface for Power Transmitter design MP-A6.

2.4.6.1.1 Primary Coil

The Primary Coil is of the wire-wound type, and consists of no. 17 AWG litz wire having 105 strands of no. 40 AWG (0.08 mm diameter), or equivalent. As shown in Figure 200, the Primary Coils have two types of rectangular shape and each coil consists of a single layer. Table 137 and Table 138 list the dimensions of both bottom (close to ferrite) and top (close to interface) Primary Coil.

Figure 200. Bottom and Top Primary Coils of Power Transmitter design MP-A6

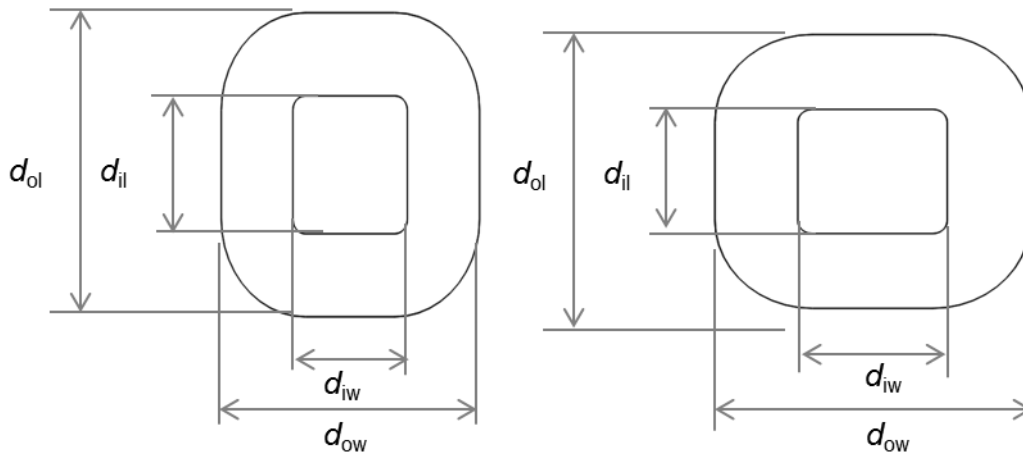

Table 137. Bottom Primary Coil parameters of Power Transmitter design MP-A6

Parameter	Symbol	Value
Outer height	d_{ol}	$49.0^{\pm 1.0}$ mm
Inner height	d_{il}	$26.0^{\pm 1.0}$ mm
Outer width	d_{ow}	$44.0^{\pm 1.0}$ mm
Inner width	d_{iw}	$22.0^{\pm 1.0}$ mm
Thickness	d_c	$1.1^{\pm 0.2}$ mm
Number of turns per layer	N	11
Number of layers	—	1

Table 138. Top Primary Coil parameters of Power Transmitter design MP-A6

Parameter	Symbol	Value
Outer height	d_{ol}	46.0 \pm 1.0 mm
Inner height	d_{il}	21.0 \pm 1.0 mm
Outer width	d_{ow}	49.5 \pm 1.0 mm
Inner width	d_{iw}	25.5 \pm 1.0 mm
Thickness	d_c	1.1 \pm 0.2 mm
Number of turns per layer	N	12
Number of layers	—	1

Power Transmitter design MP-A6 contains three Primary Coils. Bottom Primary Coil #1 and bottom Primary Coil #2 are placed alongside each other with a displacement of $d_{12} = 46\pm 4$ mm between their centers. The top Primary Coil is placed orthogonal to the bottom Primary Coils, with a displacement of $d_{bt} = 23\pm 2$ mm between their centers. See Figure 201.

Figure 201. Bottom and Top Primary Coils of Power Transmitter design MP-A6

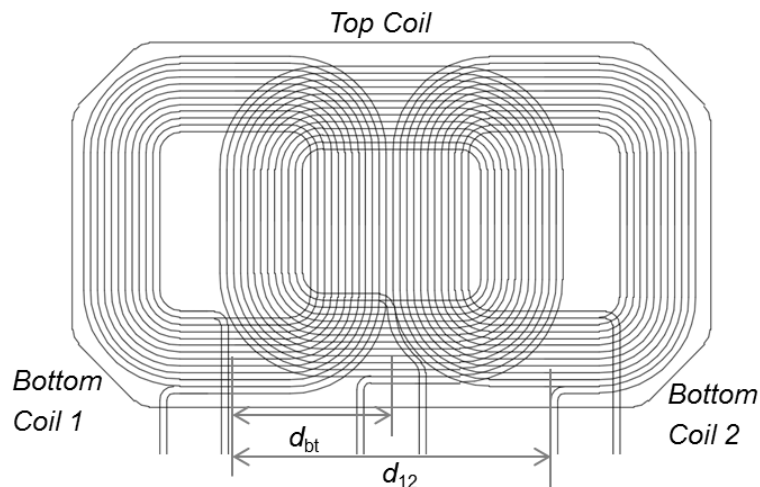

2.4.6.1.2 Shielding

As shown in Figure 202, a soft-magnetic material protects the Base Station from the magnetic field that is generated in the Primary Coils. The Shielding extends to at least 2 mm beyond the outer dimensions of the Primary Coils, has a thickness of at least 1.5 mm, and is placed below the Primary Coils at a distance of at most $d_s = 1.0$ mm. This version of *Part 4: Reference Designs* limits the composition of the Shielding to any Mn-Zn (for example, PM12 from TODAISU).

Figure 202. Primary Coil assembly of Power Transmitter design MP-A6

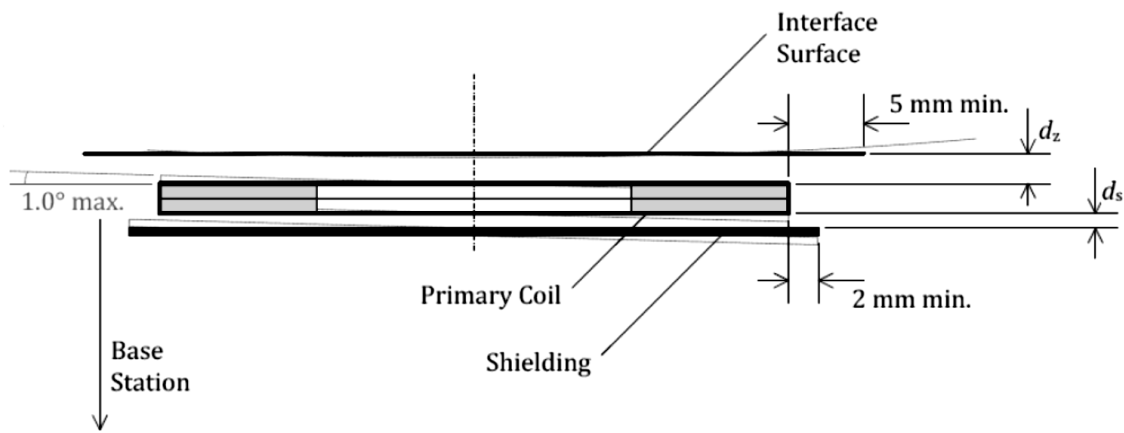

2.4.6.1.3 Interface Surface

As shown in Figure 202, the distance from the Primary Coil to the Interface Surface of the Base Station is $d_z = 5.5^{±1.5}$ mm across the top face of the Primary Coil. In addition, the Interface Surface of the Base Station extends at least 5 mm beyond the outer dimensions of the Primary Coils.

2.4.6.1.4 Alignment aid

The user manual of the Base Station containing type MP-A6 Power Transmitter shall provide information about the location of its Active Area(s).

For the best user experience, it is recommended to employ at least one user feedback mechanism during Mobile Device placement to help alignment.

NOTE Examples of Base Station alignment aids to assist the user placement of the Mobile Device include:

- A marked Interface Surface to indicate the location of its Active Area(s)—e.g. a logo or other visual marking, lighting, etc.
- A visual feedback display—e.g. by means of illuminating an LED to indicate proper alignment.
- An audible or haptic feedback mechanism.

2.4.6.1.5 Inter coil separation

If the Base Station contains multiple type MP-A6 Power Transmitters, the Primary Coils of any pair of those Power Transmitters shall have a center-to-center distance of at least $49.2^{±4}$ mm.

2.4.6.2 Electrical details

As shown in Figure 203, Power Transmitter design MP-A6 uses a full-bridge inverter to drive an individual Primary Coil and a series capacitance. Within the Operating Frequency range specified below, the assembly of Primary Coils and Shielding has a self inductance $L_p = 11.3^{\pm 0.7} \mu\text{H}$. The value of the series capacitance is $C_p = 139^{\pm 6\%} \text{nF}$.

NOTE Near resonance, the voltage developed across the series capacitance can reach levels exceeding 200 V pk-pk.

Power Transmitter design MP-A6 uses the input voltage of the inverter to control the amount of power that is transferred. For this purpose, the input voltage has a range of 1 to 18 V with a resolution of 10 mV or better. The Operating Frequency is $f_{op} = 140$ to 150 kHz with a duty cycle of 50%.

When Power Transmitter design MP-A6 first applies a Power Signal (see Digital Ping in *Parts 1 and 2: Interface Definitions*), it shall use an initial voltage of $5.0^{\pm 0.5} \text{V}$ for a bottom and top Primary Coils, and a recommended Operating Frequency of 145 kHz.

Control of the power transfer shall proceed using the PID algorithm, which is defined in *Parts 1 and 2: Interface Definitions*. The controlled variable $v^{(i)}$ introduced in the definition of that algorithm represents the input voltage to the inverter. In order to guarantee sufficiently accurate power control, Power Transmitter design MP-A6 shall determine the amplitude of the Primary Cell current—which is equal to the Primary Coil current—with a resolution of 7 mA or better. Finally, Table 139 provides the values of several parameters, which are used in the PID algorithm.

Figure 203. Electrical diagram (outline) of Power Transmitter design MP-A6

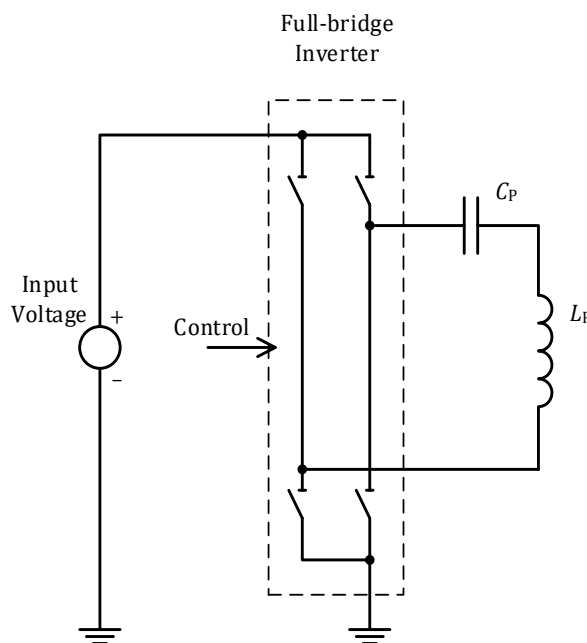

Table 139. PID parameters for Voltage control

Parameter	Symbol	Value	Unit
Proportional gain	K_p	10	mA^{-1}
Integral gain	K_i	1	$\text{mA}^{-1}\text{ms}^{-1}$
Derivative gain	K_d	0	mA^{-1}ms
Integral term limit	M_I	3,000	N.A.
PID output limit	M_{PID}	20,000	N.A.
Scaling factor	S_V	100	mV

2.4.6.3 Information interface

The Not Res Sens Bit in the Configuration Packet shall be set to ONE.

2.4.7 Power Transmitter design MP-A7

Figure 204 illustrates the functional block diagram of Power Transmitter design MP-A7. This design consists of two major functional units, namely a Power Conversion Unit and a Communications and Control Unit.

Figure 204. Functional block diagram of Power Transmitter design MP-A7

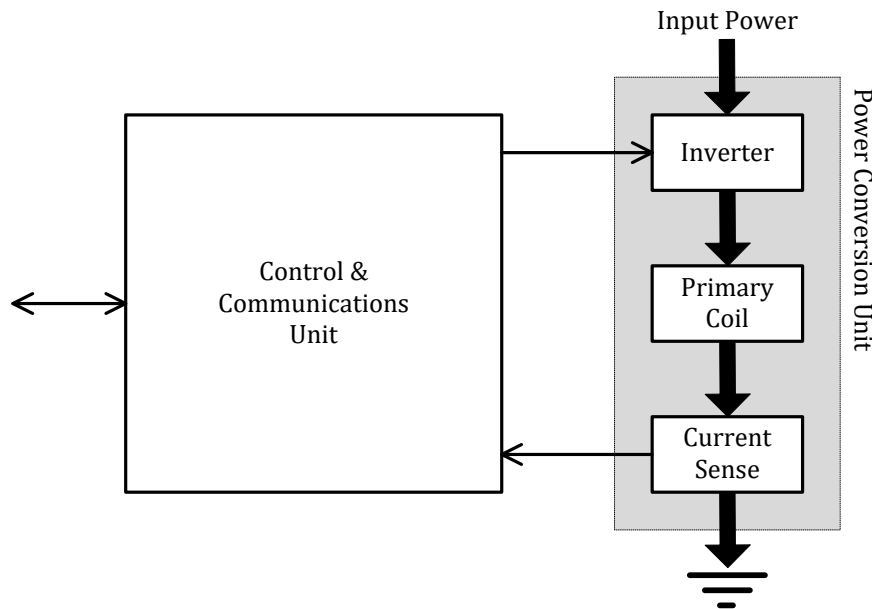

The Power Conversion Unit on the right-hand side of Figure 204 comprises the analog parts of the design. The inverter converts the DC input to an AC waveform that drives a resonant circuit consisting of the Primary Coil plus a series capacitor. Finally, the current sense monitors the Primary Coil current.

The Communications and Control Unit on the left-hand side of Figure 204 comprises the digital logic part of the design. This unit receives and decodes messages from the Power Receiver, executes the relevant power control algorithms and protocols, and drives the frequency of the AC waveform to control the power transfer. The Communications and Control Unit also interfaces with other subsystems of the Base Station, e.g. for user interface purposes.

2.4.7.1 Mechanical details

This section defines the Primary Coil, the Shielding, the Interface Surface, and the alignment aid for Power Transmitter design MP-A7.

2.4.7.1.1 Primary Coil

The Primary Coil of the MP-A7 design is identical to the Primary Coil of the type A10 Power Transmitter.

2.4.7.1.2 Shielding

As shown in Figure 205, Shielding protects the Base Station from the magnetic field that is generated in the Primary Coil. The Shielding should be Ni-Zn or Mn-Zn ferrite and should be at least 2.0 mm thick. The Shielding extends to at least 2 mm beyond the outer diameter of the Primary Coil, and is placed below the Primary Coil at a distance of at most $d_s = 1.0$ mm.

Figure 205. Primary Coil assembly of Power Transmitter design MP-A7

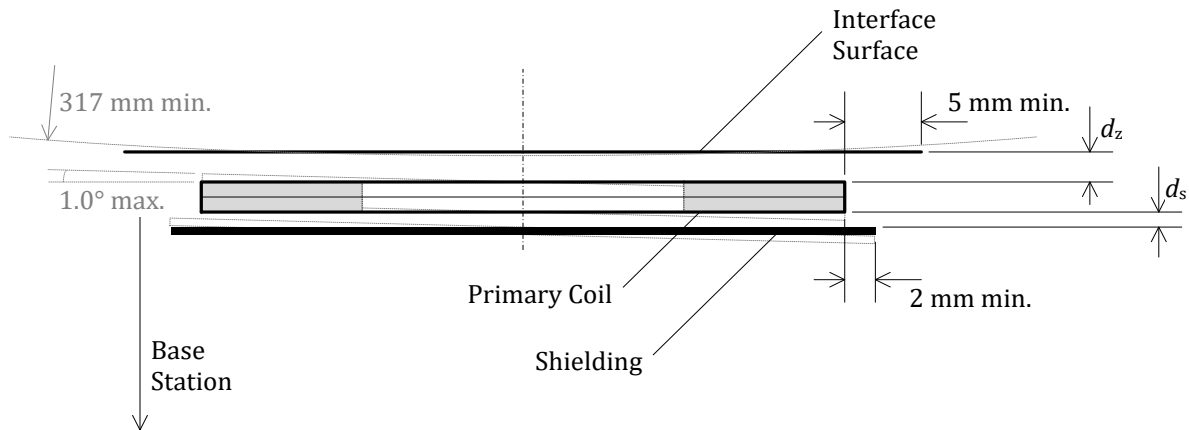

2.4.7.1.3 Interface Surface

As shown in Figure 205, the distance from the Primary Coil to the Interface Surface of the Base Station is $d_z = 2^{+0.5}_{-0.25}$ mm, across the top face of the Primary Coil. In addition, the Interface Surface of the Base Station extends at least 5 mm beyond the outer diameter of the Primary Coil.

NOTE This Primary-Coil-to-Interface-Surface distance implies that the tilt angle between the Primary Coil and a flat Interface Surface is at most 1.0°. Alternatively, in case of a non-flat Interface Surface, this Primary-Coil-to-Interface-Surface distance implies a radius of curvature of the Interface Surface of at least 317 mm, centered on the Primary Coil. See Figure 205.

2.4.7.1.4 Alignment aid

The user manual of a Base Station containing a type MP-A7 Power Transmitter shall provide information about the location of its Active Area(s).

For the best user experience, it is recommended to employ at least one user feedback mechanism during Mobile Device positioning to help alignment.

NOTE Examples of Base Station alignment aids to assist the user positioning of the Mobile Device include:

- A marked Interface Surface to indicate the location of the Active Area(s)—e.g. a logo or other visual marking, lighting, etc.
- A visual feedback display—e.g. by means of illuminating an LED to indicate proper alignment.
- An audible or tactile feedback mechanism.

2.4.7.1.5 Inter-coil separation

If the Base Station contains multiple type A7 Power Transmitters, the Primary Coils of any pair of those Power Transmitters shall have a center-to-center distance of at least 50 mm.

2.4.7.2 Electrical details

As shown in Figure 208, Power Transmitter design MP-A7 uses a full-bridge inverter to drive the Primary Coil and a series capacitance. Within the Operating Frequency range specified below, the assembly of Primary Coil and Shielding has a self-inductance $L_p = 24^{\pm 10\%}$ μH . The value of the series capacitance is $C_p = 100^{\pm 5\%}$ nF.

NOTE Near resonance, the voltage developed across the series capacitance can reach levels exceeding 200 V pk-pk.

Power Transmitter design MP-A7 uses the Operating Frequency and the phase difference of the full-bridge inverter's driving signals (see Figure 209), or uses the Operating Frequency and duty cycle of the half-bridge inverter's driving signals (see Figure 210) in order to control the amount of power that is transferred. For this purpose, the Operating Frequency range of the inverter is $f_{op} = 110$ kHz to 205 kHz with a driving signal phase difference of $\alpha = 0^\circ$ to 90° or a duty cycle of $t_{on}/t_{period} = 10\%$ to 50% . A higher Operating Frequency, higher phase, or lower duty cycle will result in the transfer of a lower amount of power.

In order to achieve a sufficiently accurate adjustment of the amount of power that is transferred, a type MP-A7 Power Transmitter shall control the Operating Frequency with a minimum resolution of:

- $0.01 \cdot f_{op} - 0.7$ kHz for f_{op} in the 110 kHz to 175 kHz range;
- $0.015 \cdot f_{op} - 1.58$ kHz for f_{op} in the 175 kHz to 205 kHz range;

In addition, a type MP-A7 Power Transmitter shall control the driving-signal phase difference with a resolution of 0.18° or better. Moreover, a type MP-A7 Power Transmitter shall control the driving-signal duty cycle with a resolution of 0.1% or better.

When a type MP-A7 Power Transmitter first applies a Power Signal (Digital Ping), it shall use an initial input voltage to the half-bridge inverter of $19^{\pm 1}$ V and an initial Operating Frequency range of 170 kHz to 180 kHz and a duty cycle of 50%.

Control of the power transfer shall proceed using the PID algorithm, which is defined in *Parts 1 and 2: Interface Definitions*. The controlled variable $v^{(i)}$ introduced in the definition of that algorithm represents the Operating Frequency, operating duty cycle, or operating phase difference depending on the required power of the Power Receiver. In order to guarantee sufficiently accurate power control, a type MP-A7 Power Transmitter shall determine the amplitude of the Primary Cell current—which is equal to the Primary Coil current—with a resolution of 7 mA or better. Finally, Table 142, Table 143, Table 144, and Table 145 provide the values of several parameters that are used in the PID algorithm.

The type MP-A7 Power Transmitter shall operate as follows to control the power transfer.

1. If the Power Transmitter serves a Power Receiver in the Baseline Power Profile, the Power Transmitter shall operate only in half-bridge mode. Additional operating requirements:
 - At an Operating Frequency of 205 kHz, the Power Transmitter shall operate using duty cycle control in the range of 10% to 50%.
 - At Operating Frequencies below 205 kHz, the Power Transmitter shall operate at 50% duty cycle using frequency control.
2. If the Power Transmitter serves a Power Receiver in the Extended Power Profile, the Power Transmitter operates in either half-bridge or full-bridge mode depending on the control parameters in use. This is illustrated in Figure 206 and Figure 207 and their corresponding tables of control parameter requirements. Note that the dashed line in these figures indicates the crossover point between the two operating modes (full bridge and half bridge) where both control variables change simultaneously.

Figure 206. Increasing power

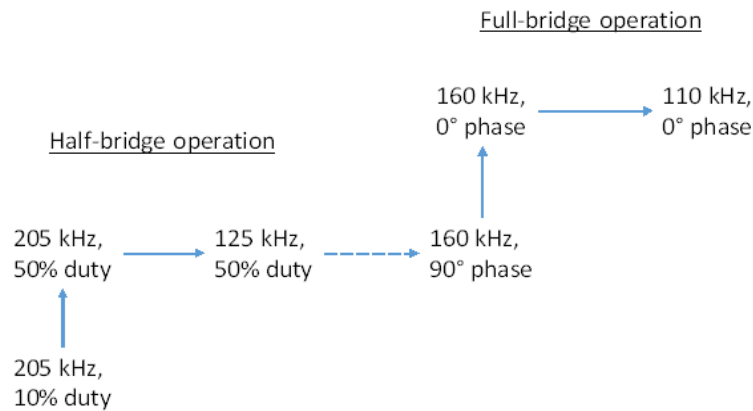

Table 140. Control parameter requirements for increasing power

Control parameters	Mode	Description
10% to 50% duty cycle at 205 kHz	Half bridge	Low-power range in half-bridge operation.
205 kHz to 125 kHz at 50% duty cycle	Half bridge	High-power range in half-bridge operation.
125 kHz, 50% duty cycle to 160 kHz, 90° phase	Half bridge to Full bridge	Crossover from half-bridge to full-bridge operation; the power may go up or down depending on the PRx design, load, and coupling.
90° to 0° phase at 160 kHz	Full bridge	Low-power range in full-bridge operation.
160 kHz to 110 kHz at 0° phase	Full bridge	High-power range in full-bridge operation.

Figure 207. Decreasing power

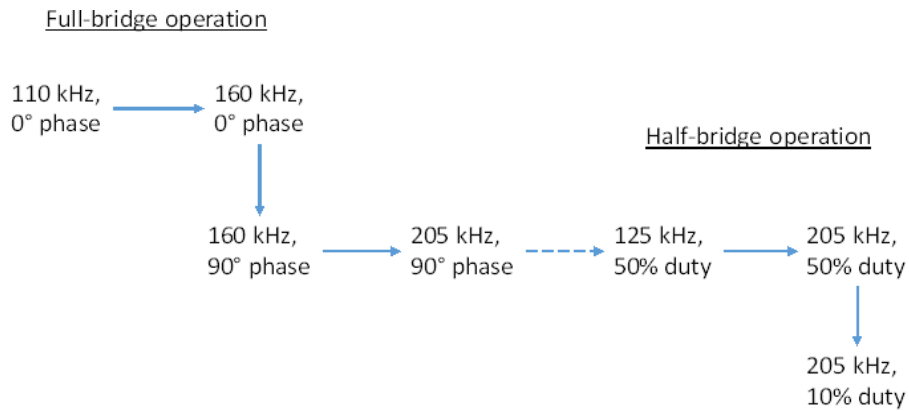

Table 141. Control parameter requirements for decreasing power

Control parameters	Mode	Description
110 kHz to 160 kHz at 0° phase	Full bridge	High-power range in full-bridge operation.
0° to 90° phase at 160 kHz	Full bridge	Medium-power range in full-bridge operation.
160 kHz to 205 kHz at 90° phase	Full bridge	Low-power range in full-bridge operation.
205 kHz at 90° phase to 125 kHz, 50% duty cycle	Full bridge to Half bridge	Crossover from FB to HB operation; the power may go up or down depending on the PRx design, load and coupling.
125 kHz to 205 kHz at 50% duty cycle	Half bridge	High-power range in half-bridge operation.
50% to 10% duty cycle at 205 kHz	Half bridge	Low-power range in half-bridge operation.

If the Power Transmitter reaches the crossover point (half bridge ↔ full bridge) in the middle of a PID control loop, the Power Transmitter shall terminate the control loop and wait for subsequent Control Error Packets.

Figure 208. Electrical diagram (outline) of Power Transmitter design MP-A7

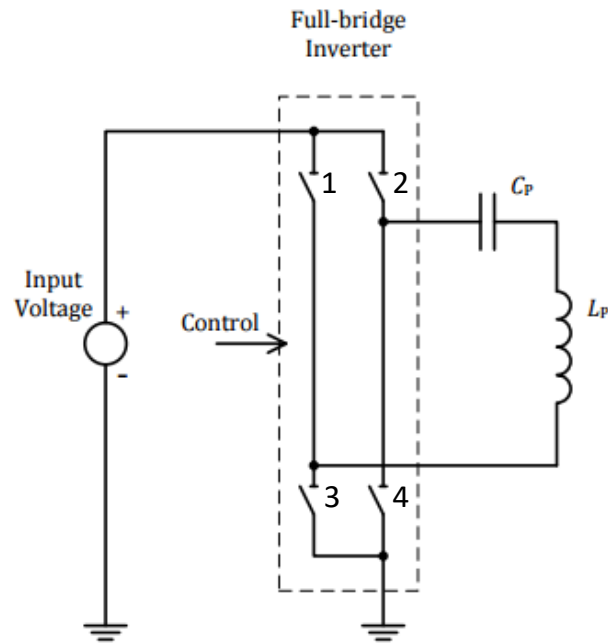

Table 142. PID parameters for Operating Frequency control

Parameter	Symbol	Value	Unit
Proportional gain	K_p	10	mA^{-1}
Integral gain	K_i	0.05	$\text{mA}^{-1}\text{ms}^{-1}$
Derivative gain	K_d	0	mA^{-1}ms
Integral term limit	M_I	3,000	N.A.
PID output limit	M_{PID}	20,000	N.A.

Figure 209. Phase control signals to Full Bridge inverter

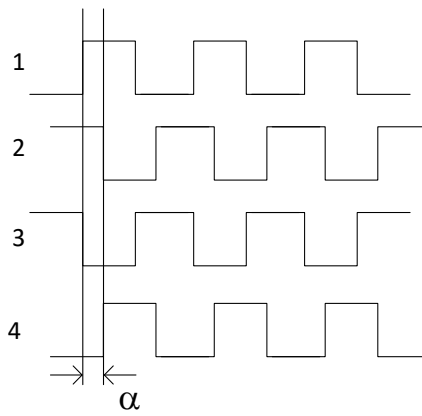

Figure 210. Duty control signals to Half Bridge inverter

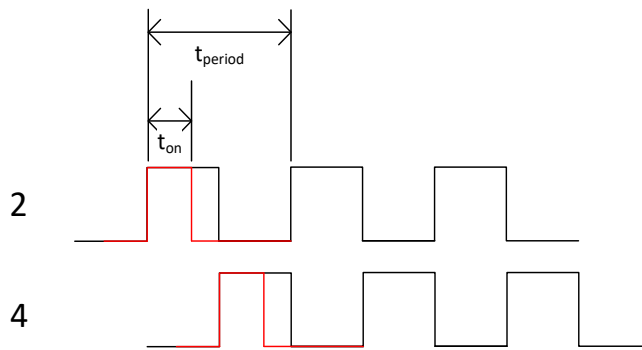

Table 143. Operating Frequency dependent scaling factor

Frequency Range [kHz]	Scaling Factor S_V [Hz]
110 to 130	1
130 to 140	1.5
140 to 160	2
160 to 180	3
180 to 205	5

Table 144. PID parameters for phase control

Parameter	Symbol	Value	Unit
Proportional gain	K_p	1	mA^{-1}
Integral gain	K_i	0.01	$\text{mA}^{-1}\text{ms}^{-1}$
Derivative gain	K_d	0	mA^{-1}ms
Integral term limit	M_I	3,000	N.A.
PID output limit	M_{PID}	20,000	N.A.
Scaling factor	S_V	0.036	°

Table 145. PID parameters for duty cycle control

Parameter	Symbol	Value	Unit
Proportional gain	K_p	1	mA^{-1}
Integral gain	K_i	0.01	$\text{mA}^{-1}\text{ms}^{-1}$
Derivative gain	K_d	0	mA^{-1}ms
Integral term limit	M_I	3,000	N.A.
PID output limit	M_{PID}	20,000	N.A.
Scaling factor	S_V	-0.002	%

2.4.7.3 Information interface

The Not Res Sens Bit in the Configuration Packet shall be set to ZERO.

2.4.8 Power Transmitter design MP-A8

Figure 211 illustrates the functional block diagram of Power Transmitter design MP-A8. This design consists of two major functional units, namely a Power Conversion Unit and a Communications and Control Unit.

Figure 211. Functional block diagram of Power Transmitter design MP-A8

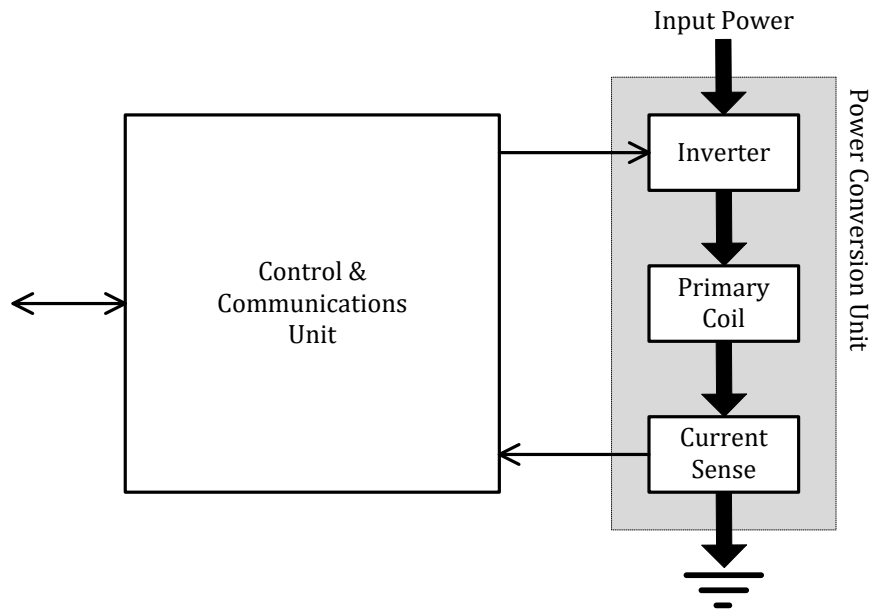

The Power Conversion Unit on the right-hand side of Figure 211 comprises the analog parts of the design. The inverter converts the DC input to an AC waveform that drives a resonant circuit consisting of the Primary Coil plus a series capacitor. Finally, the current sense monitors the Primary Coil current.

The Communications and Control Unit on the left-hand side of Figure 211 comprises the digital logic part of the design. This unit receives and decodes messages from the Power Receiver, executes the relevant power control algorithms and protocols, and drives the frequency of the AC waveform to control the power transfer. The Communications and Control Unit also interfaces with other subsystems of the Base Station, e.g. for user interface purposes.

2.4.8.1 Mechanical details

This section defines the Primary Coil, the Shielding, the Interface Surface, and the alignment aid for Power Transmitter design MP-A8.

2.4.8.1.1 Primary Coil

The Primary Coil is of the wire-wound type, and consists of type 2 litz wire having 180 strands of no. 42 AWG (0.06 mm diameter), or equivalent. As shown in Figure 4, the Primary Coil has a rectangular shape and consists of a single layer. Table 1 lists the dimensions of the Primary Coil.

Figure 212. Primary Coil of Power Transmitter design MP-A8

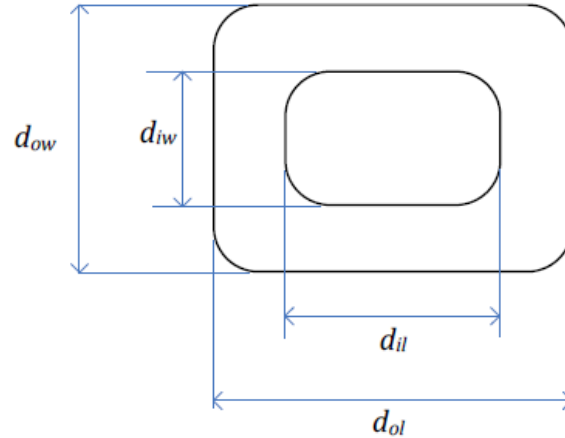
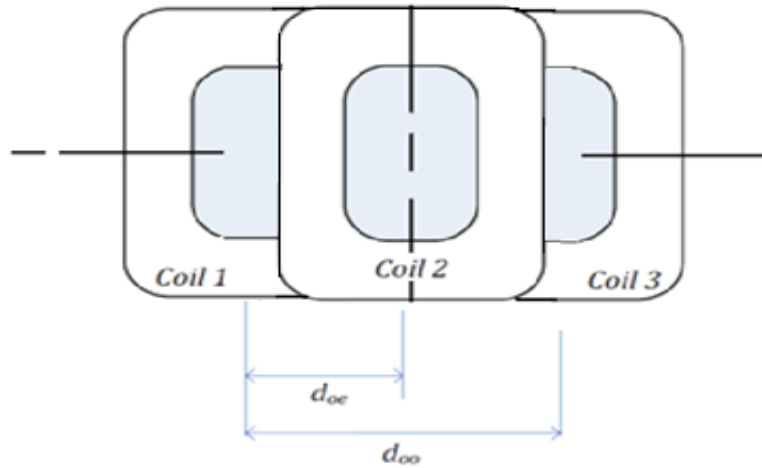

Table 146. Primary Coil parameters of Power Transmitter design MP-A8

Parameter	Symbol	Value
Outer length	d_{ol}	$51.0^{\pm 1.0}$ mm
Inner length	d_{il}	$27.5^{\pm 0.5}$ mm
Outer width	d_{ow}	$43.0^{\pm 1.0}$ mm
Inner width	d_{iw}	$19.5^{\pm 0.5}$ mm
Thickness	d_c	$1.6^{\pm 0.5}$ mm
Number of turns per layer	N	10
Number of layers	-	1

Power Transmitter design MP-A8 contains at least one Primary Coil. The use of multiple Primary Coils enables one-dimensional freedom of positioning. For that purpose, odd-numbered Primary Coils are placed in a row with a displacement of $d_{oo} = 44.0^{\pm 1.0}$ mm between their centers. Even-numbered Primary Coils are placed in a similar row on top of the odd numbered Primary Coils with a displacement of $d_{oe} = 22.0^{\pm 1.0}$ mm. Figure 213 shows this arrangement using three Primary Coils.

Figure 213. Primary Coil of Power Transmitter design MP-A8



2.4.8.1.2 Shielding

As shown in Figure 214, soft-magnetic material protects the Base Station from the magnetic field that is generated in the Primary Coil. The Shielding extends to at least 2 mm beyond the outer diameter of the Primary Coil, has a thickness of at least 2.0 mm, and is placed below the Primary Coil at a distance of at most $d_s = 1.0$ mm. This version of *Part 4: Reference Designs* limits the composition of the Shielding to a Ni-Zn or Mn-Zn ferrite core from any supplier.

Figure 214. Primary Coil assembly of Power Transmitter design MP-A8

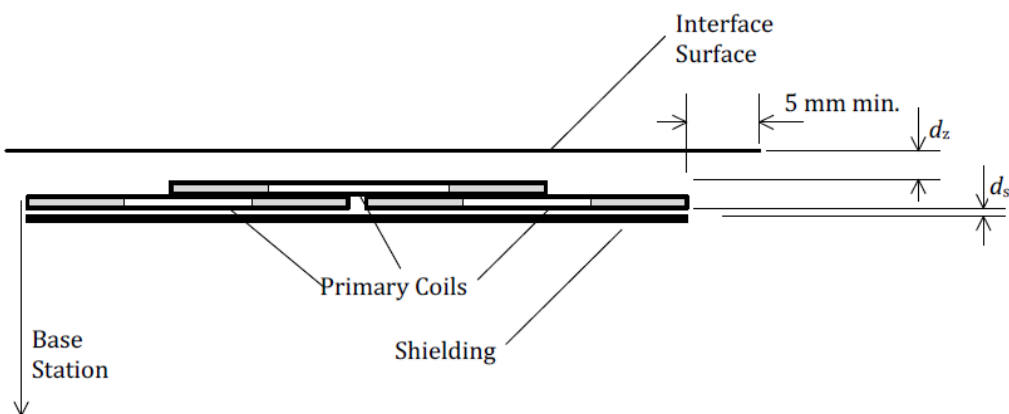

2.4.8.1.3 Interface Surface

As shown in Figure 214, the distance from the Primary Coil to the Interface Surface of the Base Station is $d_z = 2.0_{-0.25}^{+0.5}$ mm, across the top face of the Primary Coil. In addition, the Interface Surface of the Base Station extends at least 5.0 mm beyond the outer diameter of the Primary Coil.

NOTE This Primary-Coil-to-Interface-Surface distance implies that the tilt angle between the Primary Coil and a flat Interface Surface is at most 1.0° . Alternatively, in case of a non-flat Interface Surface, this Primary-Coil-to-Interface-Surface distance implies a radius of curvature of the Interface Surface of at least 317 mm, centered on the Primary Coil. See Figure 214.

2.4.8.1.4 Alignment aid

The user manual of a Base Station containing a type MP-A8 Power Transmitter shall provide information about the location of its Active Area(s).

For the best user experience, it is recommended to employ at least one user feedback mechanism during Mobile Device positioning to help alignment.

NOTE Examples of Base Station alignment aids to assist the user positioning of the Mobile Device include:

- A marked Interface Surface to indicate the location of the Active Area(s)—e.g. a logo or other visual marking, lighting, etc.
- A visual feedback display—e.g. by means of illuminating an LED to indicate proper alignment.
- An audible or tactile feedback mechanism.

2.4.8.1.5 Inter-coil separation

If the Base Station contains multiple type MP-A8 Power Transmitters, the Primary Coils of any pair of those Power Transmitters shall have a center-to-center distance of at least 50 mm.

2.4.8.2 Electrical details

As shown in Figure 215, Power Transmitter design MP-A8 uses a full-bridge inverter to drive the individual Primary Coil and a series capacitor. Within the Operating Frequency range specified below, the assembly of Primary Coil and Shielding has an inductance of $7.5^{\pm 10\%}$ μH for cells closest to the Interface Surface and an inductance of $8.5^{\pm 10\%}$ μH for cells furthest from the Interface Surface. The value of the series capacitance is $420^{\pm 5\%}$ nF for cells closest to the Interface Surface and $400^{\pm 5\%}$ nF for cells farthest from the Interface Surface. The input voltage to the full bridge inverter is $12^{\pm 1}$ V.

NOTE Near resonance, the voltage developed across the series capacitance can reach levels exceeding 200 V pk-pk.

Power Transmitter design MP-A8 uses the Operating Frequency and the phase difference of the full-bridge inverter's driving signals (see Figure 216), or uses the Operating Frequency and duty cycle of the half-bridge inverter's driving signals (see Figure 217) in order to control the amount of power that is transferred. For this purpose, the Operating Frequency range of the inverter is $f_{op} = 110$ kHz to 205 kHz with a driving signal phase difference of $\alpha = 0^\circ$ to 133° or a duty cycle of $D = 10\%$ to 50% . A higher Operating Frequency, bigger phase difference, or lower duty cycle will result in the transfer of a lower amount of power. In order to achieve a sufficiently accurate adjustment of the amount of power that is transferred, a type MP-A8 Power Transmitter shall control the Operating Frequency with a minimum resolution of:

- $0.01 \cdot f_{op} - 0.7$ kHz for f_{op} in the 110 kHz to 175 kHz range;
- $0.015 \cdot f_{op} - 1.58$ kHz for f_{op} in the 175 kHz to 205 kHz range.

In addition, a type MP-A8 Power Transmitter shall control the driving-signal phase difference with a resolution of 0.18° or better. Moreover, a type MP-A8 Power Transmitter shall control the driving-signal duty cycle with a resolution of 0.1% or better.

When a type MP-A8 Power Transmitter first applies a Power Signal (Digital Ping), it shall use an initial input voltage to the half-bridge inverter of $12^{\pm 1}$ V and an initial Operating Frequency range of 170 kHz to 180 kHz and a duty cycle of 50% .

Control of the power transfer shall proceed using the PID algorithm, which is defined in *Parts 1 and 2: Interface Definitions*. The controlled variable introduced in the definition of that algorithm represents the Operating Frequency, operating duty cycle, or operating phase difference depending on the required power of the Power Receiver. In order to guarantee sufficiently accurate power control, a type MP-A8 Power Transmitter shall determine the amplitude of the Primary Coil current—which is equal to the Primary Coil current—with a resolution of 7 mA or better. Finally, Table 147, Table 148, Table 149, Table 150, and Table 151 provide the values of several parameters that are used in the PID algorithm.

The type MP-A8 Power Transmitter shall handle the different control methodologies as follows.

- At an Operating Frequency of 205 kHz, the Power Transmitter shall operate in half-bridge mode, using duty cycle control with a range of 10% to 50% .
- At Operating Frequencies between 172 kHz and 205 kHz, the Power Transmitter shall operate in half-bridge mode at 50% duty cycle, using Operating Frequency control.
- At an Operating Frequency of 172 kHz, the Power Transmitter shall operate in full-bridge mode with a phase difference of 0° to 133° .
- At Operating Frequencies below 172 kHz, the Power Transmitter shall operate in full-bridge mode with a phase difference of 0° using Operating Frequency control.

When the Power Transmitter reaches the 172 kHz transition point, it shall

- switch from half-bridge mode to full-bridge mode at a 133° phase difference if moving down in Operating Frequency, or
- switch from full-bridge mode at a 133° phase difference to half-bridge mode if moving up in Operating Frequency.

If the Power Transmitter reaches the 172 kHz transition point in the middle of a PID control loop, the Power Transmitter shall terminate the control loop and wait for subsequent Control Error Packets.

Figure 215. Electrical diagram (outline) of Power Transmitter design MP-A8

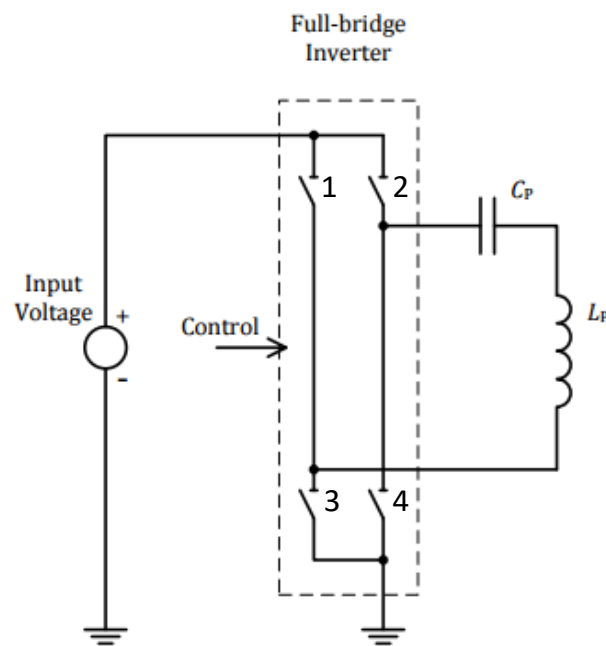

Table 147. PID parameters for Operating Frequency control (half bridge)

Parameter	Symbol	Value	Unit
Proportional gain	K_p	10	mA^{-1}
Integral gain	K_i	1	$\text{mA}^{-1}\text{ms}^{-1}$
Derivative gain	K_d	1	mA^{-1}ms
Integral term limit	M_i	3,000	N.A.
PID output limit	M_{PID}	20,000	N.A.

Table 148. PID parameters for Operating Frequency control (full bridge)

Parameter	Symbol	Value	Unit
Proportional gain	K_p	5	mA^{-1}
Integral gain	K_i	1	$\text{mA}^{-1}\text{ms}^{-1}$
Derivative gain	K_d	1	mA^{-1}ms
Integral term limit	M_i	3,000	N.A.
PID output limit	M_{PID}	20,000	N.A.

Figure 216. Phase difference control signals to full bridge inverter

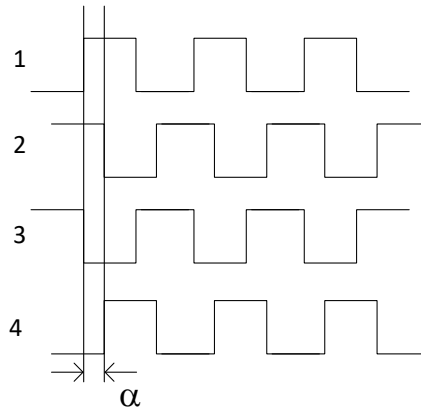

Figure 217. Duty cycle control signals to half bridge inverter

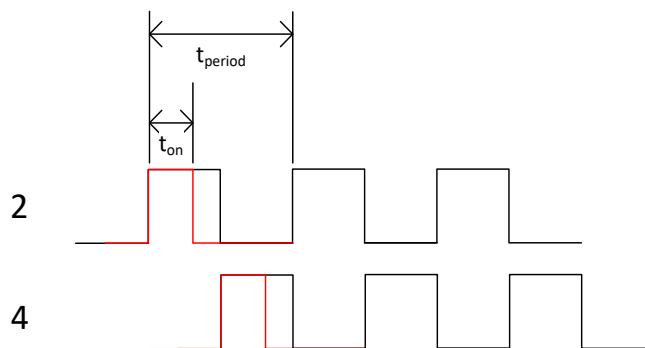

Table 149. Operating Frequency dependent scaling factor

Frequency Range [kHz]	Scaling Factor S_V [Hz]
110 to 140	1.5
140 to 160	2
160 to 180	3
180 to 205	5

Table 150. PID parameters for phase difference control

Parameter	Symbol	Value	Unit
Proportional gain	K_p	1	mA^{-1}
Integral gain	K_i	1	$\text{mA}^{-1}\text{ms}^{-1}$
Derivative gain	K_d	0	mA^{-1}ms
Integral term limit	M_I	3,000	N.A.
PID output limit	M_{PID}	20,000	N.A.
Scaling factor	S_V	0.009	°

Table 151. PID parameters for duty cycle control

Parameter	Symbol	Value	Unit
Proportional gain	K_p	10	mA^{-1}
Integral gain	K_i	1	$\text{mA}^{-1}\text{ms}^{-1}$
Derivative gain	K_d	0	mA^{-1}ms
Integral term limit	M_I	3,000	N.A.
PID output limit	M_{PID}	20,000	N.A.
Scaling factor	S_V	-0.01	%

2.4.8.3 Information interface

The Not Res Sens Bit in the Configuration Packet shall be set to ZERO.

2.4.9 Power Transmitter design MP-B1

Figure 218 illustrates the functional block diagram of Power Transmitter design MP-B1, which consists of two major functional units, namely a Power Conversion Unit and a Communications and Control Unit.

Figure 218. Functional block diagram of Power Transmitter design MP-B1

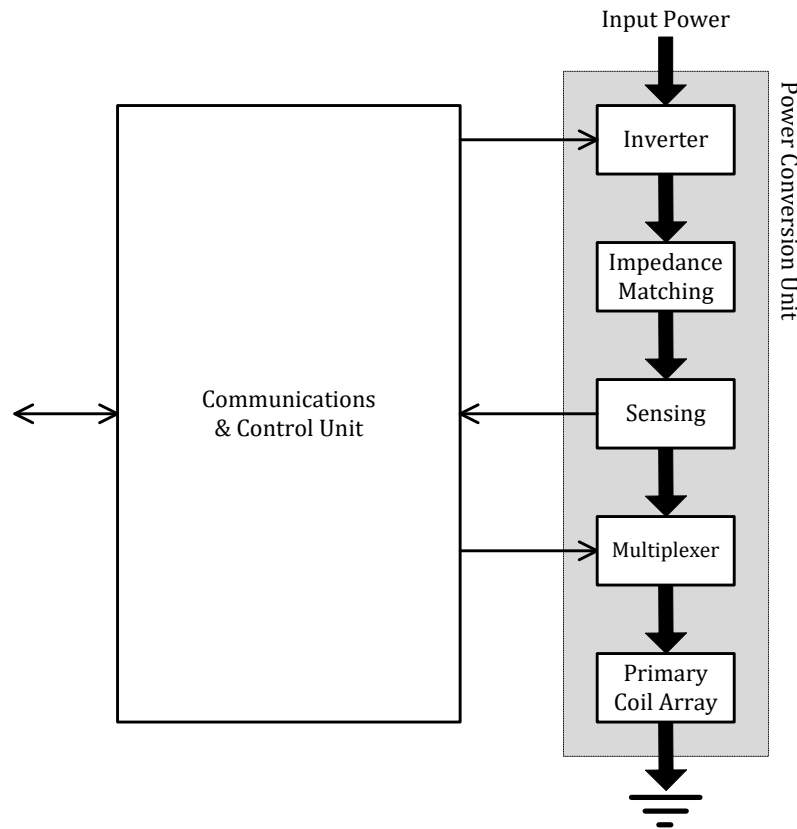

The Power Conversion Unit on the right-hand side of Figure 218 comprises the analog parts of the design. The design uses an array of partly overlapping Primary Coils to provide for Free Positioning. Depending on the position of the Power Receiver, the multiplexer connects and/or disconnects the appropriate Primary Coil(s). The impedance matching network forms a resonant circuit with the parts of the Primary Coil array that are connected. The sensing circuits monitor (amongst others) the Primary Cell current and voltage, and the inverter converts the DC input to an AC waveform that drives the Primary Coil array.

The Communications and Control Unit on the left-hand side of Figure 218 comprises the digital logic part of the design. This unit receives and decodes messages from the Power Receiver, configures the multiplexer to connect the appropriate parts of the Primary Coil array, executes the relevant power control algorithms and protocols, and drives the inverter to control the amount of power provided to the Power Receiver. The Communications and Control Unit also interfaces with the other subsystems of the Base Station, e.g. for user interface purposes.

2.4.9.1 Mechanical details

Power Transmitter design MP-B1 includes a Primary Coil array as defined in Section 2.3.7.1.1, Shielding as defined in Section 2.3.7.1.2, and an Interface Surface as defined in Section 2.3.7.1.3.

2.4.9.1.1 Primary Coil array

The Primary Coil design of the MP-B1 is identical to the Primary Coil array of the type B7 Power Transmitter array and consists of partly-overlapping, rectangular-shaped planar coils. In order to keep the inductance of each coil similar in the final assembly there are two coils specified for this transmitter type, Primary Coil A and Primary Coil B. On the left side of Figure 219 is a top view of Primary Coil A (left), which consists of a 17 AWG (1.2 mm diameter) wire that runs through 9 rectangular-shaped turns in a single layer. On the right is a top view of Primary Coil B, which consists of a 17 AWG (1.2 mm diameter) wire that runs through 10 rectangular-shaped turns in a single layer. Another realization of a single Primary Coil A or B is to construct it from litz wire having 105 strands of no. 40 AWG (0.08 mm diameter), or equivalent. Table 152 lists the relevant parameters of the coils shown in Figure 219.

NOTE Primary Coil B can be constructed from Primary Coil A by adding one inner turn, conversely, Primary Coil A can be constructed from Primary Coil B by removing one inner turn.

In this Primary Coil array the coils closest to the shielding shall be according to Primary Coil A, and the coils closest to the Interface Surface shall be according to Primary Coil B. Moreover, a transmitter execution that uses only one Primary Coil shall use Primary Coil A.

Figure 219. Top view of Primary Coil A (left) and Primary Coil B (right) of Power Transmitter design MP-B1

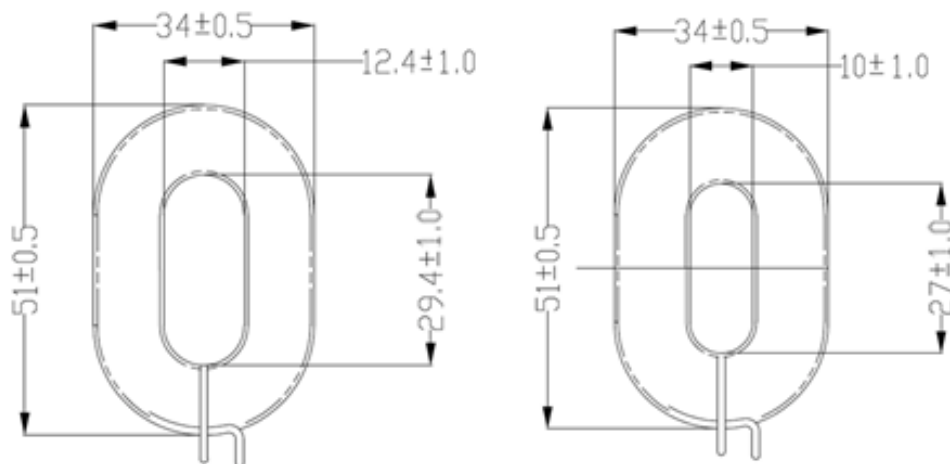

Table 152. Primary Coil parameters of Power Transmitter design MP-B1

Parameter	Symbol	Value
<i>Primary Coil A (closest to the shielding)</i>		
Outer width	w_o	$34.0^{+0.5}_{-0.5}$ mm
Outer length	l_o	$51.0^{+0.5}_{-0.5}$ mm
Inner width	w_i	$12.4^{+1.0}_{-1.0}$ mm
Inner length	l_i	$29.4^{+1.0}_{-1.0}$ mm
Number of turns	N	9
<i>Primary Coil B (closest to Interface Surface)</i>		
Outer width	w_o	$34.0^{+0.5}_{-0.5}$ mm
Outer length	l_o	$51.0^{+0.5}_{-0.5}$ mm
Inner width	w_i	$10.0^{+1.0}_{-1.0}$ mm
Inner length	l_i	$27.0^{+1.0}_{-1.0}$ mm
Number of turns	N	10

Power Transmitter design MP-B1 enables one-dimensional freedom of positioning. For that purpose, the Primary Coils are placed in a row, such that there is an overlap of approximately 50% of the area. Each Primary Coil (except for an execution that uses only one Primary Coil) overlaps with one other Primary Coils in a different layer. Figure 220 shows the layout of an example execution of the Primary Coil array using four Primary Coils. Table 153 lists the relevant parameters of the Primary Coil array.

Figure 220. Example of Power Transmitter design MP-B1 in a 4-coil execution

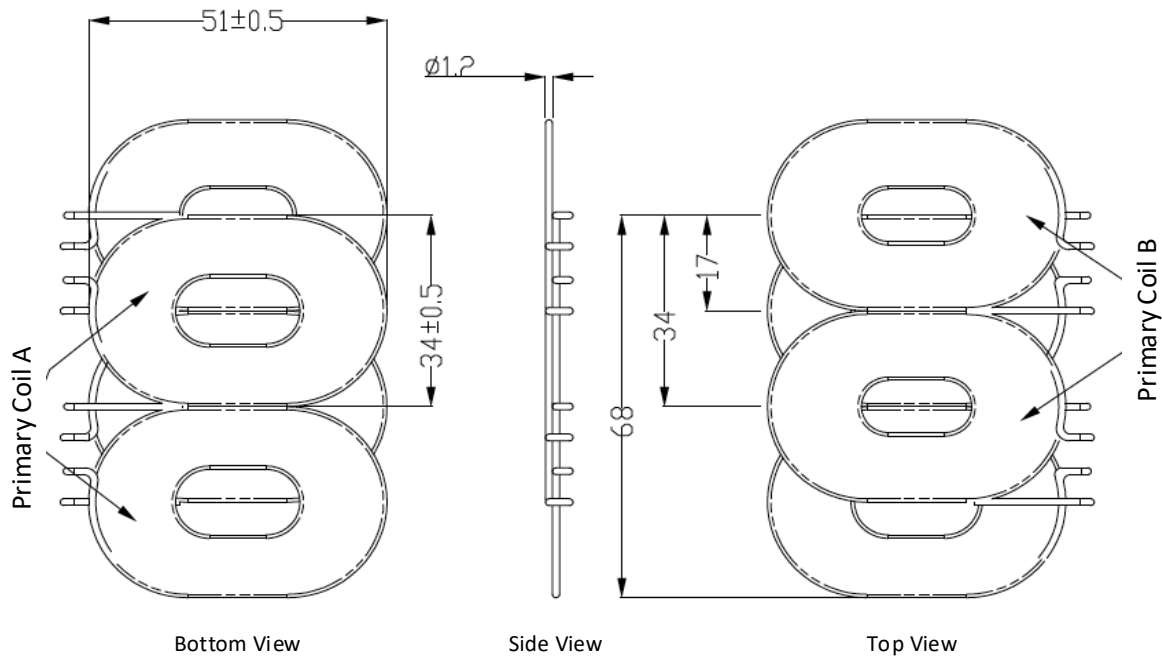

Table 153. Primary Coil array parameters of Power Transmitter design MP-B1

Parameter	Symbol	Value
Center-to-center distance	d_h	$34.0^{\pm 0.5}$ mm
Offset 2 nd layer array	t_2	$17.0^{\pm 0.5}$ mm
Litz-layer thickness	d_c	$1.2^{\pm 0.5}$ mm

2.4.9.1.2 Shielding

As shown in Figure 221, Transmitter design MP-B1 employs Shielding to protect the Base Station from the magnetic field that is generated in the Primary Coil array. The Shielding extends to at least 1 mm beyond the outer edges of the Primary Coil array, and is placed at a distance of at most $d_s = 0.5$ mm below the Primary Coil array.

The Shielding consists of soft magnetic material that has a thickness of at least 0.5 mm. This version of *Part 4: Reference Designs* limits the composition of the Shielding to any Mn-Zn (for example, PC44 from TDK Corporation).

Figure 221. Primary Coil array assembly of Power Transmitter design MP-B1, cross-sectional view

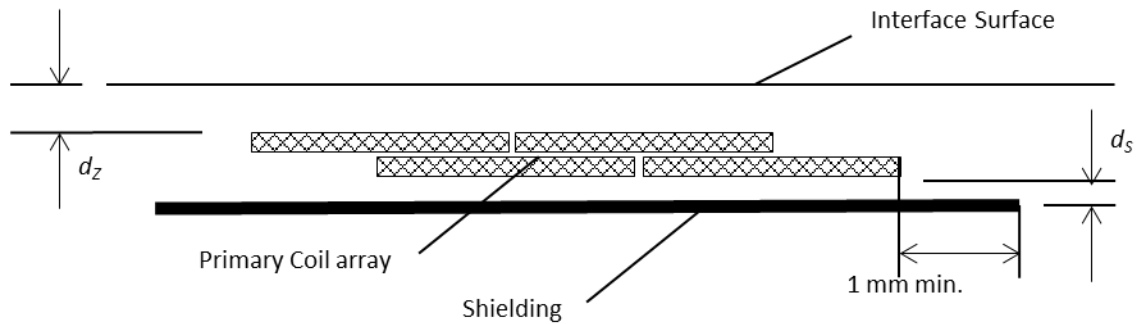

2.4.9.1.3 Interface Surface

As shown in Figure 221, the distance from the Primary Coil array to the Interface Surface of the Base Station is $d_z = 2^{\pm 0.5}$ mm, across the top face of the Primary Coil array. In addition, the Interface Surface extends at least 2 mm beyond the outer edges of the Primary Coil array.

2.4.9.2 Electrical details

As shown in Figure 222, Power Transmitter design MP-B1 uses a full-bridge inverter to drive the Primary Coil array. In addition, Power Transmitter design MP-B1 uses a multiplexer to select the position of the Active Area. The multiplexer shall configure the Primary Coil array in such a way that one or two Primary Coils are connected—in parallel—to the driving circuit. The connected Primary Coils together constitute a Primary Cell. In the case that two Primary Coils are selected, these two Primary Coils shall have an overlap of approximately 50% of the area of a single Primary Coil.

Figure 222. Electrical diagram (outline) of Power Transmitter design MP-B1

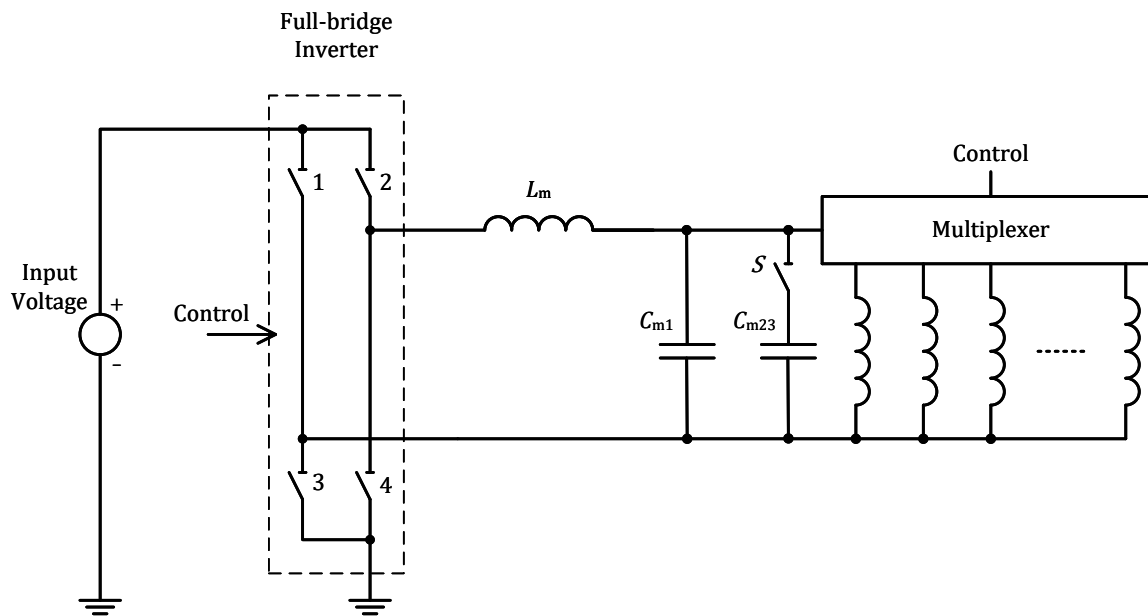

Within the Operating Frequency range $f_{op} = 115^{\pm 5}$ kHz, the assembly of Primary Coil array and Shielding has an inductance of $6.1^{\pm 0.6}$ μH for each individual Primary Coil. The capacitances in the impedance-matching circuit are $C_{m1} = 300^{\pm 5\%}$ nF and C_{m23} is in the range of $100^{-5\%}$ to $300^{+5\%}$ nF. The inductance in the impedance-matching circuit is $L_m = 3.8^{\pm 5\%}$ μH . Switch S is open if the Primary Cell consists of a single Primary Coil; otherwise, switch S is closed. The input voltage to the full-bridge inverter is $15^{\pm 5\%}$ V.

NOTE The voltage across the capacitance C_m can reach levels exceeding 40 V pk-pk.

Power Transmitter design MP-B1 uses the phase difference between the control signals to two halves of the full-bridge inverter to control the amount of power that is transferred (see Figure 223). For this purpose, the range of the phase difference α is $0 \dots 180^\circ$ —with a larger phase difference resulting in a lower power transfer. In order to achieve a sufficient accurate adjustment of the power that is transferred, a type MP-B1 Power Transmitter shall be able to control the phase difference with a resolution of 0.42° or better. When a type MP-B1 Power Transmitter first applies a Power Signal (see the *Digital Ping* section in *Parts 1 and 2: Interface Definitions*), it shall use an initial phase difference of 150° .

Figure 223. Control signals to the inverter

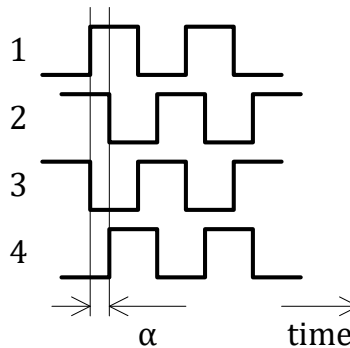

Control of the power transfer shall proceed using the PID algorithm, which is defined in the *Power transfer control* section in *Parts 1 and 2: Interface Definitions*. The controlled variable $v^{(i)}$ introduced in the definition of that algorithm represents the phase difference between the two halves of the full-bridge inverter. In order to guarantee sufficiently accurate power control, a type MP-B1 Transmitter shall determine the amplitude of the current into the Primary Cell with a resolution of 5 mA or better. In addition to the PID algorithm, a type MP-B1 Power Transmitter shall limit the current into the Primary Cell to at most 4 A RMS in the case that the Primary Cell consists of two Primary Coils, or at most 3 A RMS in the case that the Primary Cell consists of one Primary Coil. Finally, Table 154 provides the values of several parameters that are used in the PID algorithm.

Table 154. Power control parameters for Power Transmitter design MP-B1

Parameter	Symbol	Value	Unit
Proportional gain	K_p	1	mA^{-1}
Integral gain	K_i	0	$\text{mA}^{-1}\text{ms}^{-1}$
Derivative gain	K_d	0	mA^{-1}ms
Integral term limit	M_i	N.A.	N.A.
PID output limit	M_{PID}	2,000	N.A.
Scaling factor	S_v	0.01	$^\circ$

2.4.9.3 Scalability

Power Transmitter Design MP-B1 offers the same scalability options as Power Transmitter design B1. See Section 2.3.1, *Power Transmitter design B1*.

3 Power Receiver reference designs (Informative)

3.1 Power Receiver example 1 (5W)

The design of Power Receiver example 1 is optimized to directly charge a single cell lithium-ion battery at constant current or voltage.

3.1.1 Mechanical details

This Section 3.1.1 provides the mechanical details of Power Receiver example 1.

3.1.1.1 Secondary Coil

The Secondary Coil of Receiver example 1 is of the wire-wound type, and consists of no. 26 AWG (0.41 mm diameter) litz wire having 26 strands of no. 40 AWG (0.08 mm diameter). As shown in Figure 224, the Secondary Coil has a rectangular shape and consists of a single layer. Table 155 lists the dimensions of the Secondary Coil.

Figure 224. Secondary Coil of Power Receiver example 1

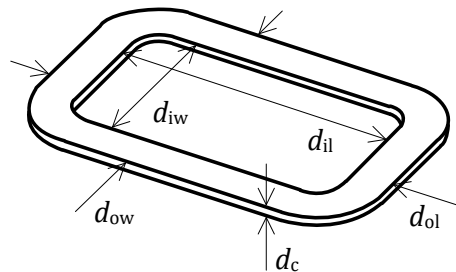

Table 155. Secondary Coil parameters of Power Receiver example 1

Parameter	Symbol	Value
Outer length	d_{ol}	$44.25^{\pm 0.25}$ mm
Inner length	d_{il}	$28.75^{\pm 0.25}$ mm
Outer width	d_{ow}	$30.25^{\pm 0.25}$ mm
Inner width	d_{iw}	$14.75^{\pm 0.25}$ mm
Thickness	d_c	0.6 mm
Number of turns per layer	N	14
Number of layers	–	1

3.1.1.2 Shielding

As shown in Figure 225, Power Receiver example 1 employs Shielding. The Shielding should be Ni-Zn or Mn-Zn ferrite and should be at least 1.0 mm thick. The Shielding has a size of $d_1 \times d_w = 52^{\pm 1} \times 35^{\pm 1} \text{ mm}^2$, and is centered directly on the top face of the Secondary Coil such that the long side of the Secondary Coil and the Shielding are aligned.

Figure 225. Secondary Coil and Shielding assembly of Power Receiver example 1

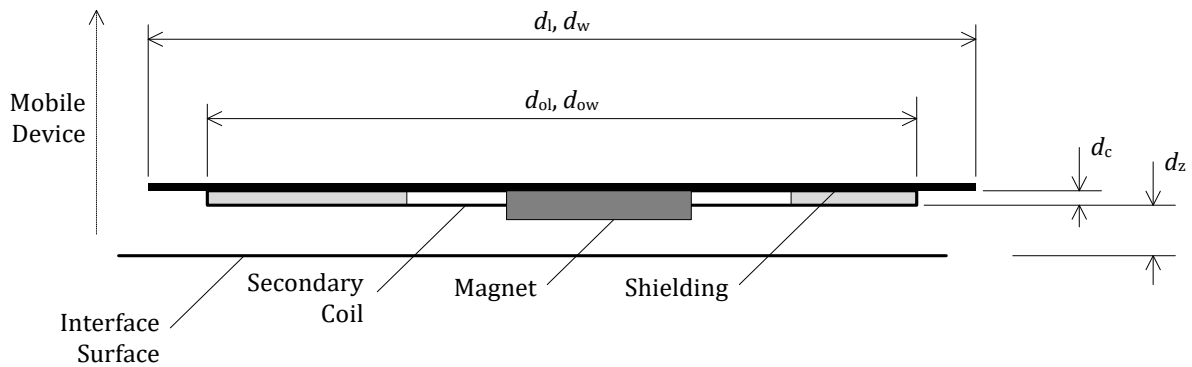

3.1.1.3 Interface Surface

The distance from the Secondary Coil to the Interface Surface of the Mobile Device is $d_z = 2.5 \text{ mm}$, uniform across the bottom face of the Secondary Coil.

3.1.1.4 Alignment aid

Power Receiver example 1 employs a bonded Neodymium magnet, which has its south pole oriented towards the Interface Surface. The diameter of the magnet is 15 mm, and its thickness is 1.2 mm.

3.1.2 Electrical details

At the secondary resonance frequency $f_S = 100$ kHz, the assembly of Secondary Coil, Shielding and magnet has inductance values $L_S = 15.3^{\pm 1} \mu\text{H}$ and $L'_S = 20.0^{\pm 1} \mu\text{H}$. The capacitance values in the dual resonant circuit are $C_S = 127^{\pm 1\%} \text{nF}$ and $C_d = 1.6^{\pm 5\%} \text{nF}$.

As shown in Figure 226, the rectification circuit consists of four diodes in a full bridge configuration and a low-pass filtering capacitance $C = 20 \mu\text{F}$.

The communications modulator consists of two equal capacitances $C_{cm} = 22^{\pm 5\%} \text{nF}$ in series with two switches. The resistance value $R = 10^{\pm 5\%} \text{k}\Omega$.

The subsystem connected to the output of Power Receiver example 1 is expected to consist of a single cell lithium-ion battery. This Power Receiver example 1 controls the output current and output voltage into the battery according to the common constant current to constant voltage charging profile. An example profile is indicated in Figure 227. The maximum output power to the battery is controlled to a 5 W level.

Figure 226. Electrical details of Power Receiver example 1

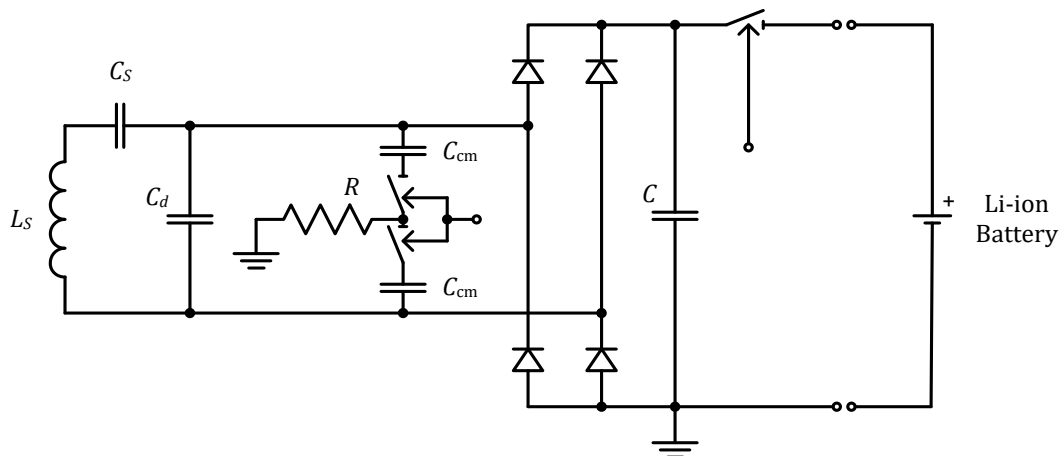
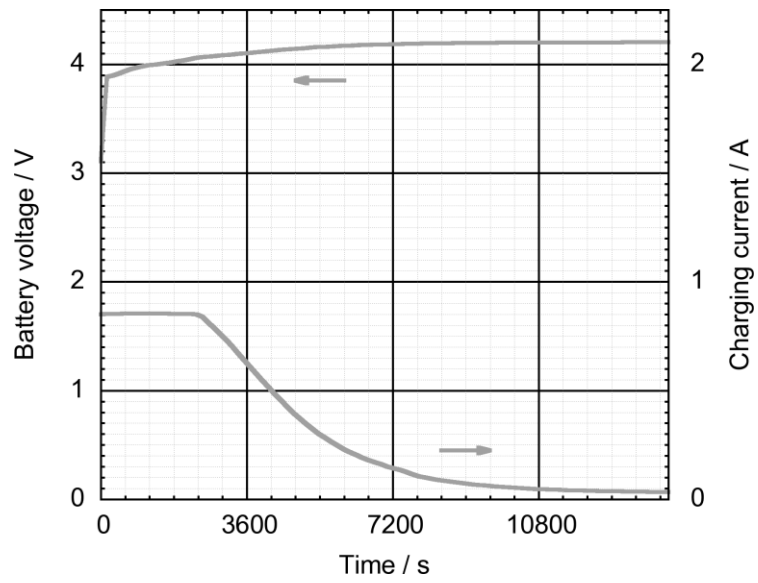

Figure 227. Li-ion battery charging profile



3.2 Power Receiver example 2 (5W)

The design of Power Receiver example 2 uses post-regulation to create a voltage source at the output of the Power Receiver.

3.2.1 Mechanical details

This section 3.2.1 provides the mechanical details of Power Receiver example 2.

3.2.1.1 Secondary Coil

The Secondary Coil of Power Receiver example 2 is of the wire-wound type, and consists of litz wire having 24 strands of no. 40 AWG (0.08 mm diameter). As shown in Figure 228, the Secondary Coil has a circular shape and consists of multiple layers. All layers are stacked with the same polarity. Table 156 lists the dimensions of the Secondary Coil.

Figure 228. Secondary Coil of Power Receiver example 2

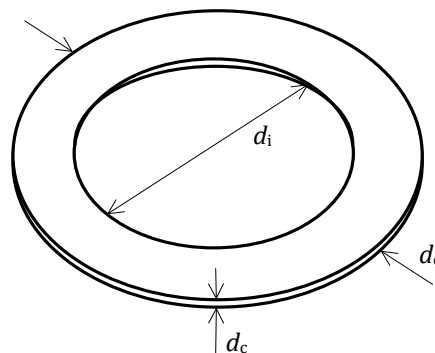

Table 156. Parameters of the Secondary Coil of Power Receiver example 2

Parameter	Symbol	Value
Outer diameter	d_o	$32^{\pm 0.25}$ mm
Inner diameter	d_i	$21.7^{\pm 0.6}$ mm
Thickness	d_c	$0.9^{\pm 0.2}$ mm
Number of turns per layer	N	9
Number of layers	-	2

3.2.1.2 Shielding

As shown in Figure 229, Power Receiver example 2 employs Shielding. The Shielding should be Ni-Zn or Mn-Zn ferrite and should be at least 0.8 mm thick. The Shielding has a size of $d_l \times d_w = 35^{\pm 1} \times 35^{\pm 1} \text{ mm}^2$, and is centered directly on the top face of the Secondary Coil.

Figure 229. Secondary Coil and Shielding assembly of Power Receiver example 2

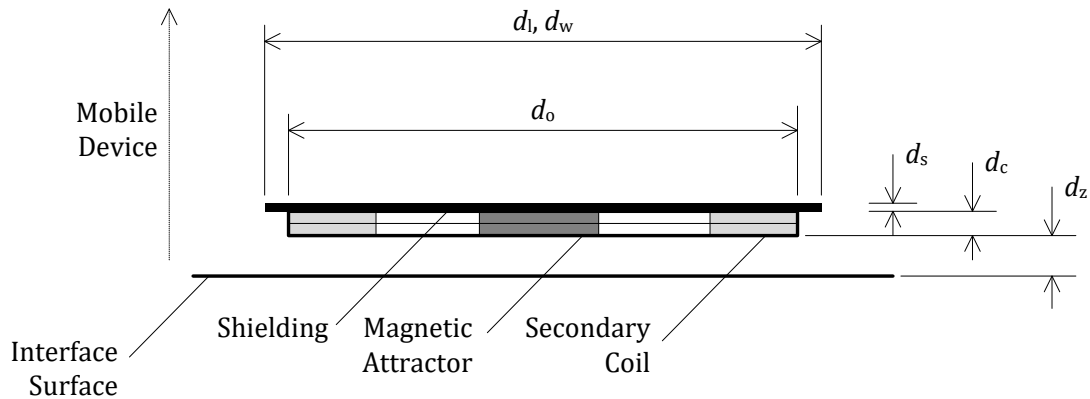

3.2.1.3 Interface Surface

The distance from the Secondary Coil to the Interface Surface of the Mobile Device is $d_z = 2 \text{ mm}$, uniform across the bottom face of the Secondary Coil.

3.2.1.4 Alignment aid

Power Receiver example 2 employs Shielding material (see section 3.2.1.2) as an alignment aid (see *Parts 1 and 2: Interface Definitions*). The diameter of this Shielding material is 10 mm, and its thickness is 0.8 mm.

3.2.2 Electrical details

At the secondary resonance frequency $f_s = 100$ kHz, the assembly of Secondary Coil and Shielding has an inductance values $L_S = 23.8^{\pm 1}$ μ H and $L'_s = 30.8^{\pm 1}$ μ H. The capacitance values in the dual resonant circuit are $C_S = 82^{\pm 5\%}$ nF and $C_d = 1.0^{\pm 5\%}$ nF.

As shown in Figure 230, the rectification circuit consists of four diodes in a full bridge configuration and a low-pass filtering capacitance $C = 20^{\pm 20\%}$ μ F.

The communications modulator consists of a $R_{cm} = 33^{\pm 5\%}$ Ω resistance in series with a switch.

The buck converter comprises the post-regulation stage of Power Receiver example 2. The Control and Communications Unit of the Power Receiver can disable the buck converter. This provides the output disconnect functionality. In addition, the Control and Communications Unit controls the input voltage V_r to the buck converter, such that $V_r = 7$ V.

The buck converter has a constant output voltage of 5 V and an output current

$$I_{\text{buck}} = \frac{\eta(P) \cdot P}{5 \text{ V}},$$

Where P is the output power of the buck converter, and $\eta(P)$ is the power dependent efficiency of the buck converter.

Figure 230. Electrical details of Power Receiver example 2

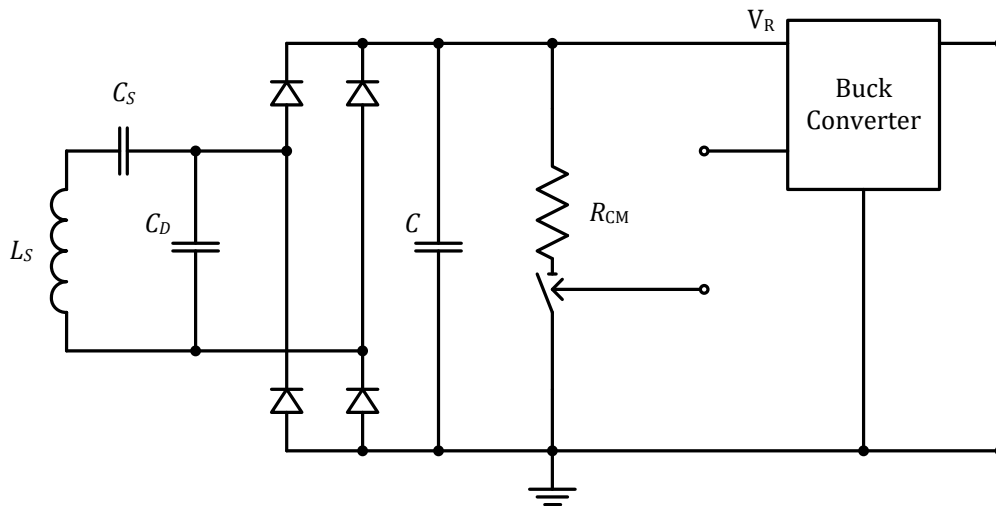

3.3 Power Receiver example 3 (8 W)

The design of Power Receiver example 3 uses post-regulation to create a voltage source at the output of the Power Receiver.

3.3.1 Mechanical details

This section provides the mechanical details of Power Receiver example 3.

3.3.1.1 Secondary Coil

The Secondary Coil of Power Receiver example 3 is of the wire-wound type, and consists of litz wire having 66 strands of no. 40 AWG (0.08 mm diameter). As shown in Figure 231, the Secondary Coil has a circular shape and consists of a single layer. Table 157 lists the dimensions and other parameters of the Secondary Coil.

Figure 231. Secondary Coil of Power Receiver example 3

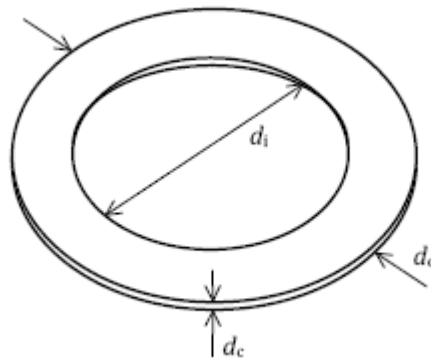

Table 157. Secondary Coil parameters of Power Receiver example 3

Parameter	Symbol	Value
Outer diameter	d_o	$47^{\pm 2}$ mm
Inner diameter	d_i	$24.25^{\pm 0.25}$ mm
Thickness	d_c	$0.9^{\pm 0.1}$ mm
Number of turns per layer	N	12
Number of layers	–	1

3.3.1.2 Shielding

As shown in Figure 232, Power Receiver example 3 employs Shielding. The Shielding should be Ni-Zn or Mn-Zn ferrite and should be $d_s = 1.0 \pm 0.25$ mm thick. The Shielding has a size of $d_{os} = 50 \pm 0.25$ mm, and is centered directly on the top face of the Secondary Coil.

Figure 232. Secondary Coil and Shielding assembly of Power Receiver example 3

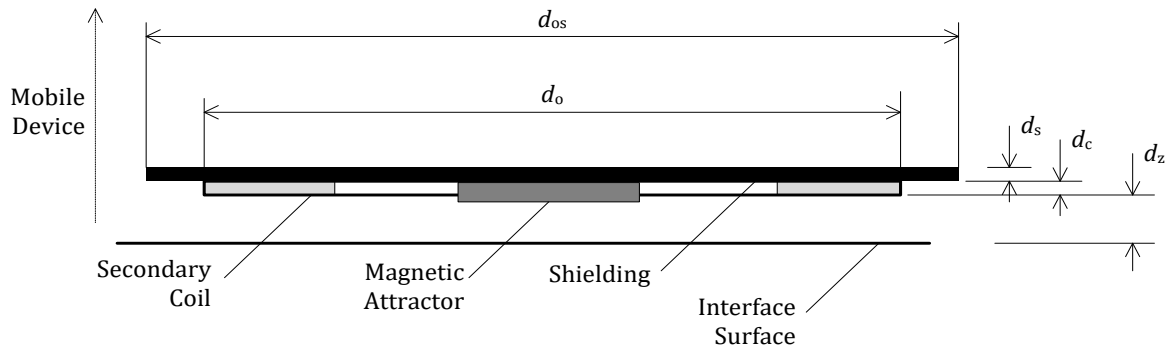

3.3.1.3 Interface Surface

The distance from the Secondary Coil to the Interface Surface of the Mobile Device is $d_z = 2.5$ mm, uniform across the bottom face of the Secondary Coil.

3.3.1.4 Alignment aid

Power Receiver example 3 employs Shielding material as a magnetic attractor. The diameter of this Shielding material is 20.0 ± 0.25 mm and its thickness is 1.27 ± 0.1 mm.

3.3.2 Electrical details

At the secondary resonance frequency $f_S = 100$ kHz, the assembly of Secondary Coil and Shielding has inductance values $L_S = 11.5^{\pm 1}$ μH and $L_S' = 15.7^{\pm 1}$ μH . The capacitance values in the dual resonant circuit are $C_S = 160^{\pm 5\%}$ nF and $C_d = 2.2^{\pm 5\%}$ nF.

As shown in Figure 233, the rectification circuit consists of four diodes in a full-bridge configuration with a low-pass filtering capacitance of $C = 33^{\pm 20\%}$ μF .

The communications modulator consists of two capacitors in series with two switches, each with a capacitance of $C_{cm} = 22^{\pm 10\%}$ nF.

The linear regulator comprises the post-regulation stage of Power Receiver example 3. The Control and Communications Unit of the Power Receiver can disable the regulator to provide output disconnect functionality. In addition, the Control and Communications Unit controls the input voltage to the regulator, such that $V_r = 5.8$ V.

The linear regulator has a constant output voltage of 5 V. The output current is

$$I_{\text{reg}} = \frac{P}{5 \text{ V}}$$

where P is the output power of the regulator. In this example, the output power is up to 8 W.

Figure 233. Electrical details of Power Receiver example 3

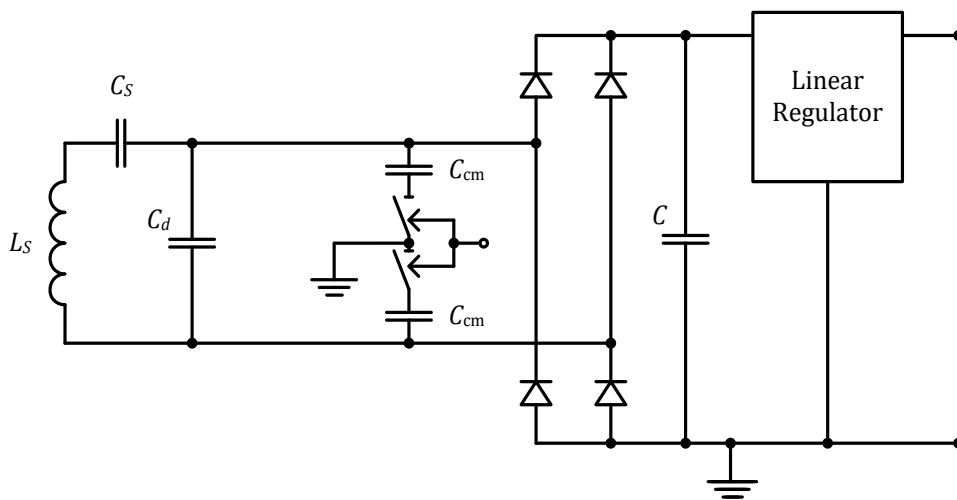

3.4 Power Receiver example 4 (15 W)

The design of Power Receiver example 4 uses post-regulation to create a voltage source at the output of the Power Receiver.

3.4.1 Mechanical details

This section provides the mechanical details of Power Receiver example 4.

3.4.1.1 Secondary Coil

The Secondary Coil of Power Receiver example 4 is of the wire-wound type, and consists of litz wire having 66 strands of no. 40 AWG (0.08 mm diameter). As shown in Figure 234, the Secondary Coil has a circular shape and consists of multiple layers. All layers are stacked with the same polarity. Table 158 lists the dimensions and other parameters of the Secondary Coil.

Figure 234. Secondary Coil of Power Receiver example 4

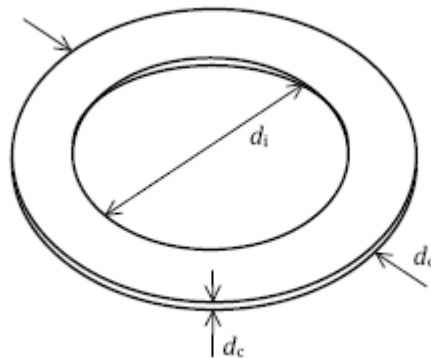

Table 158. Secondary Coil parameters of Power Receiver example 4

Parameter	Symbol	Value
Outer diameter	d_o	$47.0^{\pm 2}$ mm
Inner diameter	d_i	$28.0^{\pm 0.25}$ mm
Thickness	d_c	$1.8^{\pm 0.1}$ mm
Number of turns per layer	N	10
Number of layers	–	2

3.4.1.2 Shielding

As shown in Figure 235, Power Receiver example 4 employs Shielding. The Shielding should be Ni-Zn or Mn-Zn ferrite and should be $d_s = 1.0 \pm 0.25$ mm thick. The Shielding has a size of $d_{os} = 50 \pm 0.25$ mm, and is centered directly on the top face of the Secondary Coil.

Figure 235. Secondary Coil and Shielding assembly of Power Receiver example 4

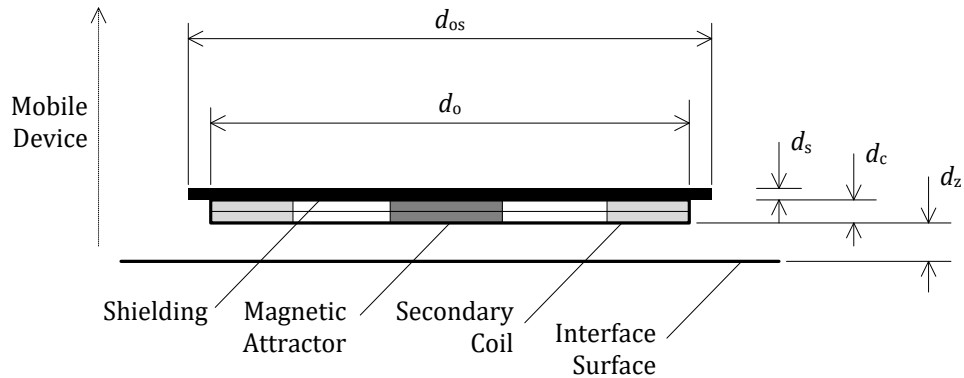

3.4.1.3 Interface Surface

The distance from the Secondary Coil to the Interface Surface of the Mobile Device is $d_z = 2.5$ mm, uniform across the bottom face of the Secondary Coil.

3.4.1.4 Alignment aid

Power Receiver example 4 employs Shielding material as a magnetic attractor. The diameter of this Shielding material is 20.0 ± 0.25 mm and its thickness is 1.91 ± 0.1 mm.

3.4.2 Electrical details

At the secondary resonance frequency $f_S = 100$ kHz, the assembly of Secondary Coil and Shielding has inductance values of $L_S = 33.6^{\pm 1}$ μH and $L_S' = 44.8^{\pm 1}$ μH . The capacitance values in the dual resonant circuit are $C_S = 56^{\pm 5\%}$ nF and $C_d = 0.8^{\pm 5\%}$ nF..

As shown in Figure 236, the rectification circuit consists of four diodes in a full-bridge configuration with a low-pass filtering capacitance of $C = 33^{\pm 20\%}$ μF .

The communications modulator consists of two capacitors in series with two switches, each with a capacitance of $R_{cm} = 30^{\pm 5\%}$ Ω

The buck converter comprises the post-regulation stage of Power Receiver example 4. The Control and Communications Unit of the Power Receiver can disable the buck converter to provide output disconnect functionality. In addition, the Control and Communications Unit controls the input voltage to the buck converter, such that $V_f = 12$ V.

The buck converter has a constant output voltage of 5 V. The output current is

$$I_{\text{out}} = \frac{P}{5 \text{ V}}$$

and the input current is

$$I_{\text{buck}} = \frac{P}{\eta(P) \cdot 12 \text{ V}}$$

where P is the output power of the buck converter, and $\eta(P)$ is the power-dependent efficiency of the buck converter. For this example, P may be as large as 15 W.

Figure 236. Electrical details of Power Receiver example 4

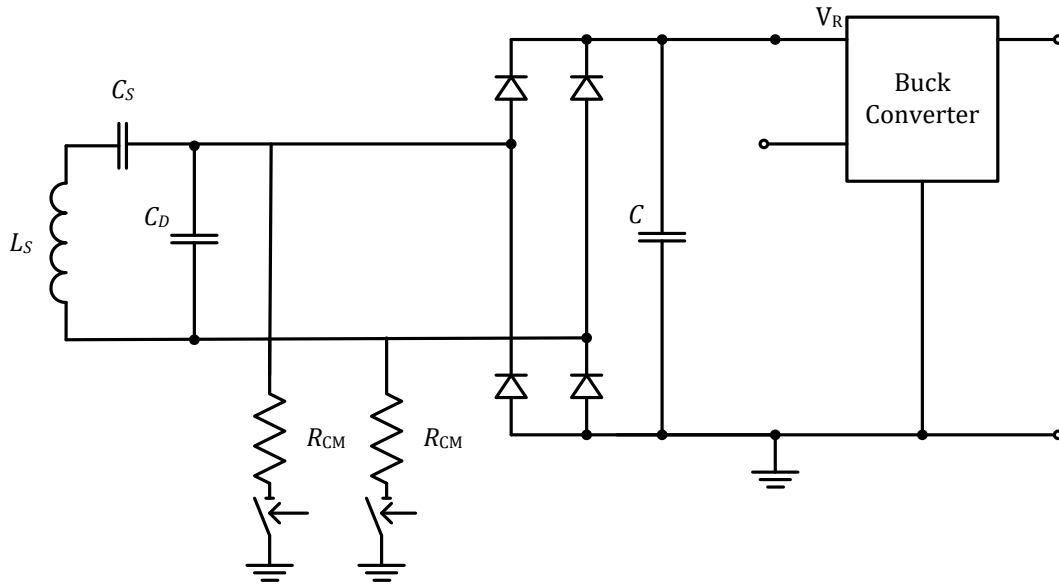

3.5 Power Receiver example 5 (12 W)

The design of Power Receiver example 5 uses post-regulation to create a voltage source at the output of the Power Receiver.

3.5.1 Mechanical details

This section provides the mechanical details of Power Receiver example 5.

3.5.1.1 Secondary Coil

The Secondary Coil of Power Receiver example 5 is of the wire-wound type, and consists of 30 AWG (0.26 mm diameter) bifilar wire. As shown in Figure 237, the Secondary Coil has a circular shape and consists of a single layer. Table 159 lists the dimensions and other parameters of the Secondary Coil.

Figure 237. Secondary Coil of Power Receiver example 5

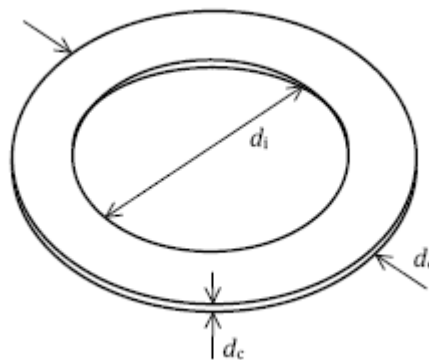

Table 159. Secondary Coil parameters of Power Receiver example 5

Parameter	Symbol	Value
Outer diameter	d_o	$40.0^{\pm 0.25}$ mm
Inner diameter	d_i	$22.0^{\pm 0.25}$ mm
Thickness	d_c	$0.29^{\pm 0.1}$ mm
Number of turns per layer	N	15
Number of layers	-	1

3.5.1.2 Shielding

As shown in Figure 238, Power Receiver example 5 employs Shielding. The Shielding should be Ni-Zn or Mn-Zn ferrite and should be $0.6^{\pm 0.25}$ mm thick. The Shielding has a size of $d_l \times d_w = 50.0^{\pm 0.25} \times 50.0^{\pm 0.25}$ mm² and is centered directly on the top face of the Secondary Coil.

Figure 238. Secondary Coil and Shielding assembly of Power Receiver example 5

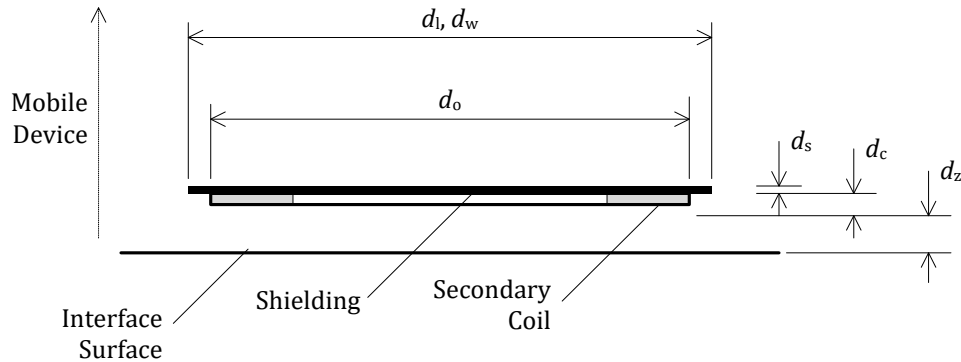

3.5.1.3 Interface Surface

The distance from the Secondary Coil to the Interface Surface of the Mobile Device is $d_z = 1.0$ mm, uniform across the bottom face of the Secondary Coil.

3.5.2 Electrical details

At the secondary resonance frequency $f_s = 100$ kHz, the Secondary Coil and Shielding assembly has inductance values of $L_s = 15.4^{\pm 1}$ μ H and $L'_s = 23.0^{\pm 1}$ μ H. The capacitance values in the dual resonant circuit are $C_s = 110^{\pm 5\%}$ nF and $C_d = 1.6^{\pm 5\%}$ nF.

As shown in Figure 239, the rectification circuit consists of four diodes in a full-bridge configuration with a low-pass filtering capacitance of $C = 10^{\pm 20\%}$ μ F.

The communications modulator consists of two capacitors in series with two switches, each with a capacitance of $C_m = 22^{\pm 10\%}$ nF.

The buck converter comprises the post-regulation stage of Power Receiver example 5. The Control and Communications Unit of the Power Receiver can disable the buck converter to provide output disconnect functionality. In addition, the Control and Communications Unit controls the input voltage to the buck converter, such that $V_r = 12$ V.

The buck converter has a constant output voltage of 5 V. The output current is

$$I_{out} = \frac{P}{5\text{ V}}$$

and the input current is

$$I_{buck} = \frac{P}{\eta(P) \cdot 12\text{ V}}$$

where P is the output power of the buck converter, and $\eta(P)$ is the power-dependent efficiency of the buck converter.

Figure 239. Electrical details of Power Receiver example 5

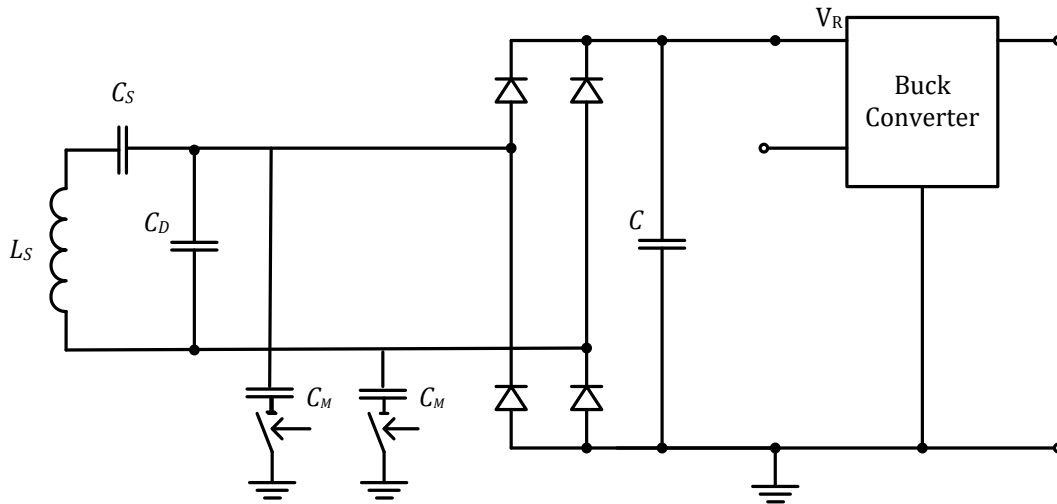

Annex A History of Changes

NOTE The changes listed in Table 160 are limited to technical updates and other changes of significance made in version 1.2.3. The table does not identify minor editorial changes such as typographical errors.

Table 160. Changes from version 1.2.2 to 1.2.3

Location	Old	New	Reason
Section 1.4.2, References	[List of documents referenced in specification]	Updated list of documents with links and other information about how to find them.	Editorial update
Section 1.5, Definitions, Guaranteed Power definition	—	New paragraph: “...Depending on the context, <i>Guaranteed Power</i> can refer to the Guaranteed Power value contained in the Power Transfer Contract, or it can refer to the Guaranteed Power Value field contained in the Power Transmitter Capability Packet.”	Change request #375
Section 1.5, Definitions, Transmitted Power definition	The total amount of power dissipated outside the Interface Surface of a Base Station, due to the magnetic field generated by the Power Transmitter.	The total amount of power, as measured by the Power Transmitter, that is dissipated outside the Interface Surface of a Base Station, due to the magnetic field generated by the Power Transmitter.	Change request #375
Section 1.6, Acronyms	—	New acronyms added: BPP, EPP; GPV, PPV, PTC-GP, TP	Editorial update; Change request #375
All Shielding sections for all Power Transmitter designs	Shielding thicknesses and specific materials were required.	Shielding thicknesses and materials are now only recommended. For example, “The Shielding should be Ni-Zn or Mn-Zn ferrite and should be at least 0.2 mm thick.”	Change request #370

Location	Old	New	Reason
Section 2.1, Introduction	—	<p>IMPORTANT Most countries and regions restrict electromagnetic emissions across the frequency spectrum. Products have to comply with these regulations when they are sold for use in those countries and regions. Meeting the applicable requirements can be more or less difficult depending on the Power Transmitter design being used in the product. In some countries or regions, it can be economically unfeasible to use some of the Power Transmitter designs defined in this Part 4: Reference Designs.</p>	Change request #378
Section 2.2.2, Power Transmitter design A2	Power Transmitter design A1	Power Transmitter design A10	Change request #376

Location	Old	New	Reason
<p>Section 2.2.11.2, Electrical details</p>	<p>Power Transmitter design A11 uses the Operating Frequency... of power that is transferred. For this purpose, the Operating Frequency range of the full-bridge inverter is $f_{op} = 110 \dots 205$ kHz with a duty cycle of 50%; and its duty cycle range is 10...50% at an Operating Frequency of 205 kHz. A higher Operating Frequency or lower duty cycle result in the transfer of a lower amount of power. In order to achieve a sufficiently accurate adjustment...</p> <p>...</p> <p>When a type A11 Power Transmitter first applies a Power Signal...it shall use an initial Operating Frequency of 175 kHz (and a duty cycle of 50%).</p>	<p>Power Transmitter design A11 uses the Operating Frequency...of power that is transferred. For this purpose, the Operating Frequency range of the full-bridge inverter is $f_{op} = 110 \dots 205$ kHz. At frequencies below 145 kHz, its duty cycle is 50%, and at frequencies above 145 kHz its duty cycle range is in the range of 10%...50%. A higher Operating Frequency or lower duty cycle results in the transfer of a lower amount of power.</p> <p>NOTE In the operating frequency range of 145 kHz to 205 kHz, it is possible to use both the frequency and the duty cycle to control the power level. For example, in countries where operation at frequencies above 148 kHz is not allowed, the Power Transmitter can use duty cycle control at a frequency of 148 kHz instead of 205 kHz.</p> <p>...</p> <p>When a type A11 Power Transmitter first applies a Power Signal...it shall use an initial Operating Frequency in the range of 145 kHz to 175 kHz (and a duty cycle of 50%).</p>	<p>Change request #399</p>

Location	Old	New	Reason
Section 2.2.28.2, Electrical details	<p>Power Transmitter design A28 uses the Operating Frequency... of power that is transferred. For this purpose, the Operating Frequency range of the full-bridge inverter is $f_{op} = 110 \dots 205$ kHz with a duty cycle of 50%; and its duty cycle range is 10...50% at an Operating Frequency of 205 kHz. A higher Operating Frequency or lower duty cycle result in the transfer of a lower amount of power. In order to achieve a sufficiently accurate adjustment...</p> <p>...</p> <p>When a type A28 Power Transmitter first applies a Power Signal...it shall use an initial Operating Frequency of 175 kHz (and a duty cycle of 50%).</p>	<p>Power Transmitter design A28 uses the Operating Frequency...of power that is transferred. For this purpose, the Operating Frequency range of the full-bridge inverter is $f_{op} = 110 \dots 205$ kHz. At frequencies below 145 kHz, its duty cycle is 50%, and at frequencies above 145 kHz its duty cycle range is in the range of 10%...50%. A higher Operating Frequency or lower duty cycle results in the transfer of a lower amount of power.</p> <p>NOTE In the operating frequency range of 145 kHz to 205 kHz, it is possible to use both the frequency and the duty cycle to control the power level. For example, in countries where operation at frequencies above 148 kHz is not allowed, the Power Transmitter can use duty cycle control at a frequency of 148 kHz instead of 205 kHz.</p> <p>...</p> <p>When a type A28 Power Transmitter first applies a Power Signal...it shall use an initial Operating Frequency in the range of 145 kHz to 175 kHz (and a duty cycle of 50%).</p>	Change request #399
Section 2.4.6, Power Transmitter design MP-A6	—	Power Transmitter design MP-A6	Change request #348
Section 2.4.6.1, Primary Coil	<p>Inner height: $19.0^{±1.0}$ mm Outer width: $48.0^{±1.0}$ mm Inner width: $19.0^{±1.0}$ mm</p>	<p>Inner height: $26.0^{±1.0}$ mm Outer width: $44.0^{±1.0}$ mm Inner width: $22.0^{±1.0}$ mm</p>	Change request #395

Location	Old	New	Reason
Section 2.4.7	—	Power Transmitter design MP-A7	Change request #384
Section 2.4.8, Power Transmitter design MP-A8	—	Power Transmitter design MP-A8	Change request #344
Section 2.4.9, Power Transmitter design MP-B1	—	Power Transmitter design MP-B1	Change request #363