

Counter Based Finite State Machines

Last updated 7/18/23

Counter Based FSMs

- Complex FSMs

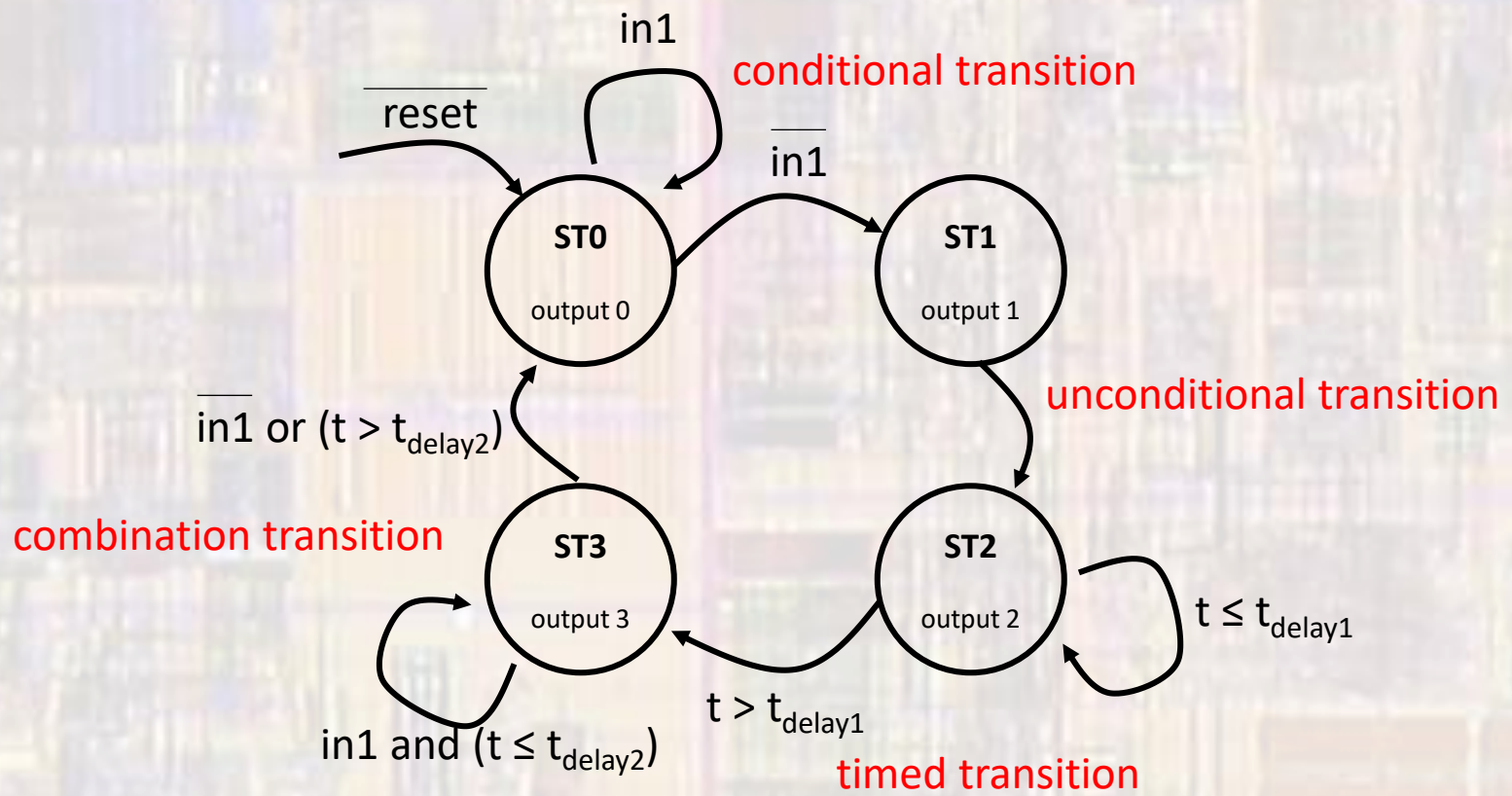

Counter Based FSMs

Timed FSMs

Counter Based FSMs

- Timed FSMs

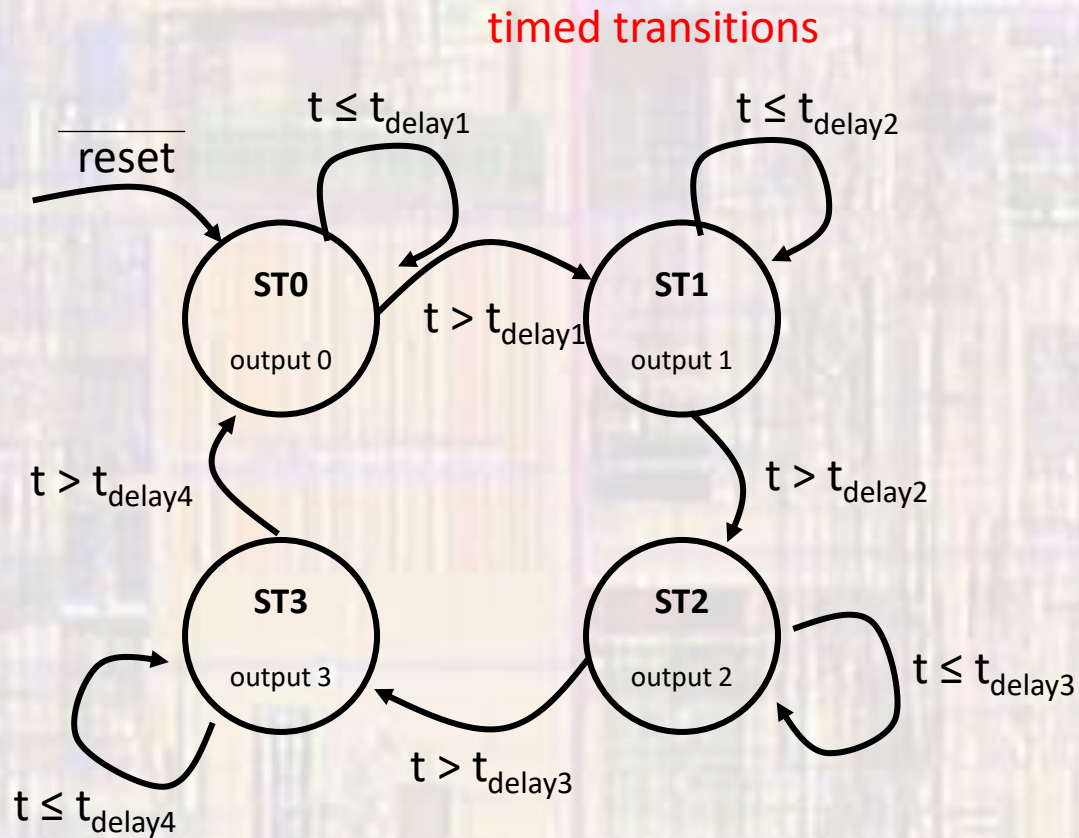

Counter Based FSMs

- Timed FSMs

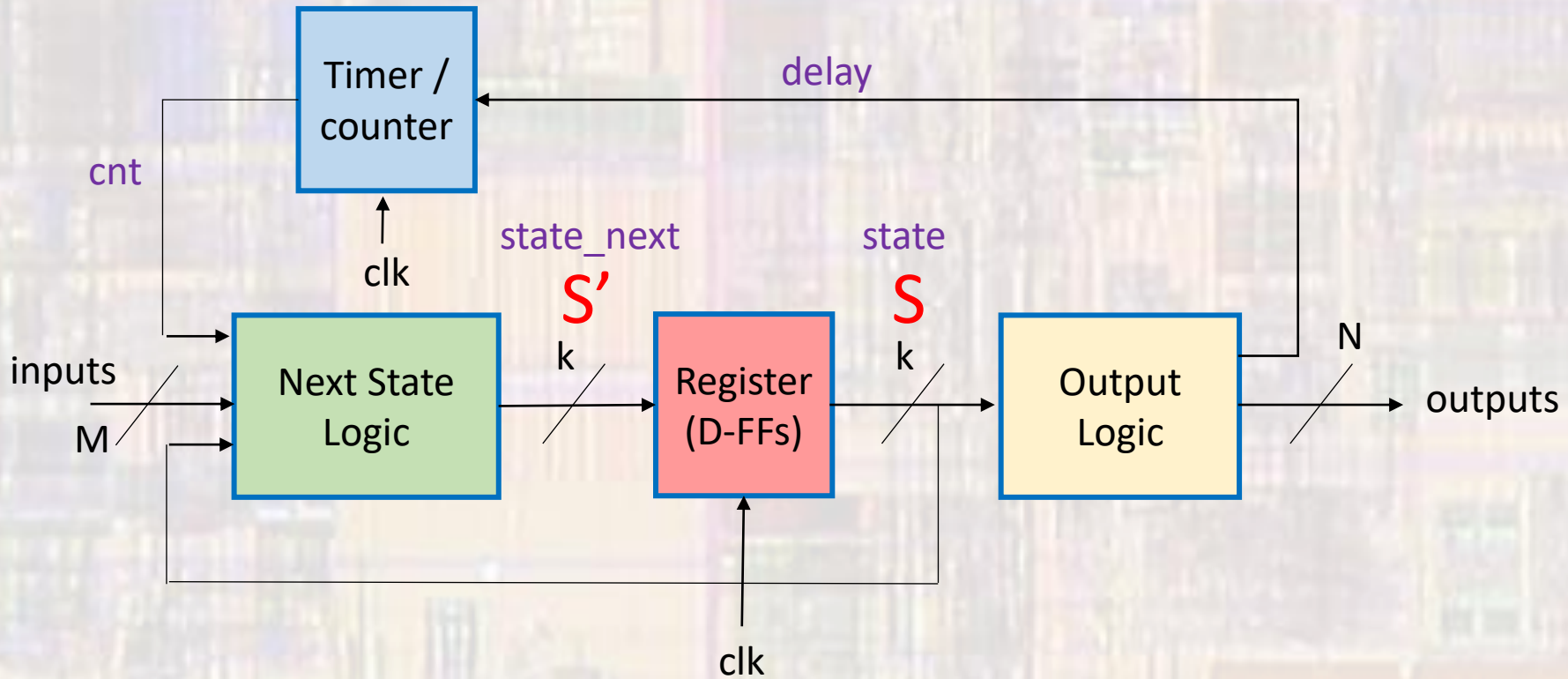

Counter Based FSMs

- Timed FSMs
 - Generalized approach
 - Use a timer (counter)
 - Timing based on clock cycles
 - Reset the timer when it reaches a pre-defined value
 - Check the timer before changing states

```
--  
-- Timer  
--  
process(i_clk, i_rstb)  
begin  
  -- reset  
  if (i_rstb = '0') then  
    cnt <= (others => '0');  
  -- rising clk edge  
  elsif (rising_edge(i_clk)) then  
    if(cnt < delay - 1) then  
      cnt <= cnt + 1;  
    else  
      cnt <= (others => '0');  
    end if;  
  end if;  
end process;
```

Separate from the state logic

Size of `cnt` and `delay` dependent on longest delay

`delay` set in the output logic
(state dependent)

Counter Based FSMs

- Timed FSMs – stoplight
 - 10sec GR
 - 1sec YR
 - 14 sec RG
 - 5 sec RY

Counter Based FSMs

- Timed FSMs – stoplight

```
-----
-- stoplight_timed_fsm.vhdl
-- created 3/30/18
-- tj
-- version 3
-- rev 0
-----
--
-- Timed Stoplight
-----|
--
-- Inputs: rstb, clk
-- Outputs: lightsA, lightsB
--          01->Green, 10->Yellow, 11->red
-----
library ieee;
use ieee.std_logic_1164.all;
use ieee.numeric_std.all;

entity stoplight_timed_fsm is
  generic(
    N:          natural := 5;          -- # of count bits
    T_GR:       unsigned := "01010"; -- delays
    T_YR:       unsigned := "00001";
    T_RG:       unsigned := to_unsigned(14, 5);
    T_RY:       unsigned := to_unsigned(5, 5)
  );
  port (
    i_clk :    in std_logic;
    i_rstb :   in std_logic;

    o_lights_A : out std_logic_vector(1 downto 0);
    o_lights_B : out std_logic_vector(1 downto 0)
  );
end entity;
```

```
architecture behavioral of stoplight_timed_fsm is
  --
  -- State Types
  --
  type STATE_TYPE is (GR, YR, RG, RY);
  signal state:      STATE_TYPE;
  signal state_next: STATE_TYPE;
  --
  -- Timer signals
  --
  signal cnt:        unsigned((N - 1) downto 0);
  signal delay:      unsigned((N - 1) downto 0);
  --
  -- Convenience Constants
  --
  constant green:    std_logic_vector := "01";
  constant yellow:   std_logic_vector := "10";
  constant red:      std_logic_vector := "11";
begin
```

Counter Based FSMs

- Timed FSMs – stoplight

```

-- Timer
--
process(i_clk, i_rstb)
begin
  -- reset
  if (i_rstb = '0') then
    cnt <= (others => '0');
  -- rising clk edge
  elsif (rising_edge(i_clk)) then
    if(cnt < delay - 1) then
      cnt <= cnt + 1;
    else
      cnt <= (others => '0');
    end if;
  end if;
end process;

```

```

-- next state logic
--
process(all)
begin
  case state is
    when GR =>
      if(cnt < T_GR - 1) then
        state_next <= GR;
      else
        state_next <= YR;
      end if;
    when YR =>
      if(cnt < T_YR - 1) then
        state_next <= YR;
      else
        state_next <= RG;
      end if;
    when RG =>
      if(cnt < T_RG - 1) then
        state_next <= RG;
      else
        state_next <= RY;
      end if;
    when others =>
      if(cnt < T_RY - 1) then
        state_next <= RY;
      else
        state_next <= GR;
      end if;
  end case;
end process;

```

```

-- Register logic
--
process(i_clk, i_rstb)
begin
  -- reset
  if (i_rstb = '0') then
    state <= GR;
  -- rising clk edge
  elsif (rising_edge(i_clk)) then
    state <= state_next;
  end if;
end process;

```

```

-- Output logic
--
process(all)
begin
  case state is
    when GR =>
      delay <= T_GR;
      o_lights_A <= green;
      o_lights_B <= red;
    when YR =>
      delay <= T_YR;
      o_lights_A <= yellow;
      o_lights_B <= red;
    when RG =>
      delay <= T_RG;
      o_lights_A <= red;
      o_lights_B <= green;
    when others =>
      delay <= T_RY;
      o_lights_A <= red;
      o_lights_B <= yellow;
  end case;
end process;
end behavioral;

```

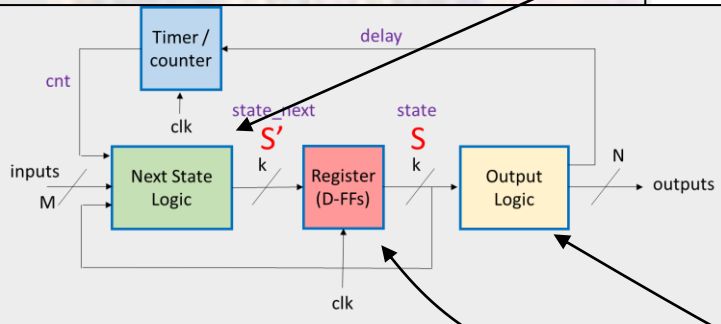

Counter Based FSMs

- Timed FSMs – stoplight

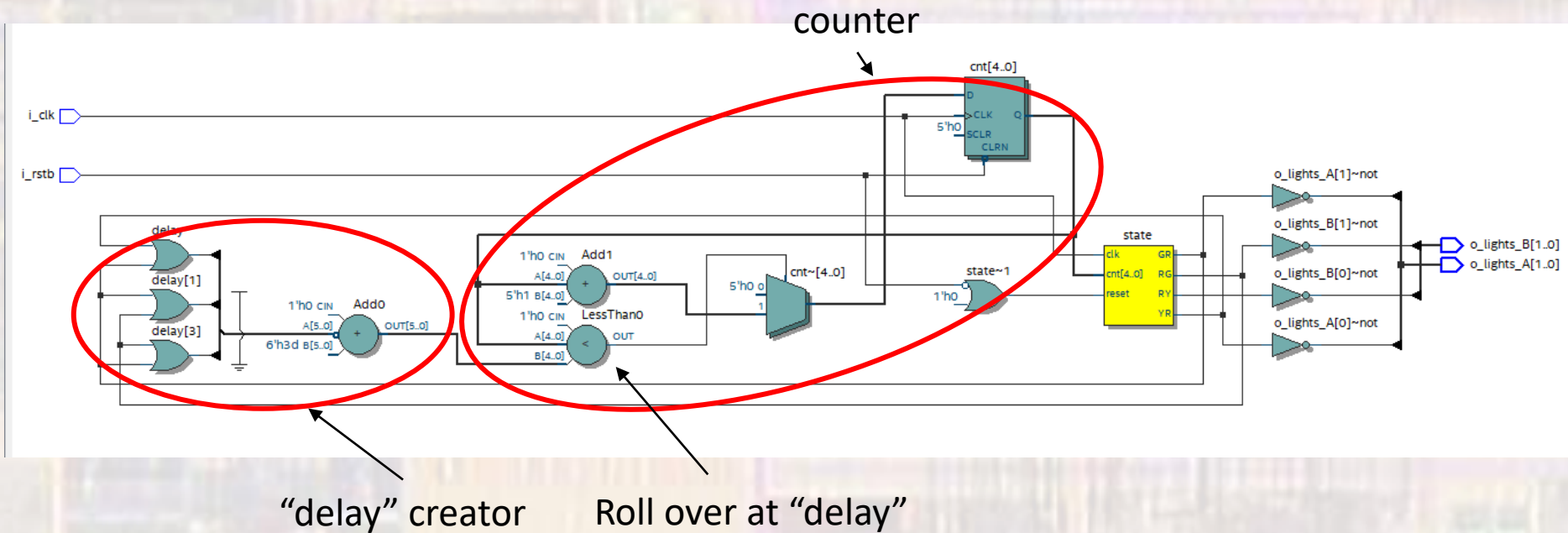

Counter Based FSMs

- Timed FSMs – stoplight

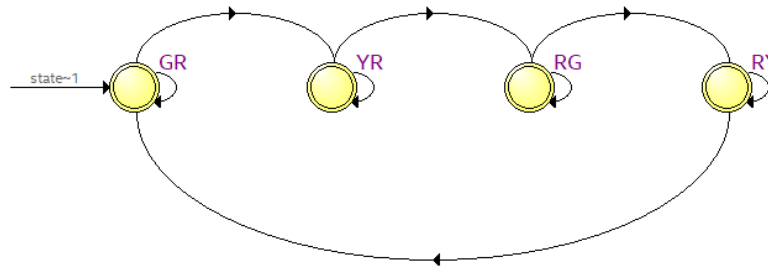

Source State	Destination State	Condition
1 GR	YR	$(!cnt[1]).(!cnt[2]).(cnt[4]) + (!cnt[1]).(cnt[2]).(!cnt[3]).(cnt[4]) + (!cnt[1]).(cnt[2]).(cnt[3]) + (cnt[1]).(!cnt[3]).(cnt[4]) + (cnt[1]).(cnt[3]).(!cnt[4])$
2 GR	GR	$(!cnt[1]).(!cnt[2]).(!cnt[4]) + (!cnt[1]).(cnt[2]).(!cnt[3]).(!cnt[4]) + (cnt[1]).(!cnt[3]).(!cnt[4])$
3 RG	RY	$(!cnt[1]).(cnt[4]) + (cnt[1]).(!cnt[2]).(cnt[4]) + (cnt[1]).(cnt[2]).(!cnt[3]).(cnt[4]) + (cnt[1]).(cnt[2]).(cnt[3])$
4 RG	RG	$(!cnt[1]).(!cnt[4]) + (cnt[1]).(!cnt[2]).(!cnt[4]) + (cnt[1]).(cnt[2]).(!cnt[3]).(!cnt[4])$
5 RY	RY	$(!cnt[0]).(!cnt[1]).(!cnt[3]).(!cnt[4]) + (!cnt[0]).(cnt[1]).(!cnt[2]).(!cnt[3]).(!cnt[4]) + (cnt[0]).(!cnt[2]).(!cnt[3]).(!cnt[4])$
6 RY	GR	$(!cnt[0]).(!cnt[1]).(!cnt[3]).(cnt[4]) + (!cnt[0]).(!cnt[1]).(cnt[3]) + (!cnt[0]).(cnt[1]).(!cnt[2]).(!cnt[3]).(cnt[4]) + (!cnt[0]).(cnt[1]).(!cnt[2]).(cnt[3])$
7 YR	YR	$(!cnt[0]).(!cnt[1]).(!cnt[2]).(!cnt[3]).(!cnt[4])$
8 YR	RG	$(!cnt[0]).(!cnt[1]).(!cnt[2]).(!cnt[3]).(cnt[4]) + (!cnt[0]).(!cnt[1]).(!cnt[2]).(cnt[3]) + (!cnt[0]).(!cnt[1]).(cnt[2]) + (!cnt[0]).(cnt[1]) + (cnt[0]).(!cnt[2]).(cnt[3])$

Counter Based FSMs

- Timed FSMs – stoplight

```
T_GR: unsigned := "01010";  
T_YR: unsigned := "00001";  
T_RG: unsigned := to_unsigned(14, 5);  
T_RY: unsigned := to_unsigned(5, 5);
```

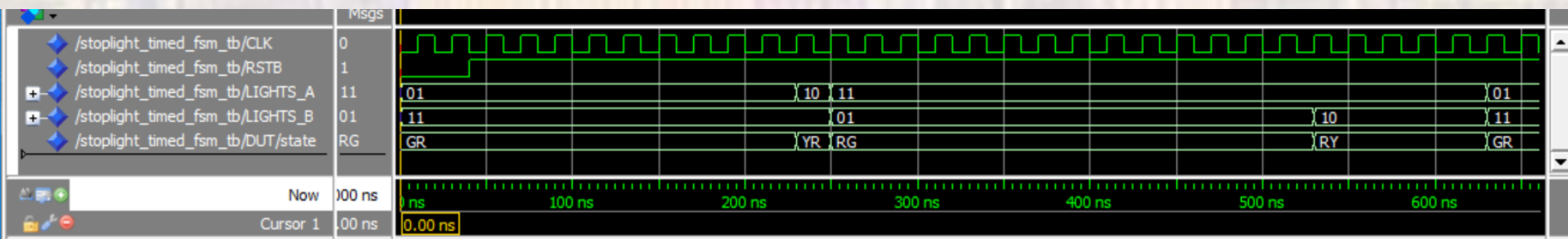

Counter Based FSMs

- Generalized counting FSMs

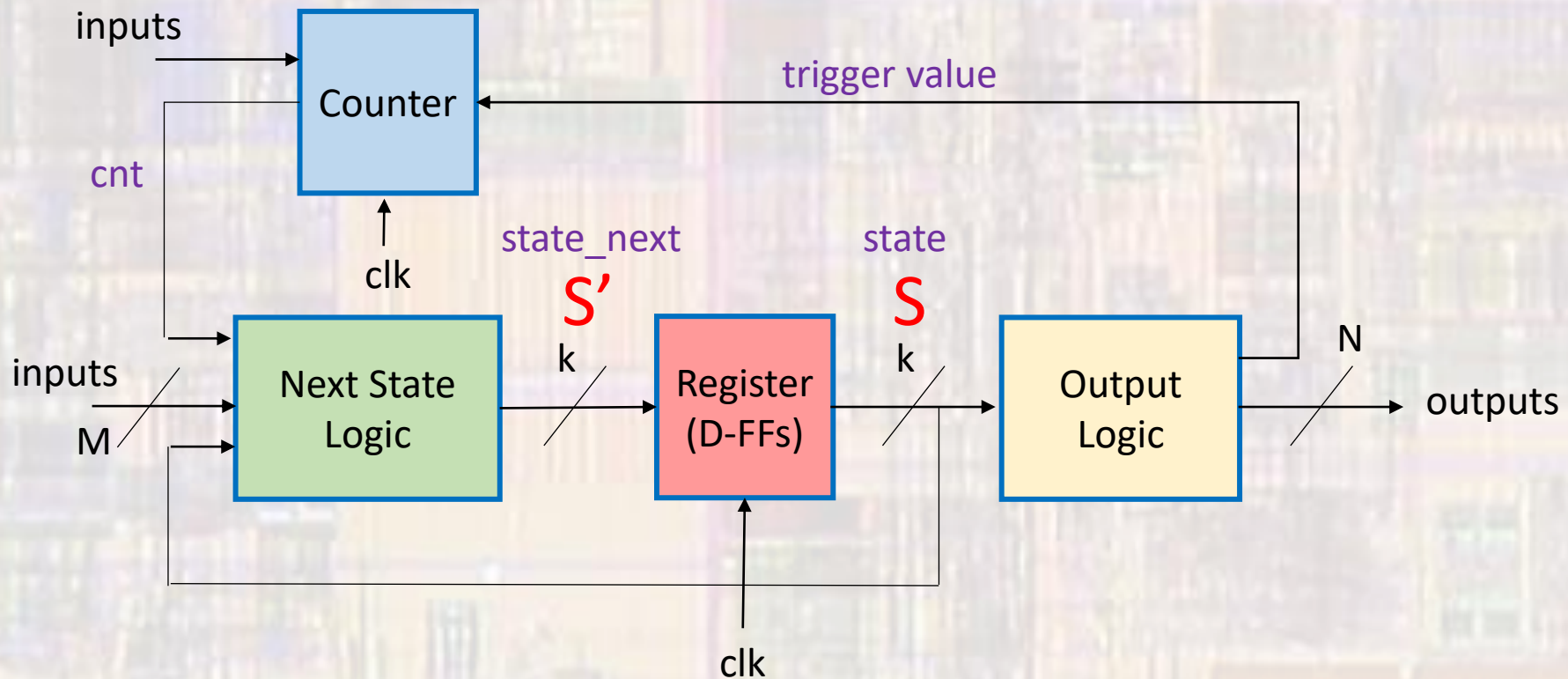

Counter Based FSMs

- Toll booth – terrible version

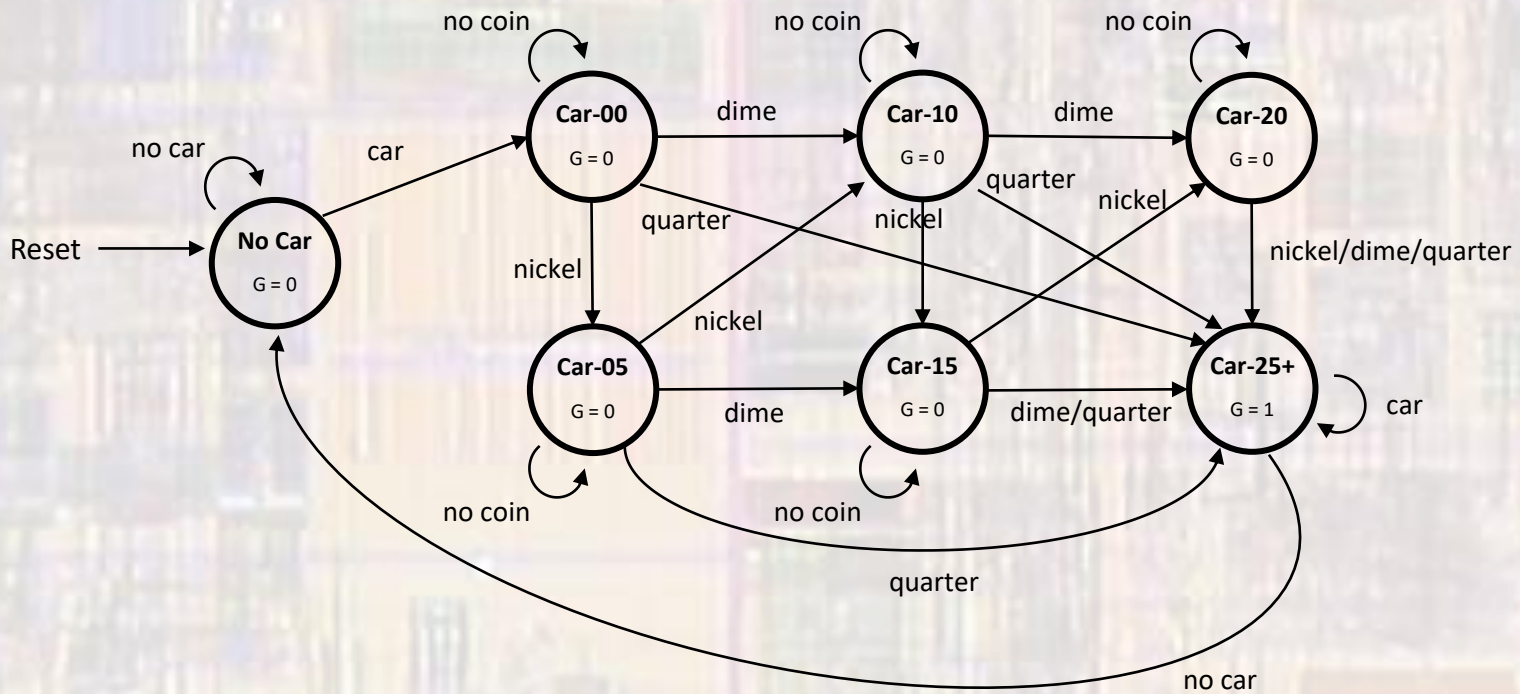

Counter Based FSMs

- Toll booth
 - Optimal solution

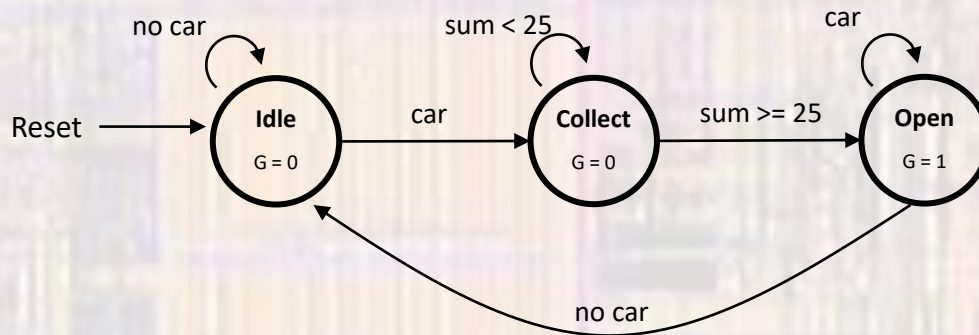

Counter Based FSMs

- Toll booth

```
-----  
-- toll_booth_fsm.vhd1  
--  
-- created 4/9/18  
-- tj  
--  
-- rev 0  
-----  
--  
-- toll booth FSM example  
--  
-- cash handled entirely in register  
-----  
--  
-- Inputs: rstb, clk, N, D, Q, car  
-- Outputs: gate  
-----  
library ieee;  
use ieee.std_logic_1164.all;  
use ieee.numeric_std.all;  
  
entity tollbooth_fsm is  
  port (  
    i_clk      : in std_logic;  
    i_rstb     : in std_logic;  
    i_N        : in std_logic;  
    i_D        : in std_logic;  
    i_Q        : in std_logic;  
    i_car      : in std_logic;  
  
    o_gate     : out std_logic  
  );  
end entity;
```

```
architecture behavioral of tollbooth_fsm is  
  --  
  -- State Types  
  --  
  type STATE_TYPE is (Idle, Collect, Gate_open);  
  signal state:      STATE_TYPE;  
  signal state_next: STATE_TYPE;  
  --  
  -- Counter signals  
  --  
  signal cash:      unsigned(7 downto 0);  
  
begin
```

Counter Based FSMs

- Toll booth

```

--
-- cash counter
process(i_clk, i_rstb)
begin
-- reset
if (i_rstb = '0') then
cash <= (others => '0');
-- rising clk edge
elsif (rising_edge(i_clk)) then
if (i_N = '1') then
cash <= cash + 5;
elsif (i_D = '1') then
cash <= cash + 10;
elsif (i_Q = '1') then
cash <= cash + 25;
elsif (state = Idle) then
cash <= (others => '0');
else
cash <= cash;
end if;
end if;
end process;

```

```

--
-- next state logic
process(all)
begin
case state is
when Idle=>
if(i_car = '1') then
state_next <= Collect;
else
state_next <= state;
end if;
when Collect =>
if(cash >= 25) then
state_next <= Gate_open;
else
state_next <= state;
end if;
when Gate_open =>
if(i_car = '0') then
state_next <= Idle;
else
state_next <= state;
end if;
when others =>
state_next <= Idle;
end case;
end process;

```

```

--
-- Register logic
process(i_clk, i_rstb)
begin
-- reset
if (i_rstb = '0') then
state <= Idle;
-- rising clk edge
elsif (rising_edge(i_clk)) then
state <= state_next;
end if;
end process;

```

```

--
-- Output logic
process(all)
begin
case state is
when Idle =>
o_gate <= '0';
when Collect =>
o_gate <= '0';
when Gate_open =>
o_gate <= '1';
when others =>
o_gate <= '0';
end case;
end process;
end behavioral;

```

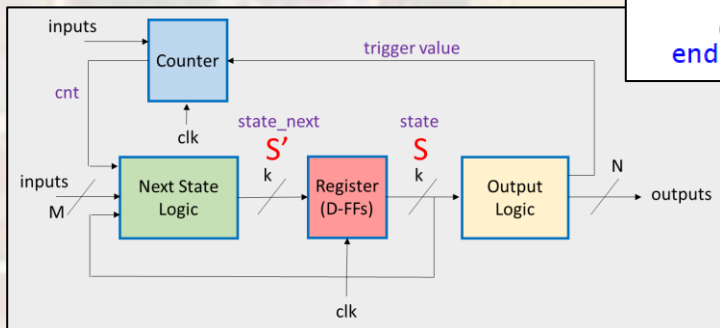

Counter Based FSMs

- Toll booth

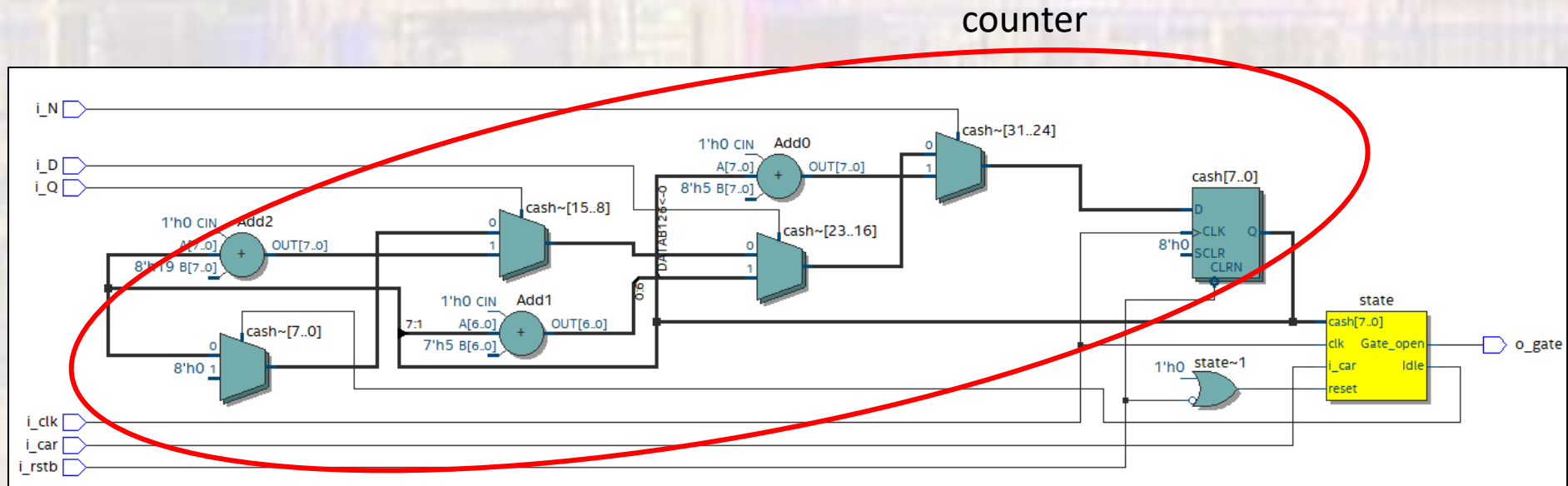

Counter Based FSMs

- Toll booth

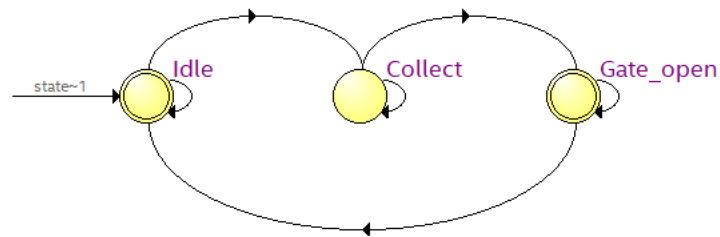

	Source State	Destination State	
1	Collect	Gate_open	(!cash[0]),(!cash[1]),(!cash[2]),(!cash[5]),(!cash[6]),(cash[7]) + (!cash[0]),(!cash[1]),(!cash[2]),(!cash[5]),(cash[6]) + (!cash[0]),(!cash[1]),(!cash[2]),(!cash[5]),(!cash[6]),(cash[7])
2	Collect	Collect	(!cash[0]),(!cash[1]),(!cash[2]),(!cash[5]),(!cash[6]),(!cash[7]) + (!cash[0]),(!cash[1]),(cash[2]),(!cash[3]),(!cash[5]),(!cash[6]),(!cash[7])
3	Gate_open	Idle	(i_car)
4	Gate_open	Gate_open	(i_car)
5	Idle	Idle	(i_car)
6	Idle	Collect	(i_car)

Counter Based FSMs

- Toll Booth

