

ROM

Last updated 9/19/23

Memory - ROM

- ROM – Read Only Memory
 - Memory cell (1 bit) is based on whether a MOSFET is or is not connected between the bit line and word line
 - The MOSFET structure is always part of the bit cell
 - It can be connected to the bit line through a contact or via (via ROM)
 - It can be disabled by removing the S/D diffusion (diffusion ROM)
 - Cannot be modified once the part is built
 - Typically used as Boot memory or to hold chip configuration data

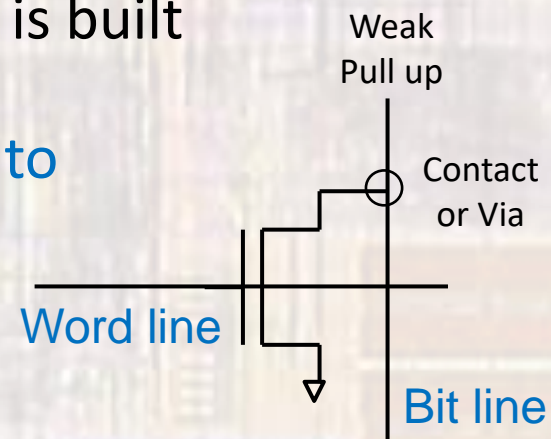

Memory - ROM

- ROM – Read Only Memory

- Read

- All Word lines low
- Read Enable (RE) high

- Strobe the desired word line high

- Sense amplifiers read the value of the bit lines

If connected – will read a “0”

If not connected – will read a “1”

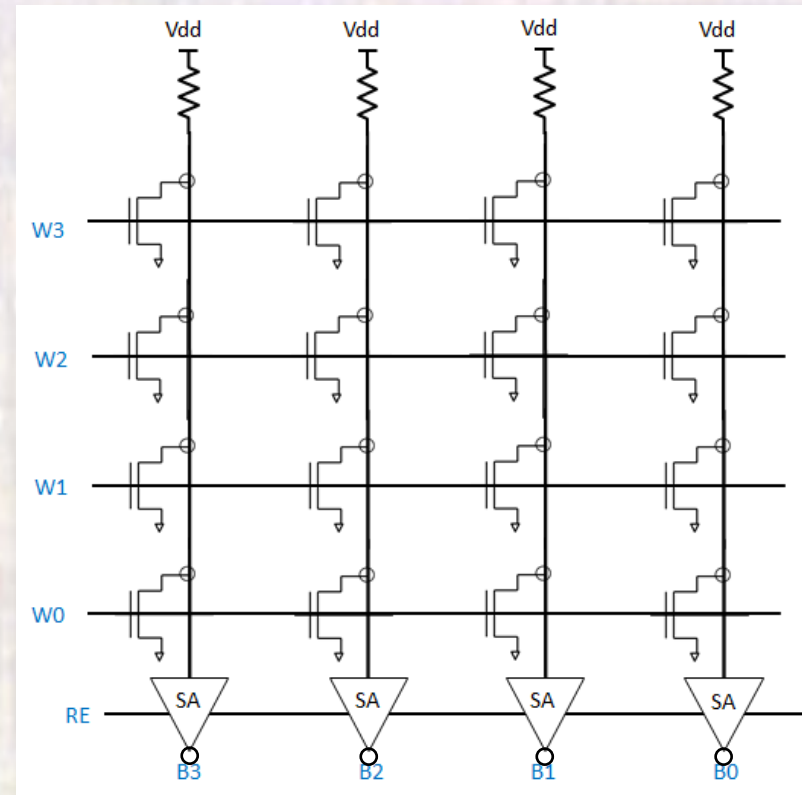
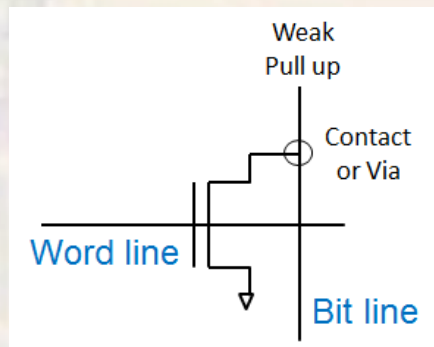

Memory - ROM

- ROM – Read Only Memory – Diffusion ROM

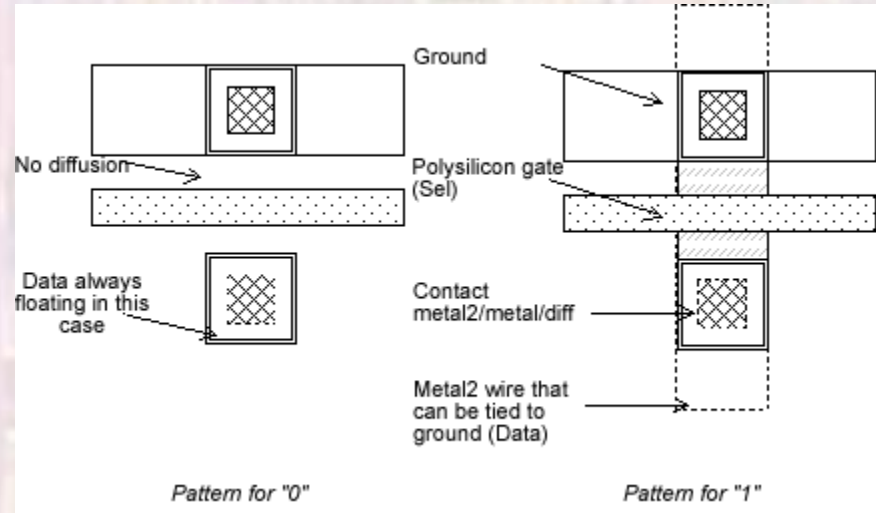
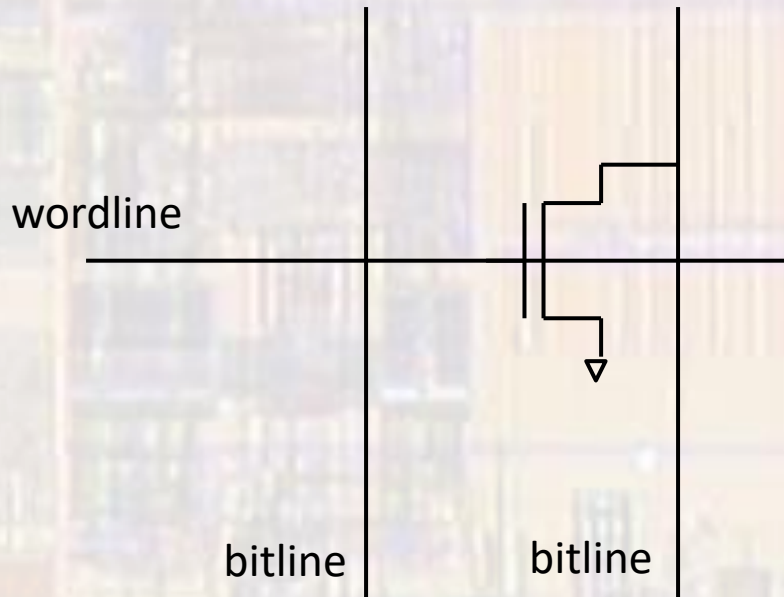

Memory - ROM

- ROM – Read Only Memory – Via (contact) ROM

