

MOS Circuit Characteristics

Last updated 12/22/23

MOS Enhancement Mode Transistor

- Planer Structure

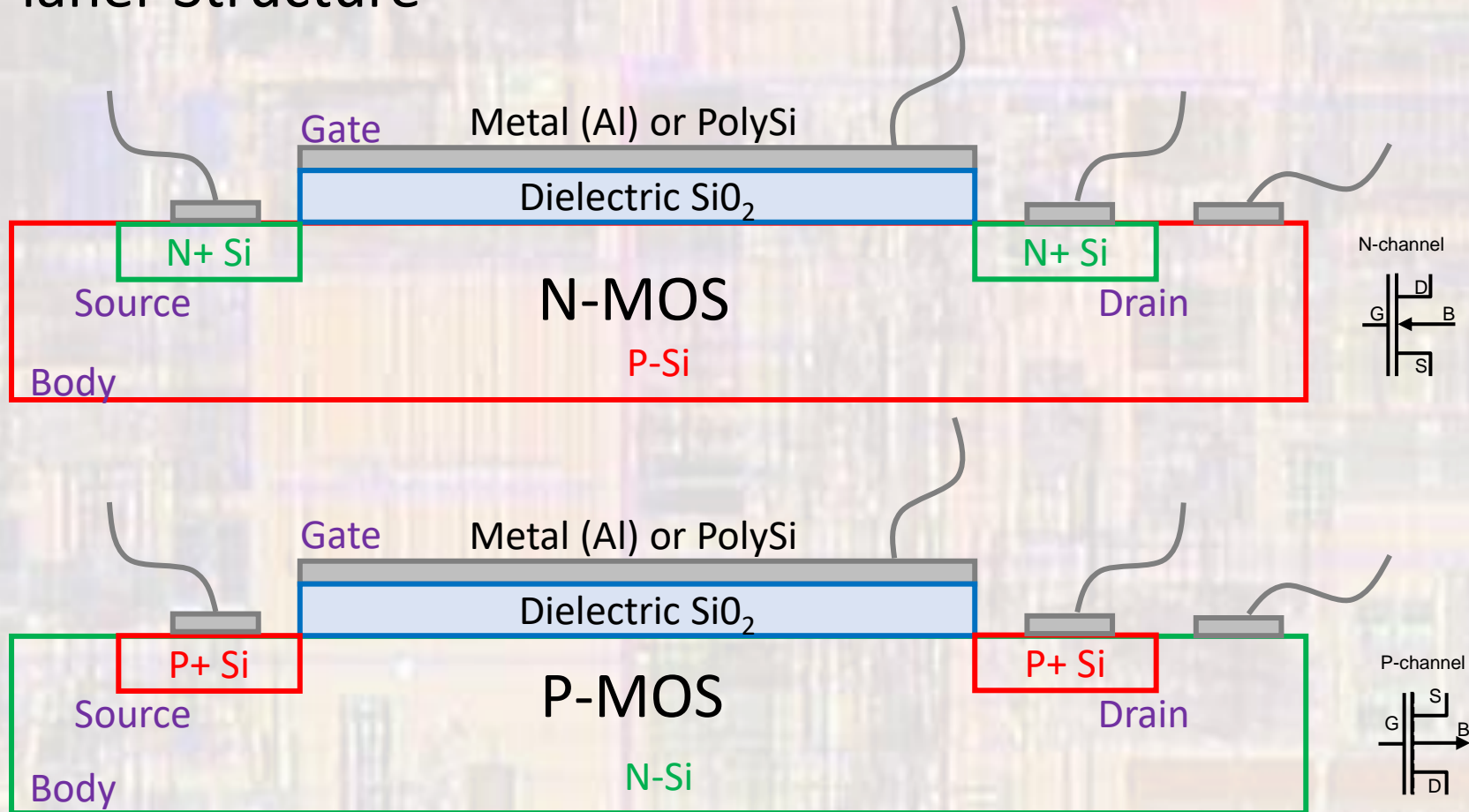

MOS Enhancement Mode Transistor

- Parasitic Elements

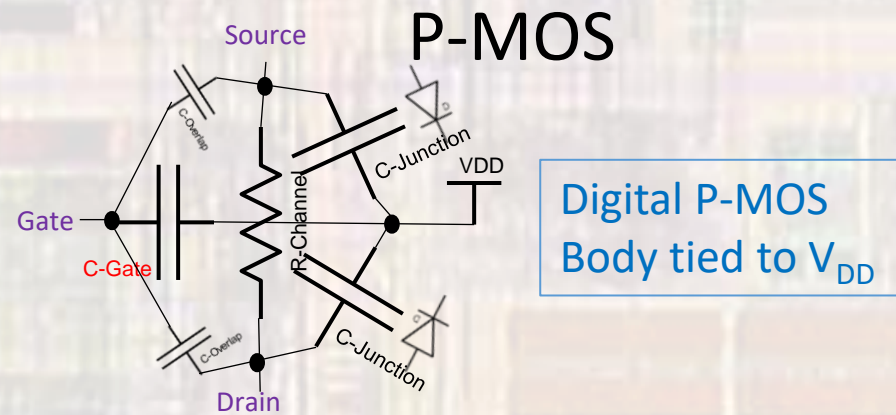
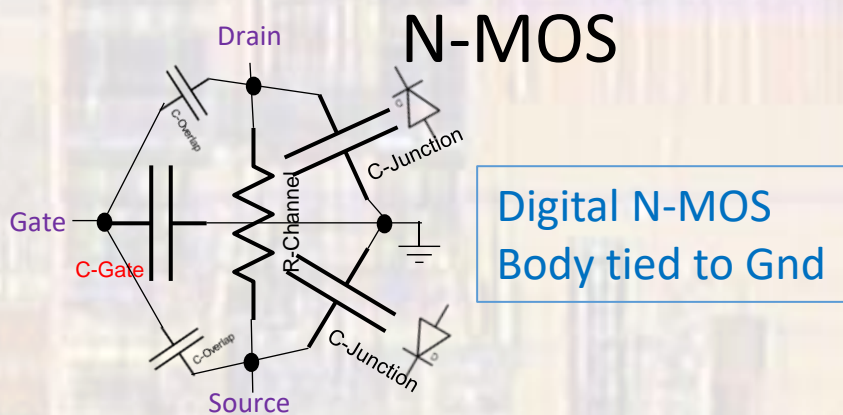
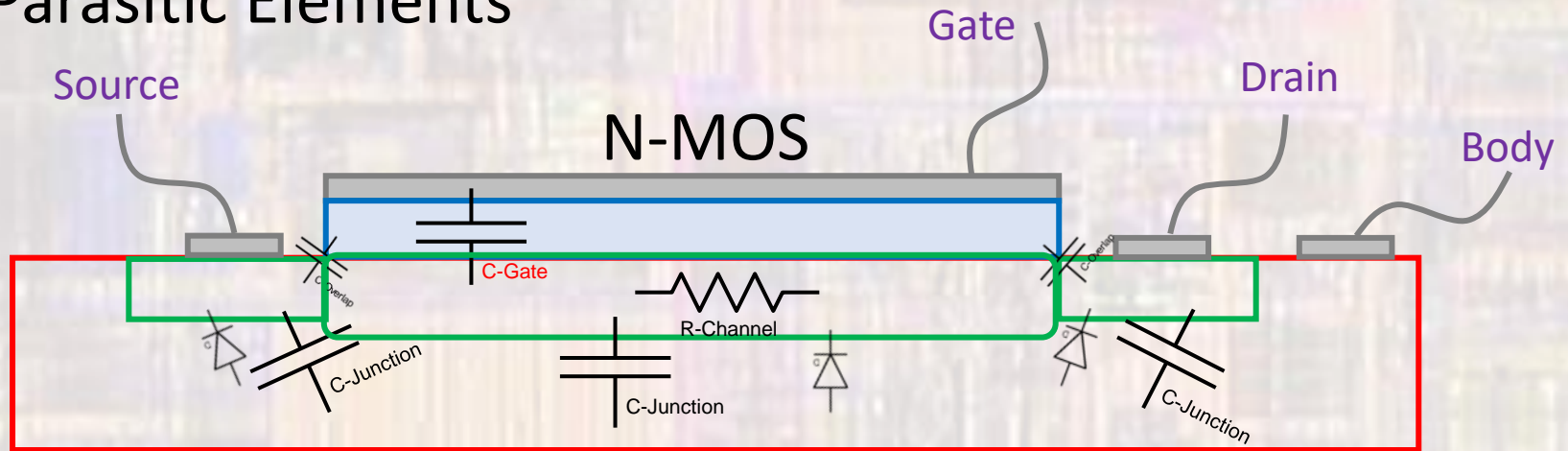

MOS Enhancement Mode Transistor

- Parasitic Elements
 - Gate
 - Capacitive
 - No DC current
 - AC/Transient current
 - S/D
 - Channel – Resistive
 - Dependent on V_{GS} and V_{DS}
 - Capacitive to Gnd (V_{DD})
 - No DC current
 - AC/Transient current
 - Reverse Biased Diode to Gnd (V_{DD})
 - Small leakage current independent of transistor action

MOS Enhancement Mode Transistor

- MOSFET Digital Configuration – body connections

- P-MOS body tied to V_{DD}



- N-MOS body tied to Gnd

