

Parallel Communications

PCIe

Last updated – 2/29/24

Parallel Communications - PCIe

- Intel – History

- North Bridge
- South Bridge

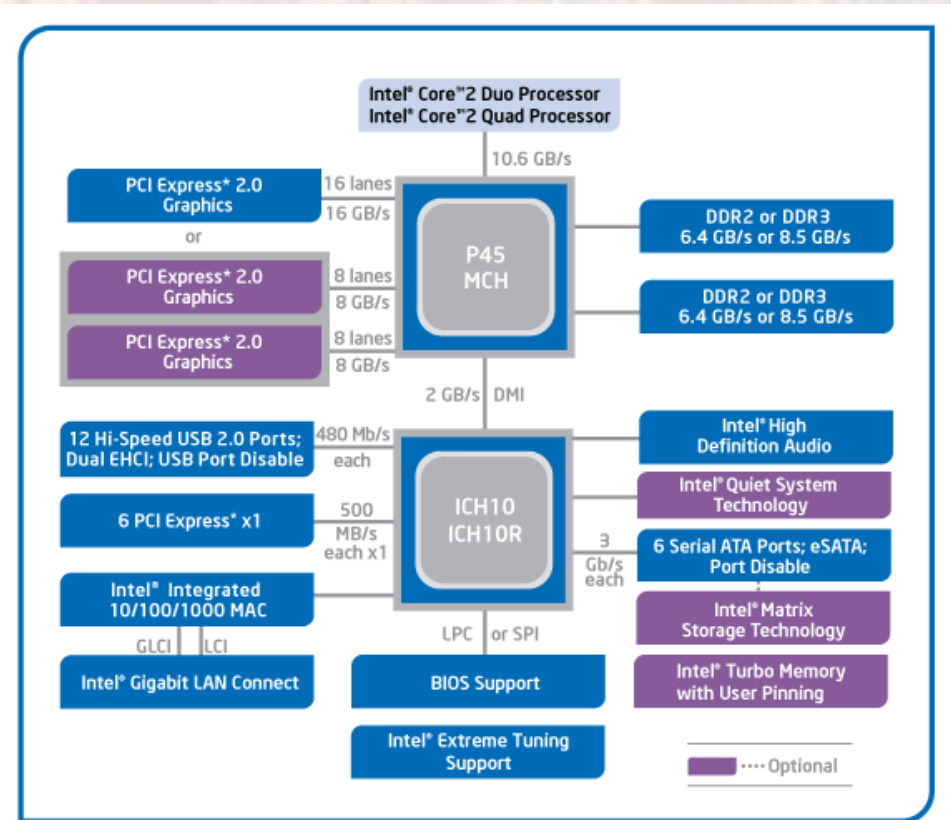

Intel® P45 Express Chipset Block Diagram

Parallel Communications - PCIe

- Intel – History

- “Chipset”

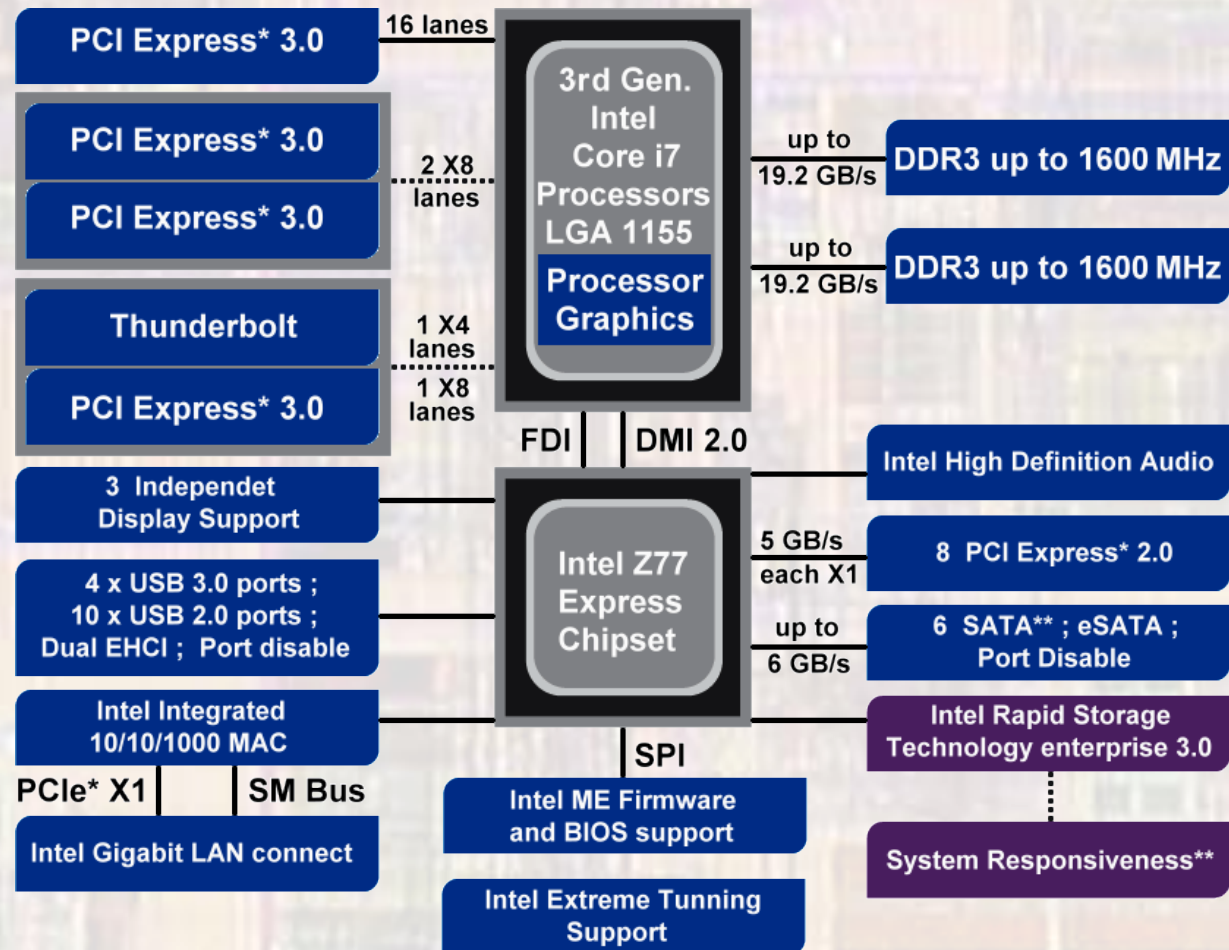

* Other Names and Brands may be claimed as property of others.
 ** Includes Intel Smart Response Technology, Intel Rapid Start Technology, and Intel Smart Connect Technology.

..... Optional

Parallel Communications - PCIe

- Intel – History
 - Ultra Path Interconnect
 - Coherent Snoop Architecture

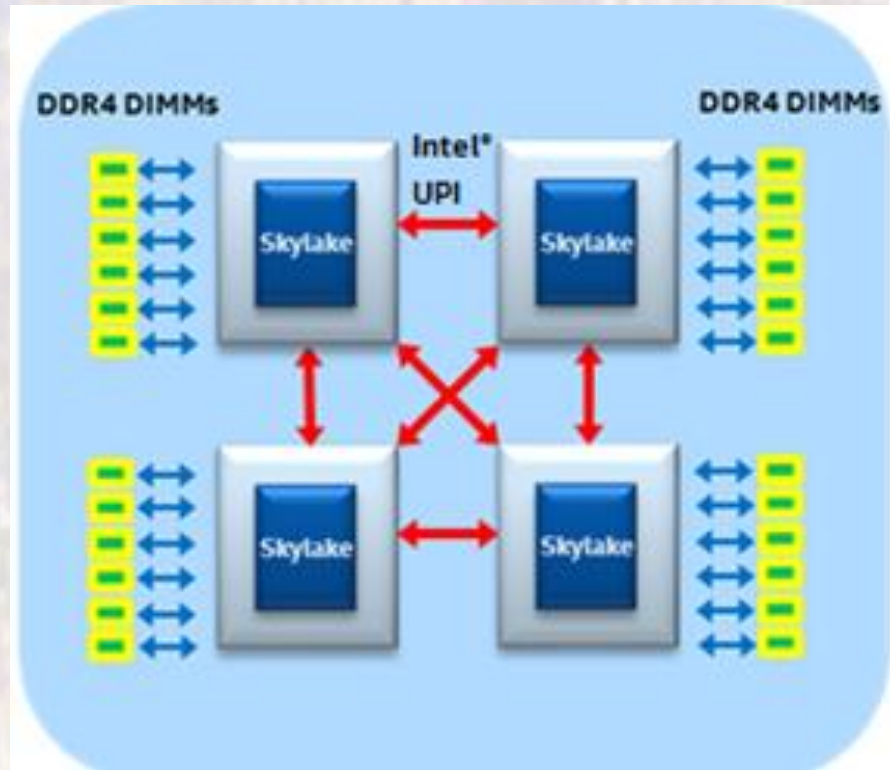

Parallel Communications - PCIe

- Overview
 - Peripheral Component Interconnect - Express
 - Preceded by PCI and PCI-X
 - But completely different physically
 - Logical configuration separate from the physical configuration
 - Logical configuration is backward compatible → SW reuse
 - On-chip or on-board
 - Packet based – point to point architecture

Parallel Communications - PCIe

- Link Structure
 - Point to point
 - Fixed – hardwired direct connection (**LINK**)
 - Full Duplex
 - Asynchronous outgoing vs. incoming

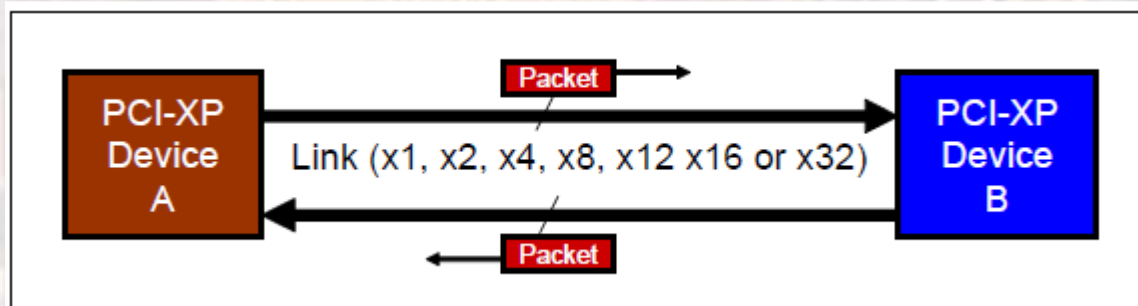

Parallel Communications - PCIe

- Link Structure
 - Why point to point?
 - Reduces the RC delay on the signals
 - Allows for very fast transfer speeds
 - 2.5GT/s, 5GT/s, 8GT/s, 16GT/s, 32GT/s with 64GT/s in 2021
 - GT/s – Giga-Transfers per second
 - Assumes simultaneous Rx/Tx

Parallel Communications - PCIe

- Networked - uses switches to route messages

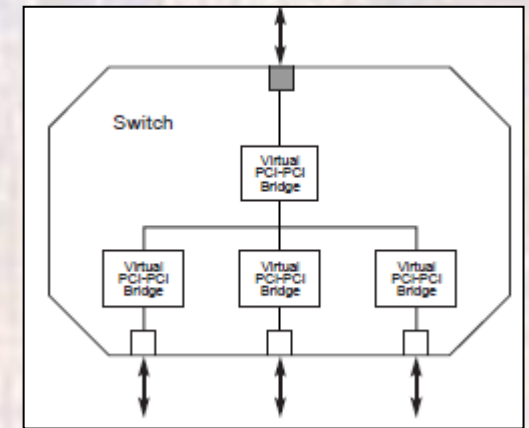
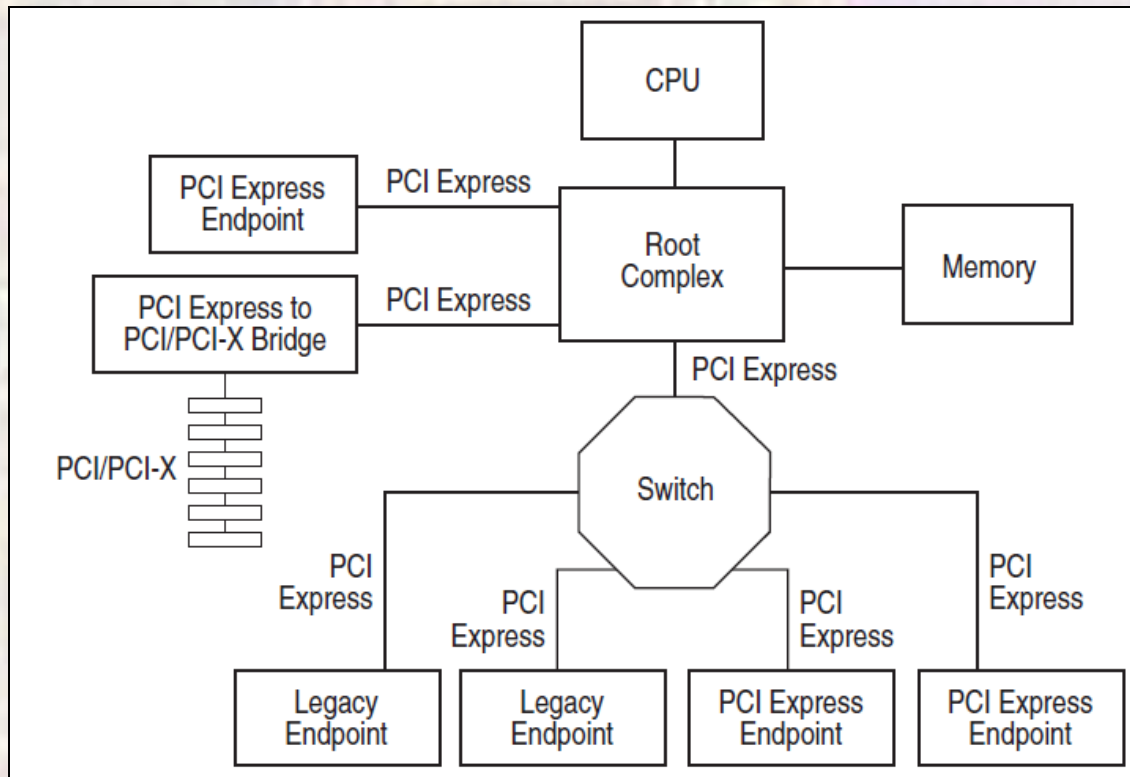

Parallel Communications - PCIe

- Link Structure
 - Lane
 - 1 transmit path and 1 receive path
 - Differential signaling → 4 wires/Lane
 - Link
 - Collection of Lanes
 - 1x, 2x, 4x, 8x, 12x, 16x, 32x
 - Symmetric – same both directions
 - **No Clock !**

Parallel Communications - PCIe

- Encoding
 - PCIe 1.x and 2.x use 8b/10b encoding
 - PCIe 3.x - 6.x use 128b/130b encoding
- 8b/10b Encoding
 - Maps 8 bit symbols to 10 bit symbols
 - Coding ensures # of 1s and # of 0s differ by ≤ 2 for any string of 20 bits
 - Coding ensures no more than 5, 0s or 1s in a row
 - Provides enough transitions to do clock recovery
 - Provides for DC balance

Parallel Communications - PCIe

- Lanes and Links

PCI Express version	Introduced	Line code	Transfer rate ^[1]	Throughput ^[1]				
				x1	x2	x4	x8	x16
1.0	2003	8b/10b	2.5 GT/s	250 MB/s	0.500 GB/s	1.00 GB/s	2.0 GB/s	4.0 GB/s
2.0	2007	8b/10b	5.0 GT/s	500 MB/s	1.000 GB/s	2.00 GB/s	4.0 GB/s	8.0 GB/s
3.0	2010	128b/130b	8.0 GT/s	984.6 MB/s	1.969 GB/s	3.94 GB/s	7.88 GB/s	15.75 GB/s
4.0	2017	128b/130b	16.0 GT/s	1969 MB/s	3.938 GB/s	7.88 GB/s	15.75 GB/s	31.51 GB/s
5.0	2019	128b/130b	32.0 GT/s ^[1]	3938 MB/s	7.877 GB/s	15.75 GB/s	31.51 GB/s	63.02 GB/s
6.0 (planned)	2021	128b/130b	64.0 GT/s	7877 MB/s	15.754 GB/s	31.51 GB/s	63.02 GB/s	126.03 GB/s

But wait !

$5\text{GT/s} \times 8 \text{ links} = 40\text{GT/s}$

$40\text{GT/s} / 8 \text{ bits} = 5\text{GB/s}$

Why the difference?

Parallel Communications - PCIe

- Signaling
 - Clock Recovery
 - Both Rx and Tx generate a common clock frequency
 - 2.5GHz, 5GHz, 8GHz, 16GHz
 - Only at the Rx/Tx interfaces
 - Phase between Rx and Tx is uncorrelated
 - Rx side uses a PLL to phase align the receiver clock to the incoming differential signal
 - This is where encoding helps – ensures sufficient transitions to keep PLL locked

Parallel Communications - PCIe

- Signaling

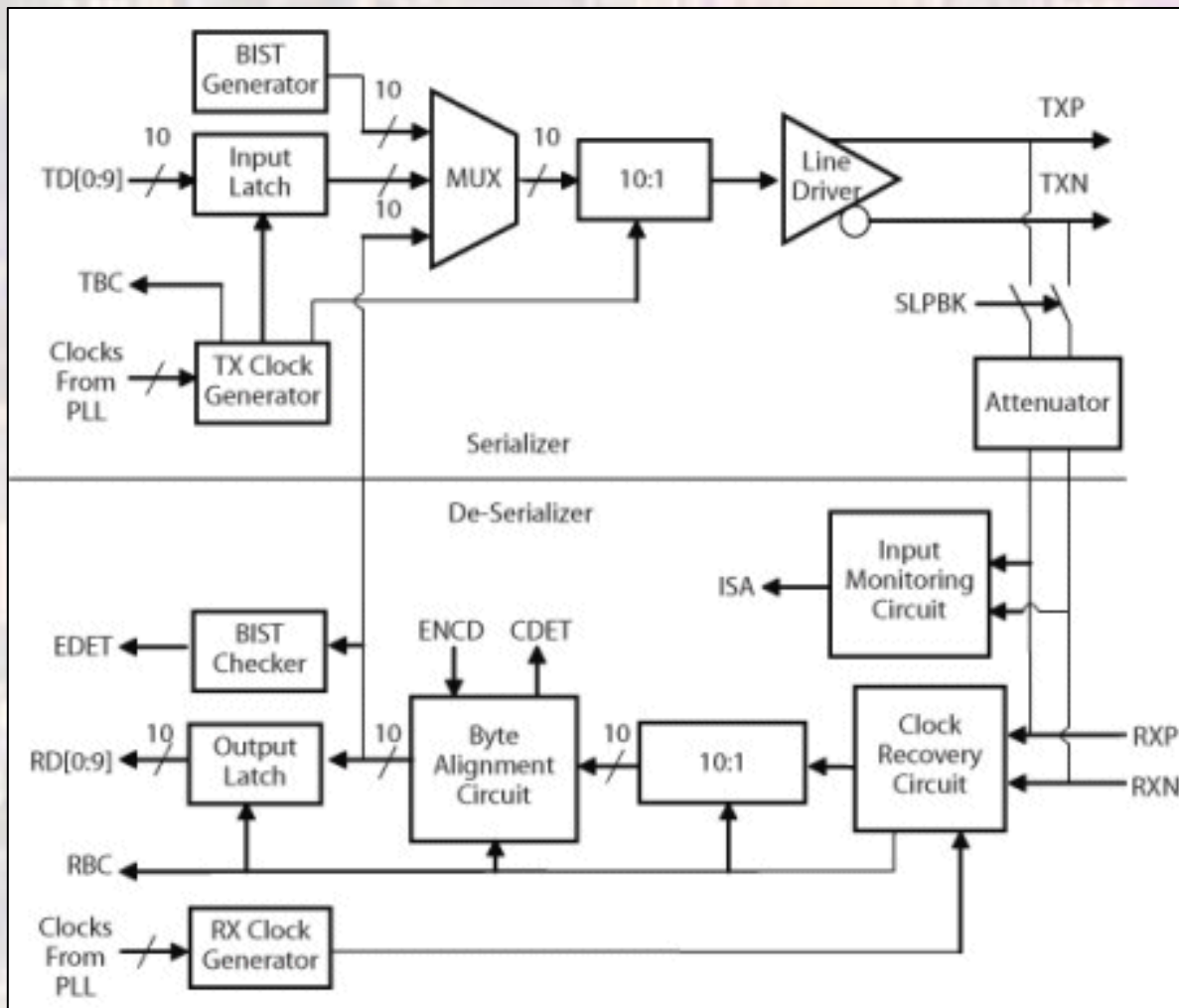

src: design reuse

Parallel Communications - PCIe

- Layering

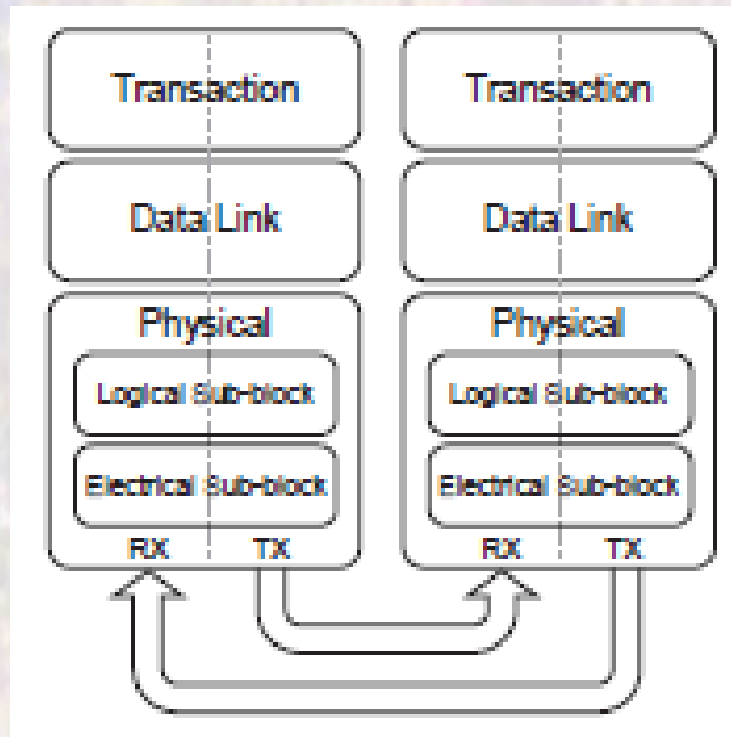

Parallel Communications - PCIe

- Packets

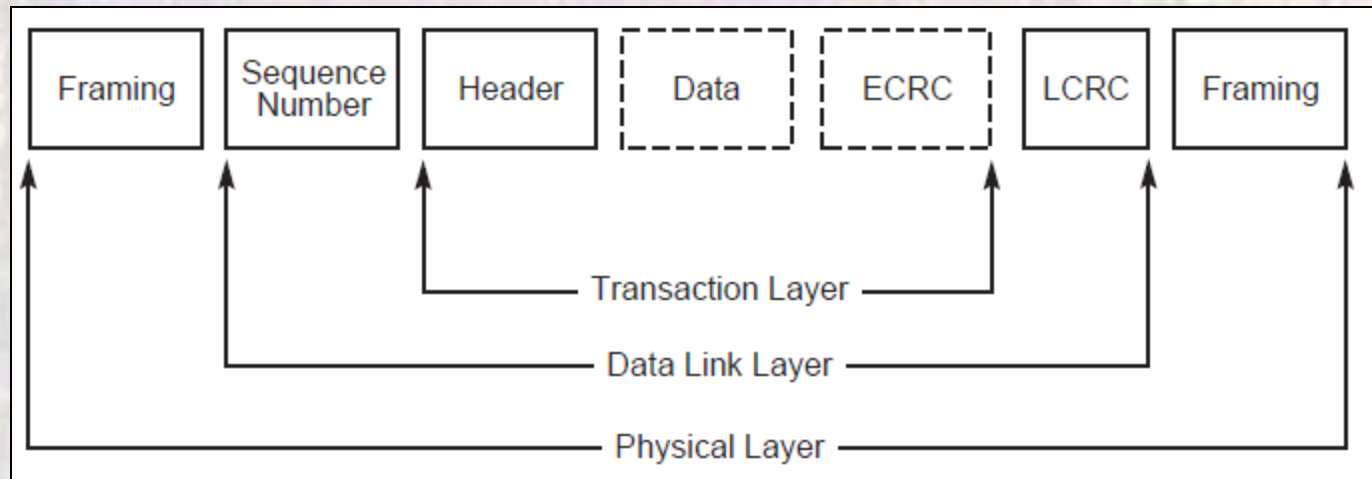

Parallel Communications - PCIe

- Primary Functional Blocks

- Root Complex
- Endpoint
- Switch
- Bridge

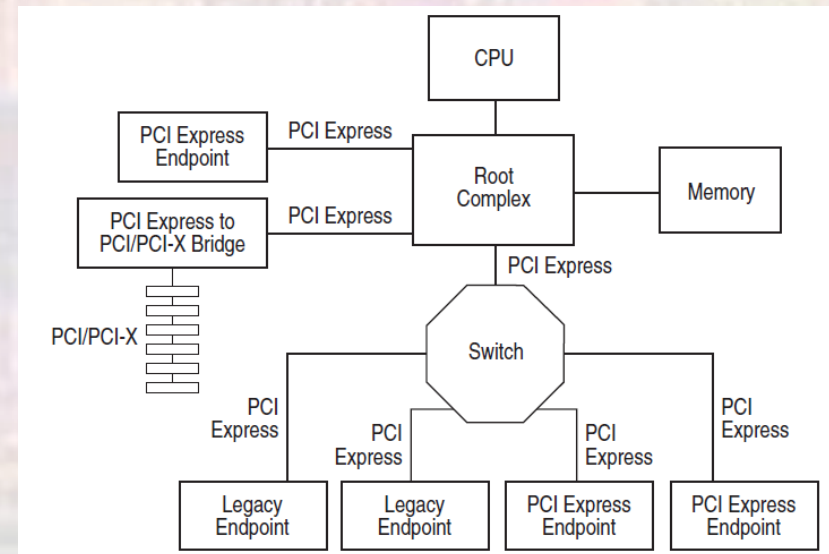

- Upstream Port (only 1) - points toward the root complex
- Downstream Port(s) – point away from root complex
- Ingress Port – incoming port (receiver)
- Egress Port – outgoing port (transmitter)

Parallel Communications - PC

- Root Complex

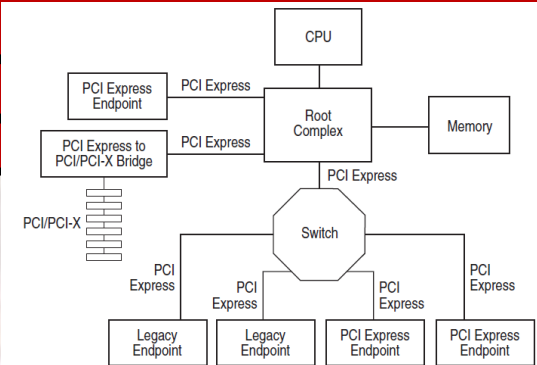

- Connects CPU(s) and Memory to the PCI fabric
- Multiple PCIe ports
- Generates transactions based on commands from the CPU
- Can act as power controller, interrupt controller, error detection response

Parallel Communications - PCIe

- Endpoint
 - Peripheral or bridge to another protocol
 - An endpoint can support multiple different functions

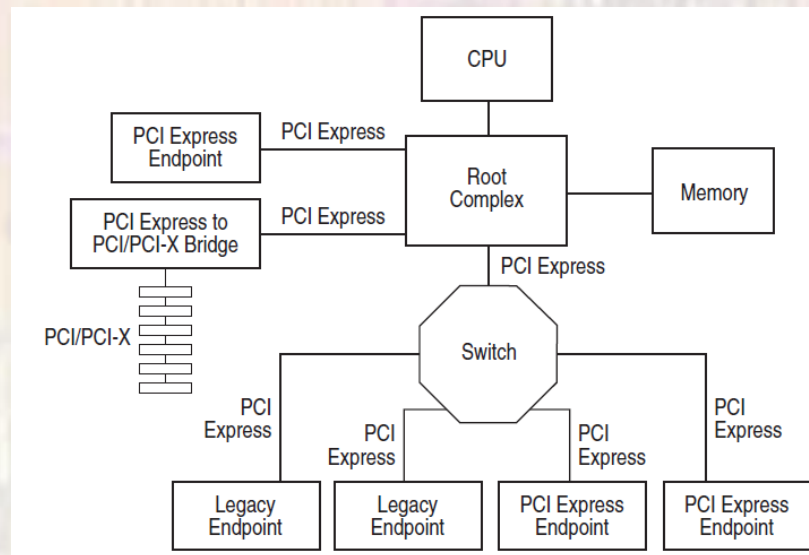

Parallel Communications - PCIe

- Switch
 - Acts like multiple virtual bridges – PCIe to PCIe
 - Hierarchy of bridges allowed
 - Configuration includes information on
 - Downstream devices
 - Downstream buses
 - Forwards based on
 - Address routing
 - ID routing
 - Implicit routing
 - Up one level, root device, ...

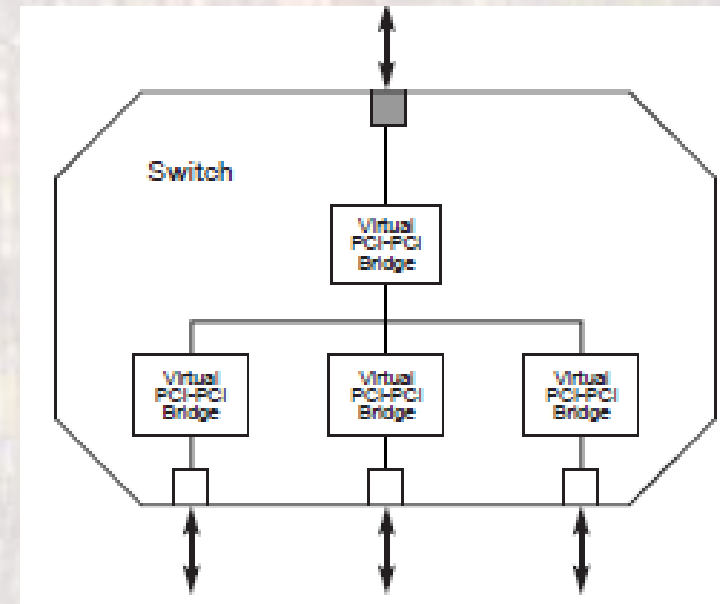

Parallel Communications - PCIe

- Switch – cont'd
 - Perform port arbitration
 - Multiple transactions to the same port
 - Perform Virtual Channel arbitration
 - Priority decisions

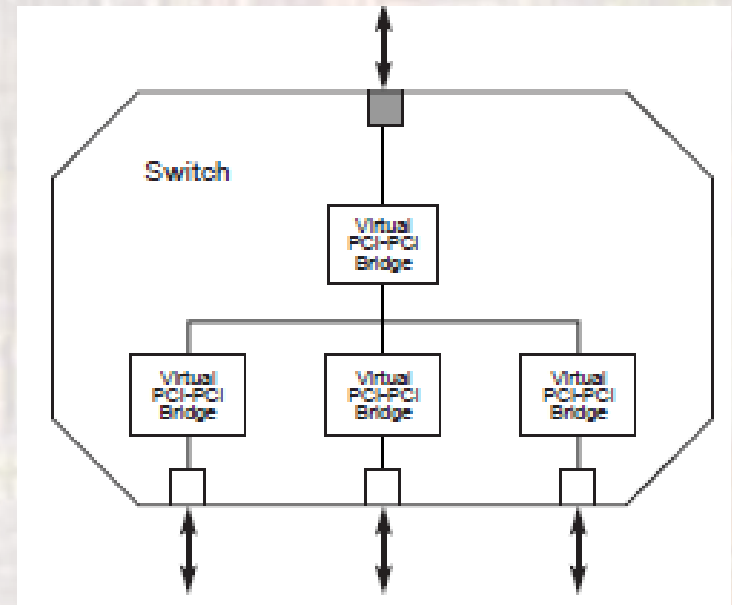

Parallel Communications - PCIe

- Elements
 - Each element has a device ID
 - Bus #
 - Device #
 - Function #
 - Root: 0,0,0 (b,d,f)
 - Endpoint: x,0,x
 - Each endpoint is defined as Device # 0
 - Multifunction endpoints must have a Function # 0

Parallel Communications - PCIe

- Transactions
 - Transaction
 - 1 or more packet transmissions
 - Each transaction has a Tag associated with it
 - Allows split transactions

Address Space	Transaction Types	Basic Usage
Memory	Read Write	Transfer data to/from a memory-mapped location
I/O	Read Write	Transfer data to/from an I/O-mapped location
Configuration	Read Write	Device Function configuration/setup
Message	Baseline (including Vendor-defined)	From event signaling mechanism to general purpose messaging

Parallel Communications - PCIe

- Transactions
 - Non-posted transaction
 - A response is expected at some future time
 - E.g. memory read
 - Posted transaction
 - No response is required or expected
 - E.g. non-posted memory write
- Requesters and Completers instead of Master/slave

Parallel Communications - PCIe

- Multi-Layer Protocol

- Transaction Layer
- Data Layer
- Physical Layer

- TLP

- Transaction Layer Packet
- Originates/terminates at the Transaction Layer

- DLLP

- Data Link Layer Packet
- Originates/terminates at the Data Link Layer

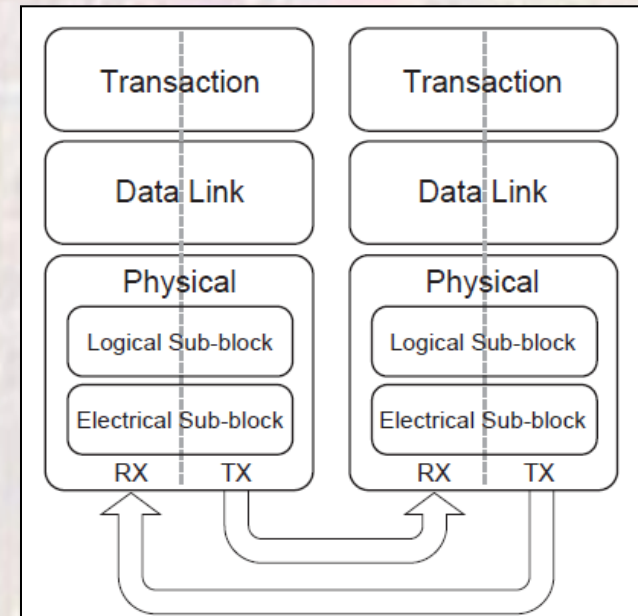

Parallel Communications - PCIe

- Multi-Layer Protocol

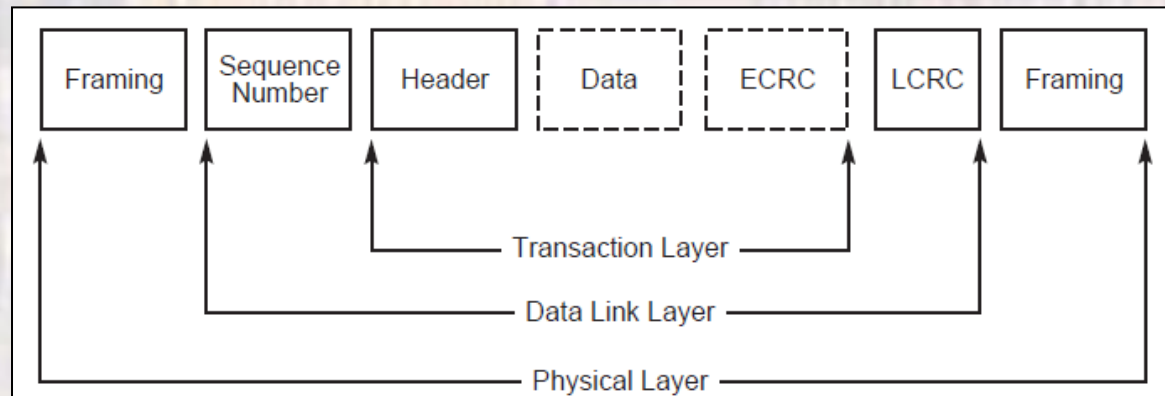
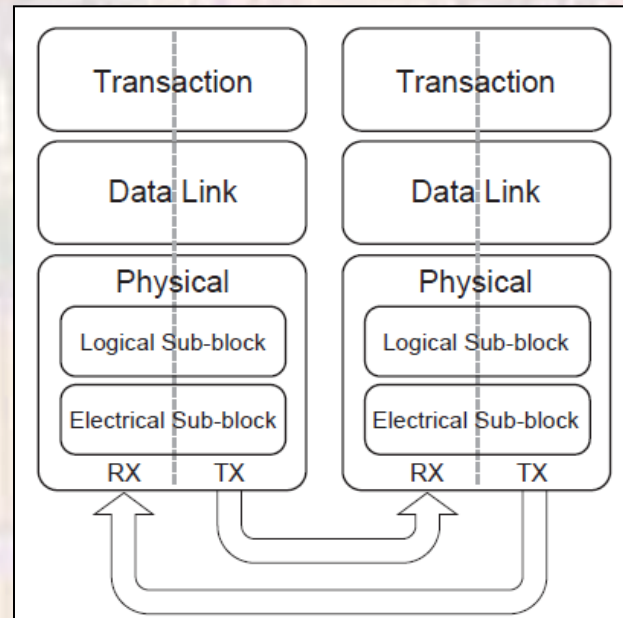

Parallel Communications - PCIe

- Transaction Layer
 - Creates TLPs
 - Interfaces to the peripheral to make requests or provide results
 - Read – address, device, ...
 - Write – address, device, data
 - Flow control
 - Buffer overflow, underflow
 - Each packet has a unique identifier
 - Where the Memory, IO, Config and Messages are created and consumed

Parallel Communications - PCIe

- Data Link Layer
 - Takes packet info from the Transaction Layer, adds to it, and transmits to the Physical Layer – and reverse
 - Provides Link Management
 - Supports data integrity
 - Error detection & correction
 - Requests re-transmits
 - Creates and uses packets for link management separate from transferring Transaction Layer information (DLLPs)

Parallel Communications - PCIe

- Physical Layer
 - Separated into two sections
 - Logical
 - Formats data
 - Adds framing information
 - Electrical
 - RX/TX circuitry

Parallel Communications - PCIe

- Transaction Layer Packets
- Left most bit transferred first

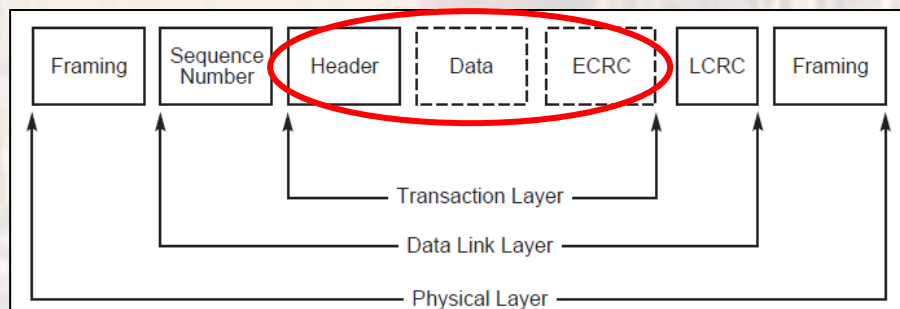
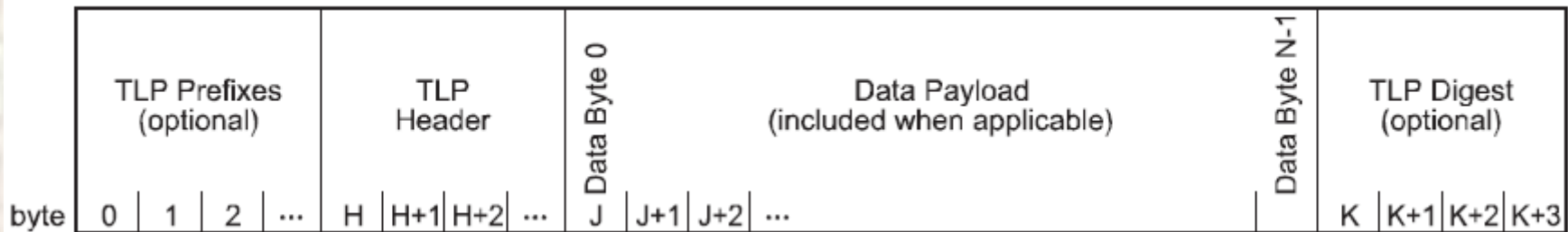

Parallel Communications - PCIe

- Transaction Layer Packets
- Left most bit transferred first

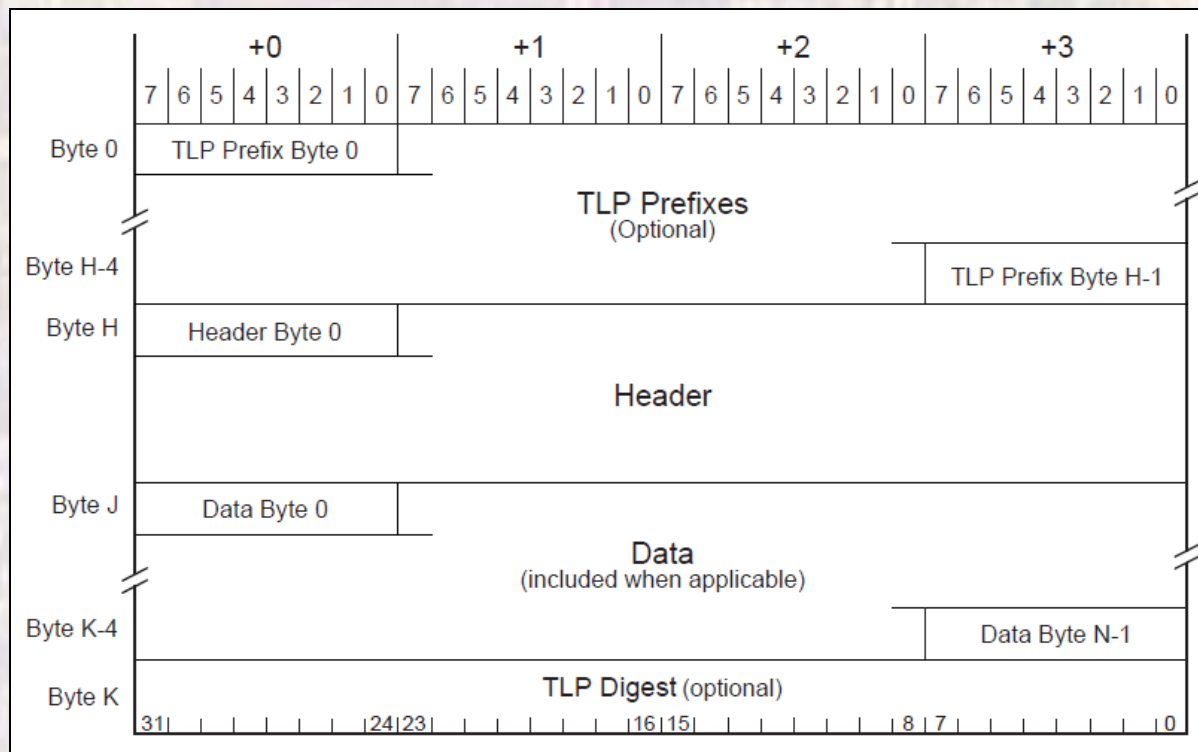

Parallel Communications - PCIe

- Transaction Layer Packets
- Header portion

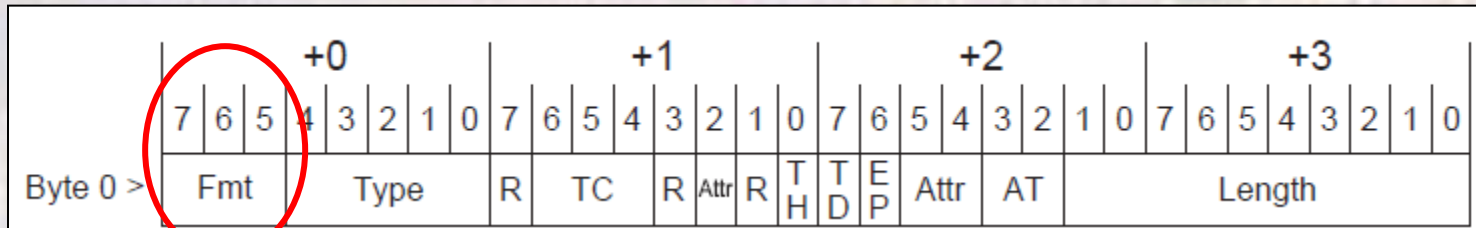

Fmt[2:0]	Corresponding TLP Format
000b	3 DW header, no data
001b	4 DW header, no data
010b	3 DW header, with data
011b	4 DW header, with data
100b	TLP Prefix

Parallel Communications - PCIe

- Transaction Layer Packets
 - Header portion

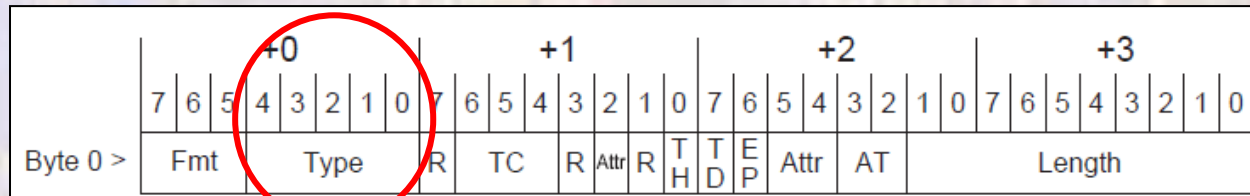

TLP Type	Fmt [2:0] ² (b)	Type [4:0] (b)	Description
MRd	000 001	0 0000	Memory Read Request
MRdLk	000 001	0 0001	Memory Read Request-Locked
MWr	010 011	0 0000	Memory Write Request
IORd	000	0 0010	I/O Read Request
IOWr	010	0 0010	I/O Write Request
CfgRd0	000	0 0100	Configuration Read Type 0
CfgWr0	010	0 0100	Configuration Write Type 0
CfgRd1	000	0 0101	Configuration Read Type 1
CfgWr1	010	0 0101	Configuration Write Type 1

Parallel Communications - PCIe

- Transaction Layer Packets
- Header portion

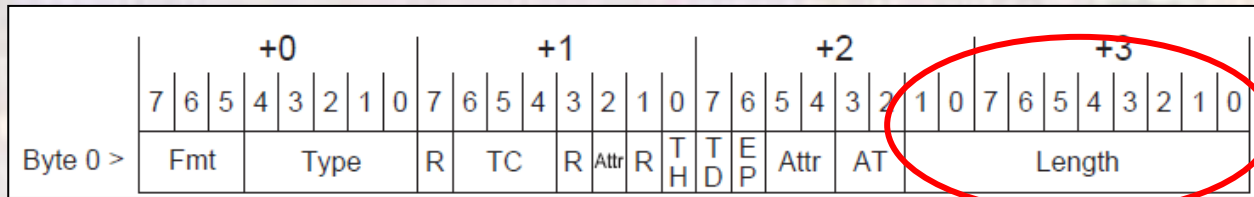

Length[9:0]	Corresponding TLP Data Payload Size
00 0000 0001b	1 DW
00 0000 0010b	2 DW
...	...
11 1111 1111b	1023 DW
00 0000 0000b	1024 DW

Parallel Communications - PCIe

- Transaction Layer Packets
 - Address Based Routing
 - 4 DW header
 - 64 bit addressing

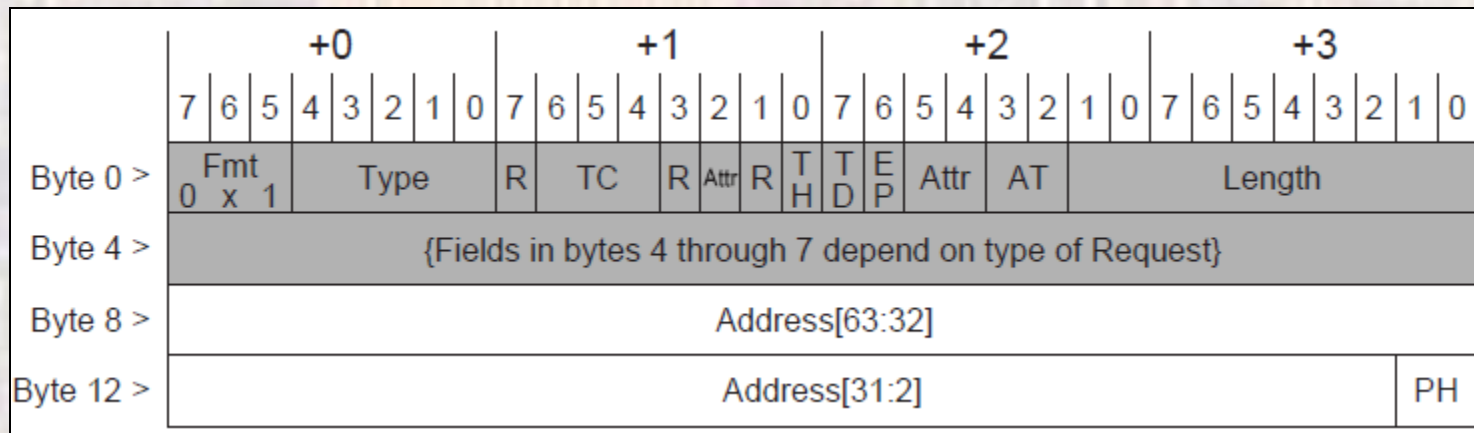

Parallel Communications - PCIe

- Transaction Layer Packets
 - Address Based Routing
 - 3 DW header
 - 32 bit addressing

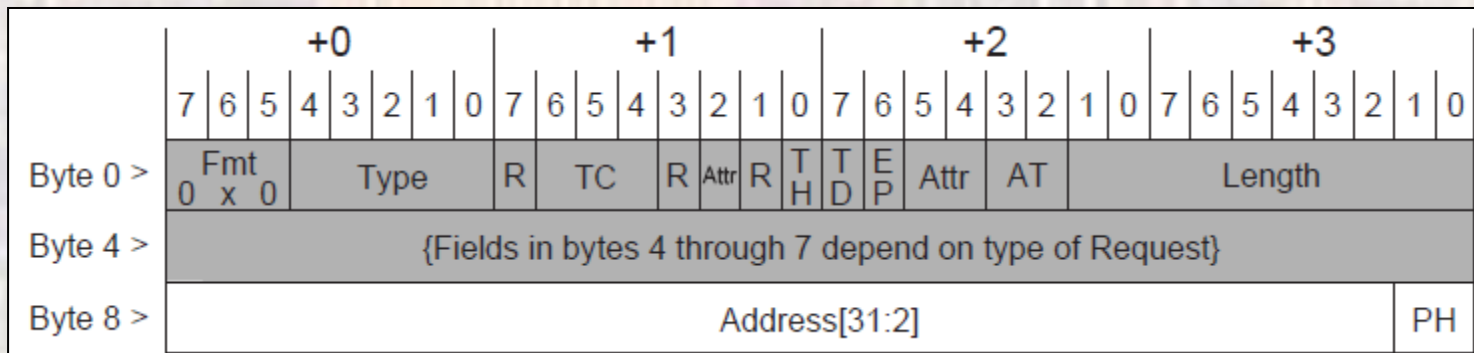

Parallel Communications - PCIe

- Transaction Layer Packets
- ID Based Routing

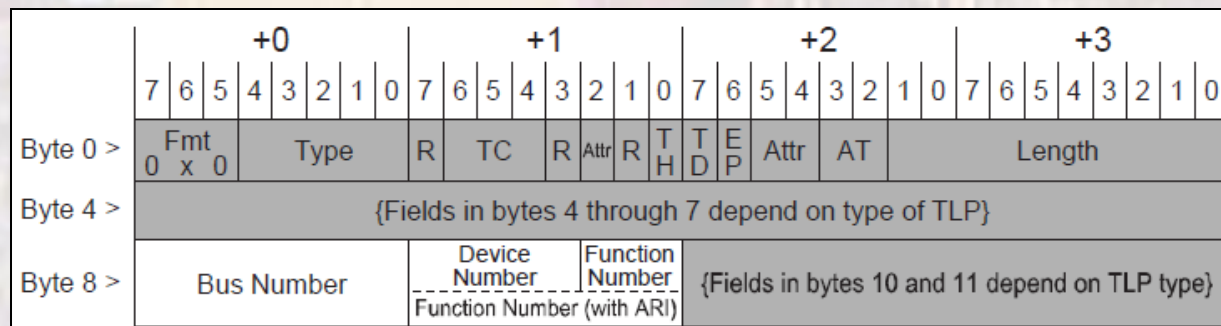
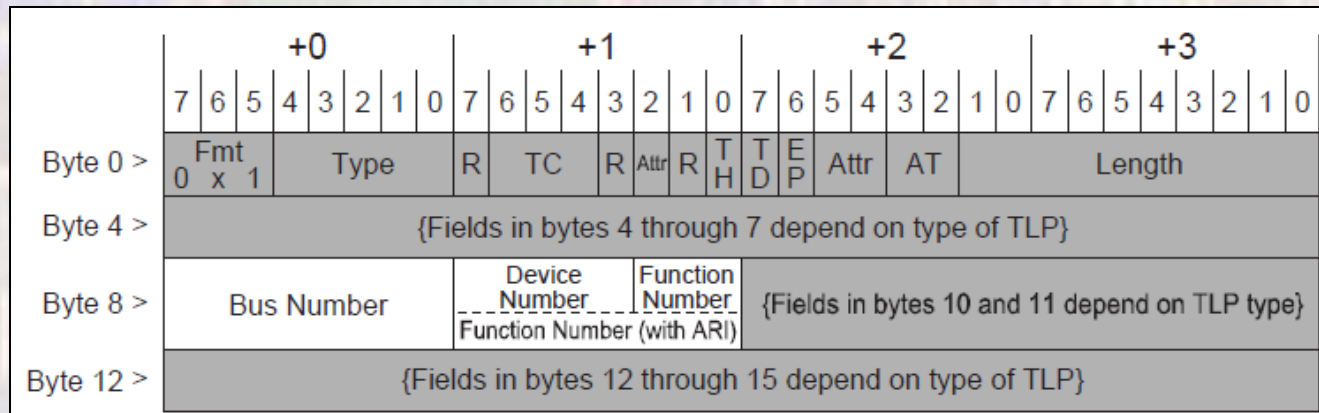

Parallel Communications - PCIe

- Transaction Layer Packets

- Data Word Byte Enable

- Provides Byte level enabling of the first and last data words
- All intermediate words (assuming >2 for length) must match both the first and last DW enable
- 32 bit words → 4 bytes
- 1st DWenable = 0110, last DWenable = 1100
 - Enable byte 1 and 2 of the 1st word, no intermediate words, bytes 2 and 3 of the last DW

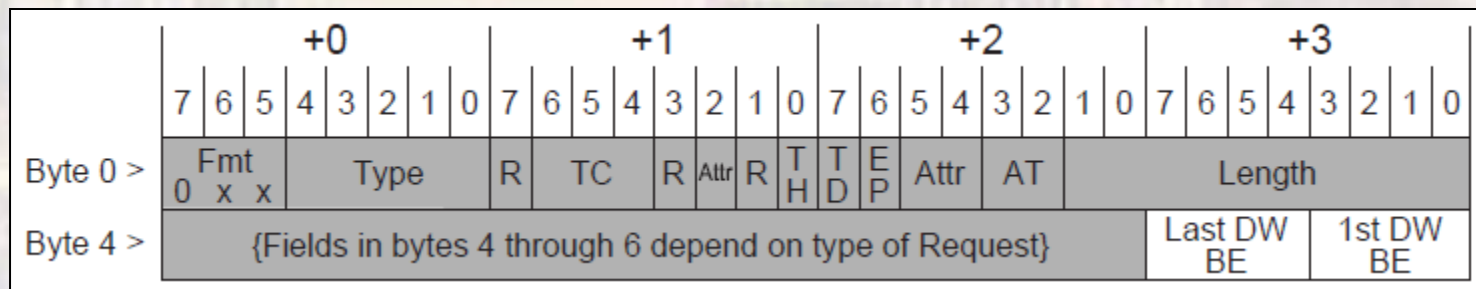

Parallel Communications - PCIe

- Transaction Layer Packets

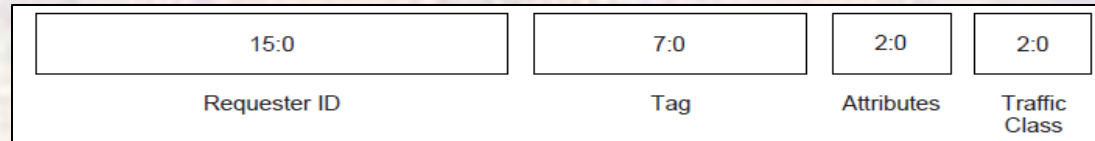

- Transaction ID

- Requester ID
- Tag
- Attributes – no-snoop?
- Transaction class – best effort, round robin, ...

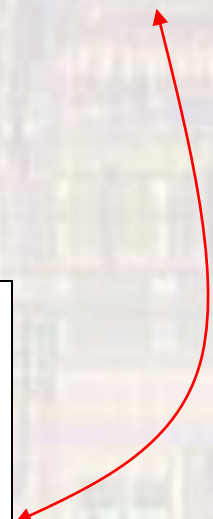
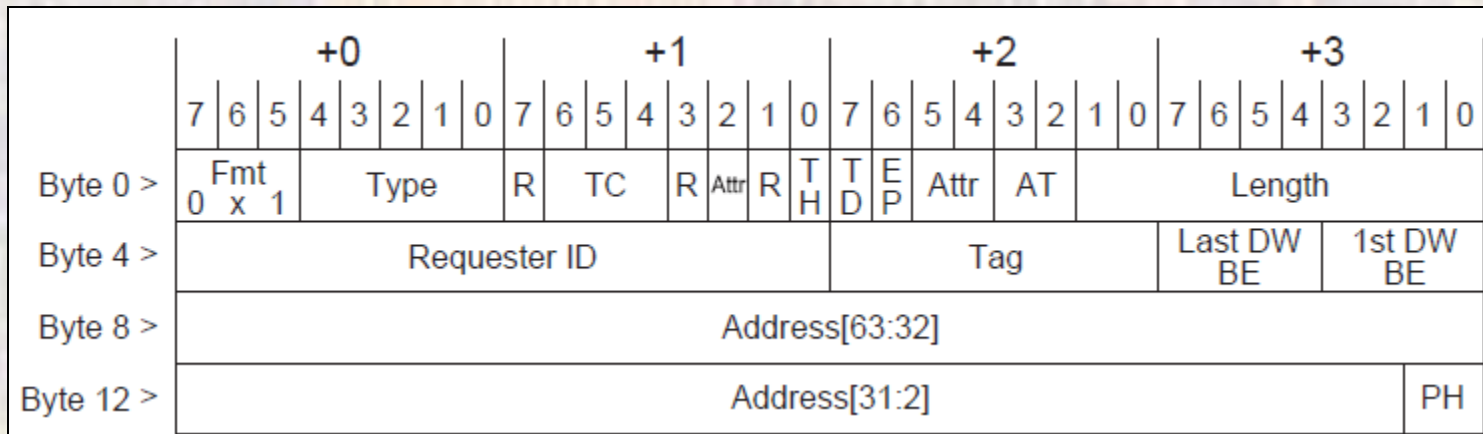

Parallel Communications - PCIe

- Transaction Layer Packets
- IO Transaction Request Example

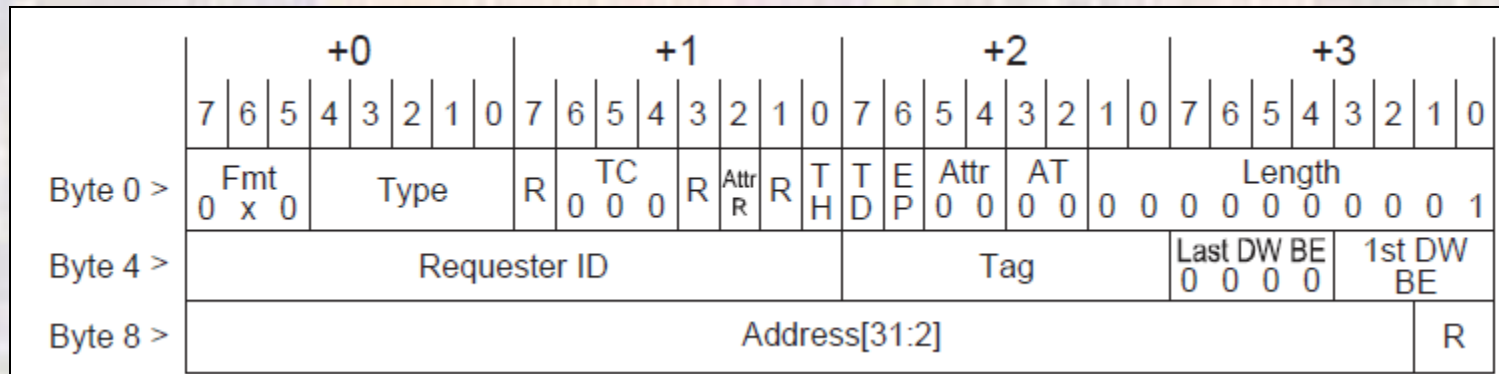

Parallel Communications - PCIe

- Transaction Layer Packets
- Configuration Transaction Request Example

	+0				+1				+2				+3																			
	7	6	5	4	3	2	1	0	7	6	5	4	3	2	1	0	7	6	5	4	3	2	1	0	7	6	5	4	3	2	1	0
Byte 0 >	Fmt 0 x 0		Type		R	TC 0 0 0		R	Attr R	R	T H	T D	E P	Attr 0 0	AT 0 0	Length 0 0 0 0 0 0 0 0 0 0 0 0 0 0 0 1																
Byte 4 >	Requester ID								Tag				Last DW BE 0 0 0 0		1st DW BE																	
Byte 8 >	Bus Number				Device Number		Function Number		Reserved		Ext. Reg. Number		Register Number		R																	

Parallel Communications - PCIe

- Transaction Layer Packets
 - Completion header
 - Header for any completion packets
 - E.g. results of a read

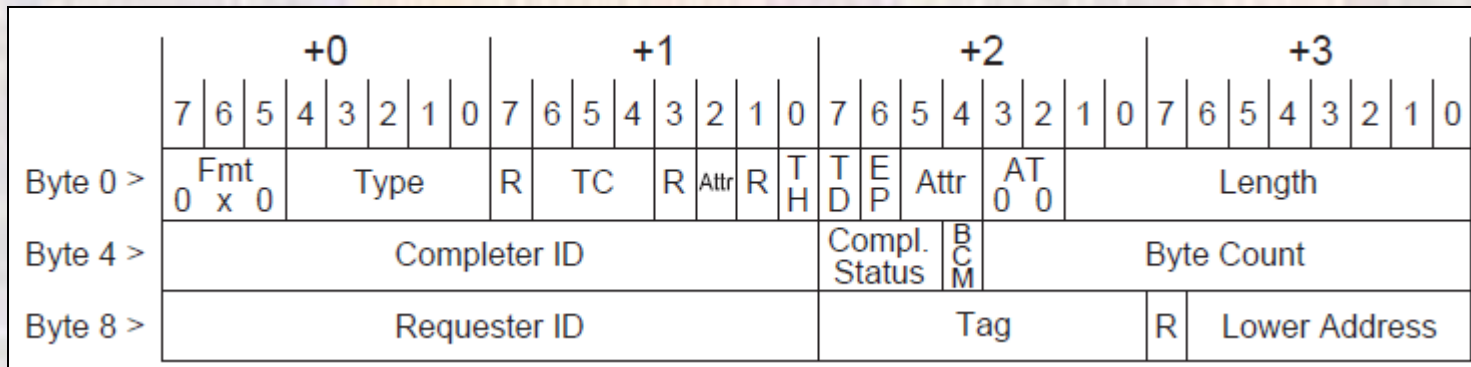

Completion Status[2:0] Field Value (b)	Completion Status
000	Successful Completion (SC)
001	Unsupported Request (UR)
010	Configuration Request Retry Status (CRS)
100	Completer Abort (CA)
all others	Reserved

Parallel Communications - PCIe

- Transaction Layer Packets
 - Optional Digest Field
 - Can be used for additional data checking at the Transaction Layer
 - Use a CRC – Cyclical Redundancy Check on the bits of the Transaction Layer Packet

Parallel Communications - PCIe

- Data Link Layer Packets - TLP
 - Prepends a sequence #
 - Used to detect entirely missing transmissions

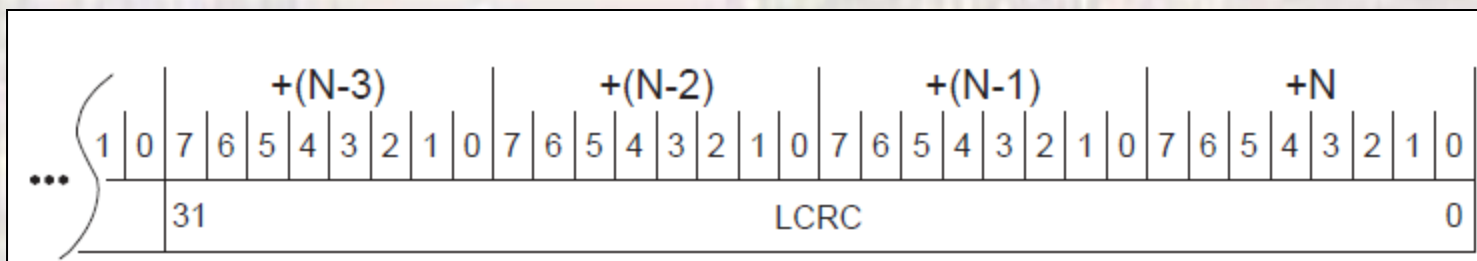
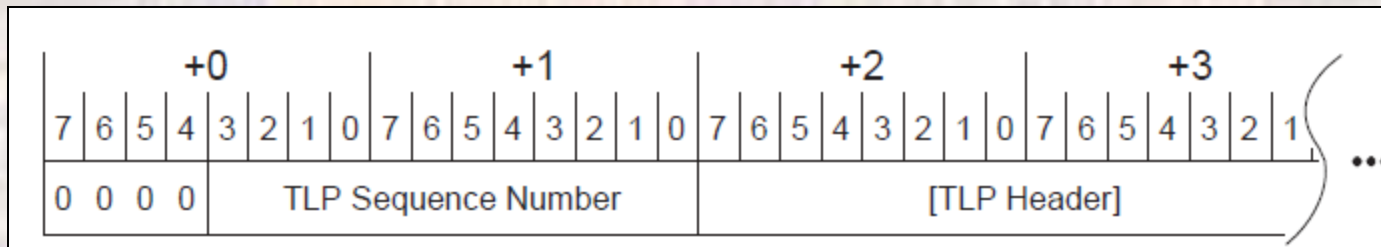

Parallel Communications - PCIe

- Data Link Layer Packets - DLLP
- General format

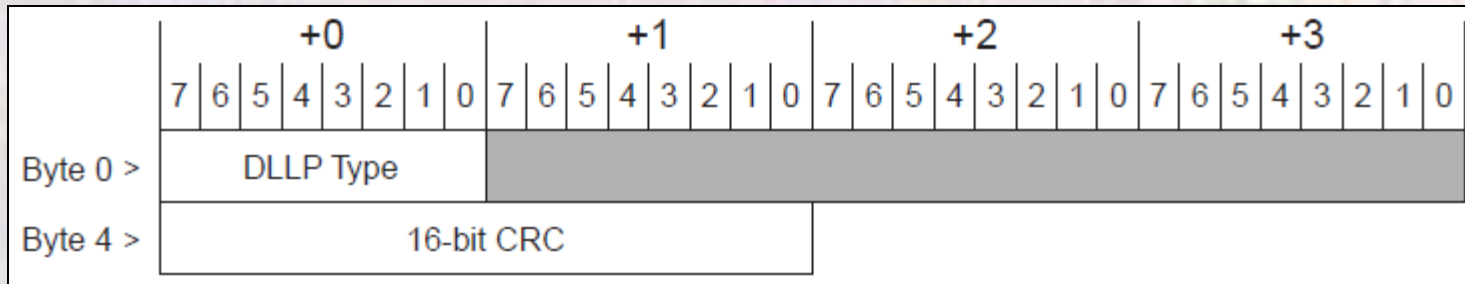

Parallel Communications - PCIe

- Data Link Layer Packets - DLLP

- General format

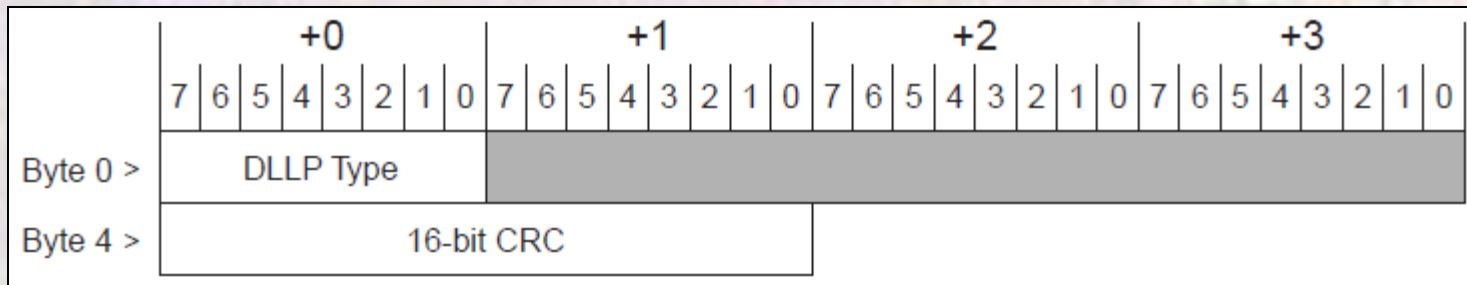

- Ack/Nak format

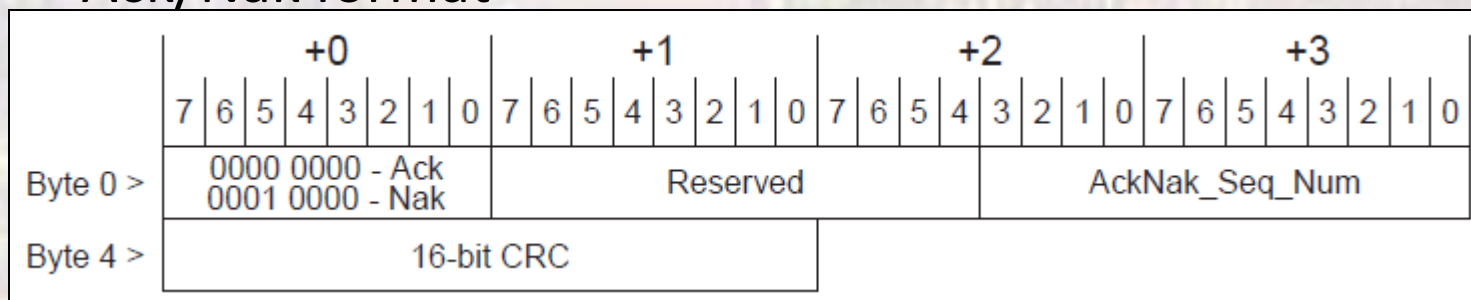

Parallel Communications - PCIe

- Physical Layer – Logical
- Framing

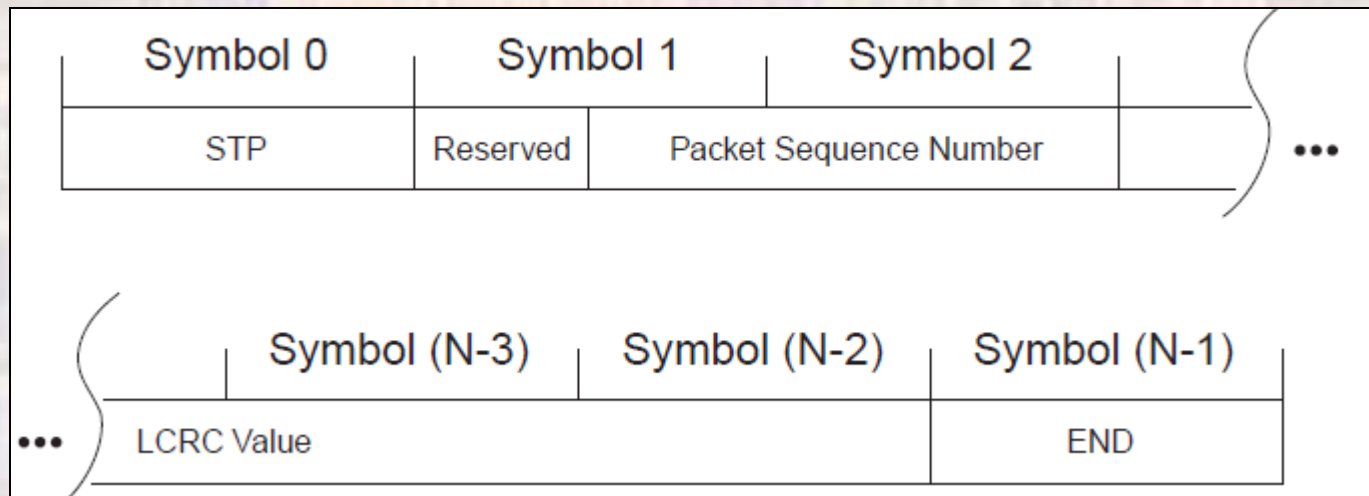

Parallel Communications - PCIe

- Physical Layer – Logical
- Framing Token – Start of TLP

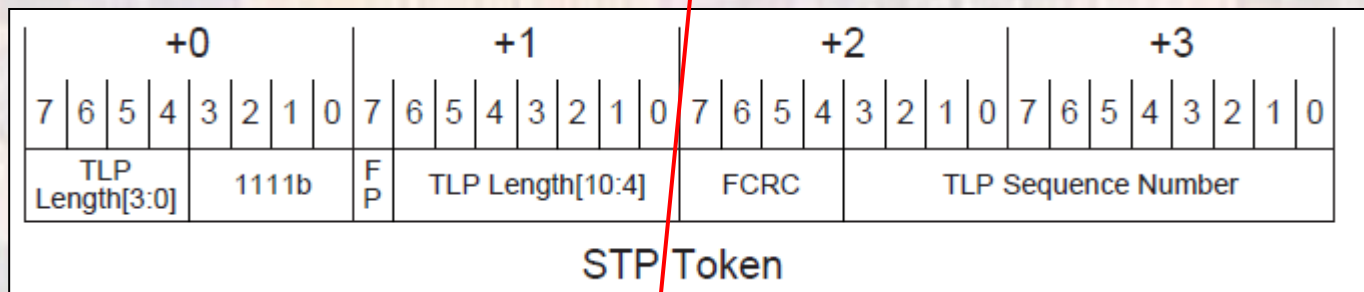

Parallel Communications - PCIe

- Physical Layer – Logical

- Striping

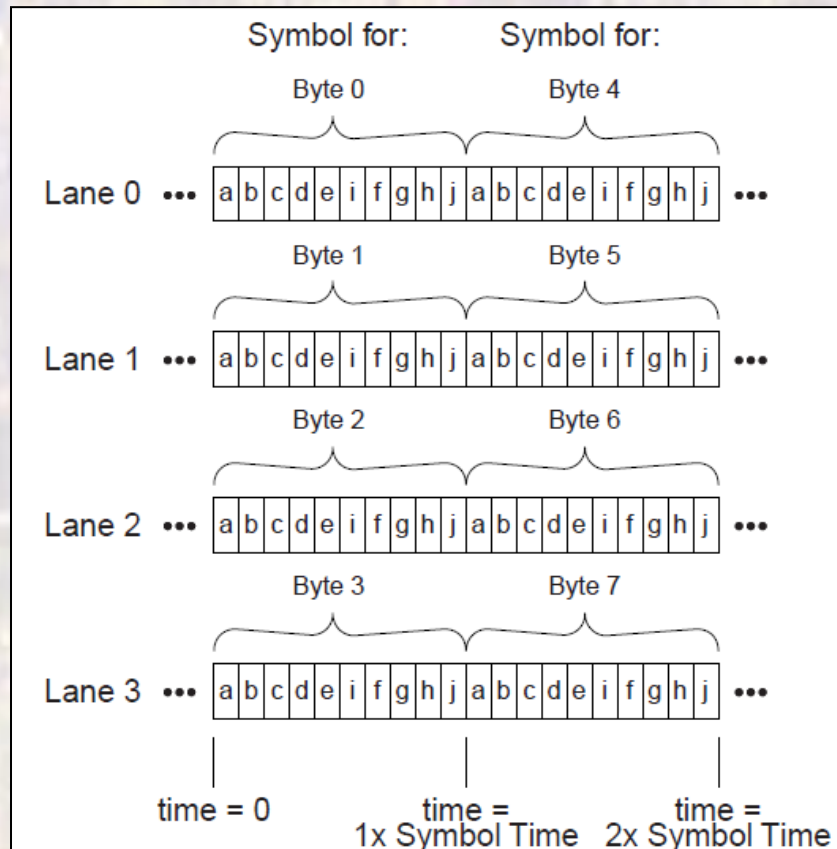

Parallel Communications - PCIe

- Packet example

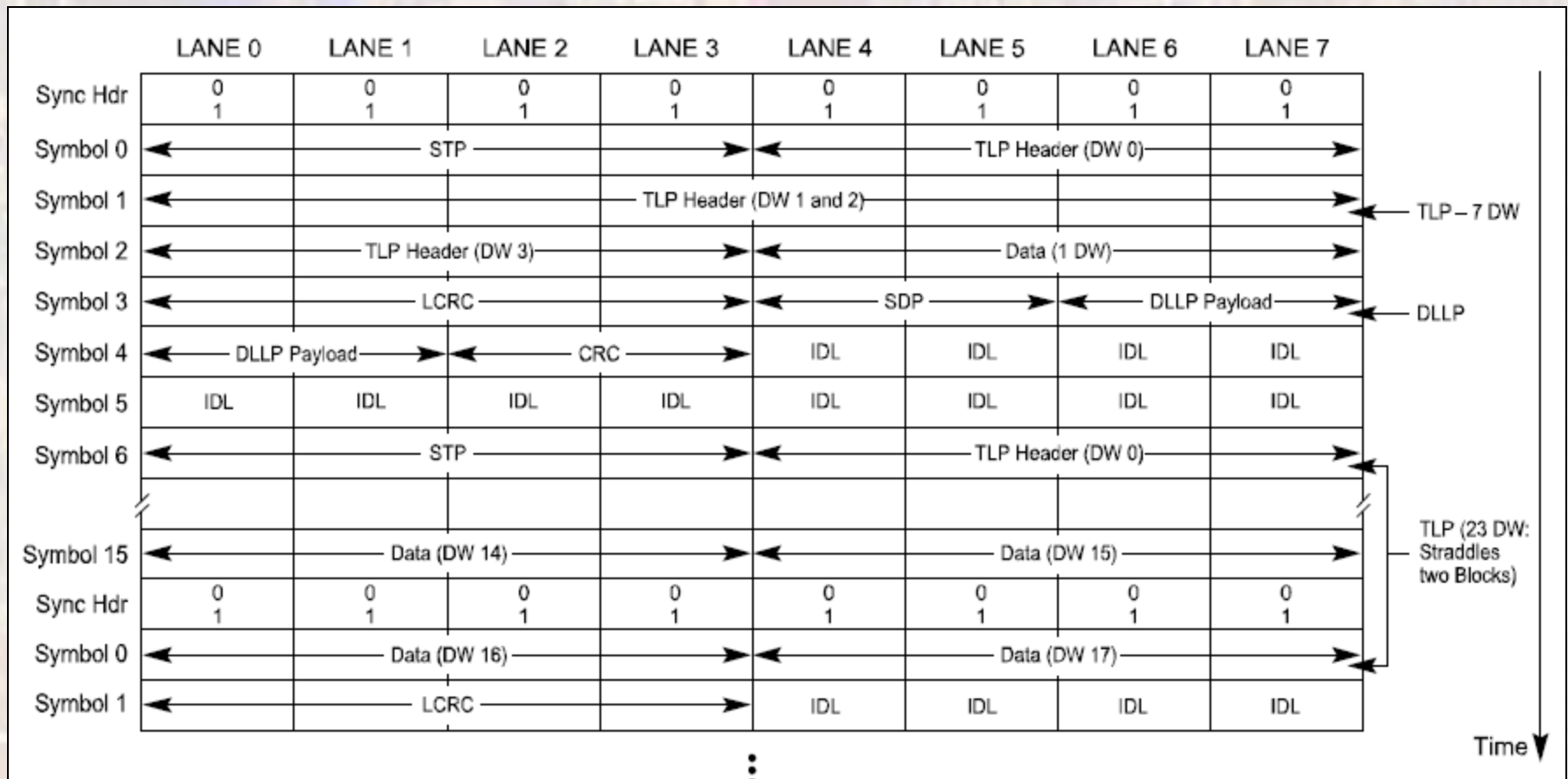

Parallel Communications - PCIe

- Physical Layer - Logical
 - Encoding
 - PCIe 1.x and 2.x use 8b/10b encoding
 - PCIe 3.x and 4.x use 128b/130b encoding
 - 8b/10b Encoding
 - Maps 8 bit symbols to 10 bit symbols
 - Coding ensures # of 1s and # of 0s differ by ≤ 2 for any string of 20 bits
 - Coding ensures no more than 5, 0s or 1s in a row
 - Provides enough transitions to do clock recovery
 - Provides for DC balance

Parallel Communications - PCIe

- Physical Layer - Logical

- 8b/10b Encoding
 - Bottom 5 bits → 6 bit code

5b/6b code				5b/6b code			
Input		RD = -1	RD = +1	Input		RD = -1	RD = +1
	EDCBA	abcdei			EDCBA	abcdei	
D.00	00000	100111	011000	D.16	10000	011011	100100
D.01	00001	011101	100010	D.17	10001	100011	
D.02	00010	101101	010010	D.18	10010	010011	
D.03	00011	110001		D.19	10011	110010	
D.04	00100	110101	001010	D.20	10100	001011	
D.05	00101	101001		D.21	10101	101010	
D.06	00110	011001		D.22	10110	011010	
D.07	00111	111000	000111	D.23 †	10111	111010	000101
D.08	01000	111001	000110	D.24	11000	110011	001100
D.09	01001	100101		D.25	11001	100110	
D.10	01010	010101		D.26	11010	010110	
D.11	01011	110100		D.27 †	11011	110110	001001
D.12	01100	001101		D.28	11100	001110	
D.13	01101	101100		D.29 †	11101	101110	010001
D.14	01110	011100		D.30 †	11110	011110	100001
D.15	01111	010111	101000	D.31	11111	101011	010100
				K.28	11100	001111	110000

Parallel Communications - PCIe

- Physical Layer - Logical

- 8b/10b Encoding

- Top 3 bits → 4 bit code

3b/4b code								
Input		RD = -1	RD = +1		Input		RD = -1	RD = +1
	HGF	fghj				HGF	fghj	
D.x.0	000	1011	0100		K.x.0	000	1011	0100
D.x.1	001	1001			K.x.1 †	001	0110	1001
D.x.2	010	0101			K.x.2 †	010	1010	0101
D.x.3	011	1100	0011		K.x.3 †	011	1100	0011
D.x.4	100	1101	0010		K.x.4	100	1101	0010
D.x.5	101	1010			K.x.5 †	101	0101	1010
D.x.6	110	0110			K.x.6 †	110	1001	0110
D.x.P7 †	111	1110	0001					
D.x.A7 †	111	0111	1000		K.x.7 †	111	0111	1000

Parallel Communications - PCIe

- Physical Layer – Logical
 - Symbol Encoding

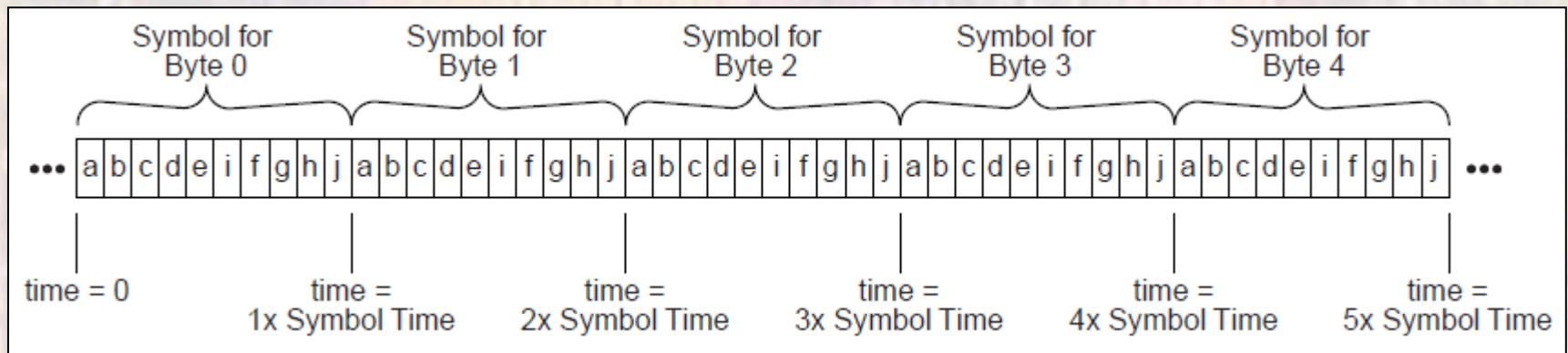

Parallel Communications - PCIe

- Physical Layer

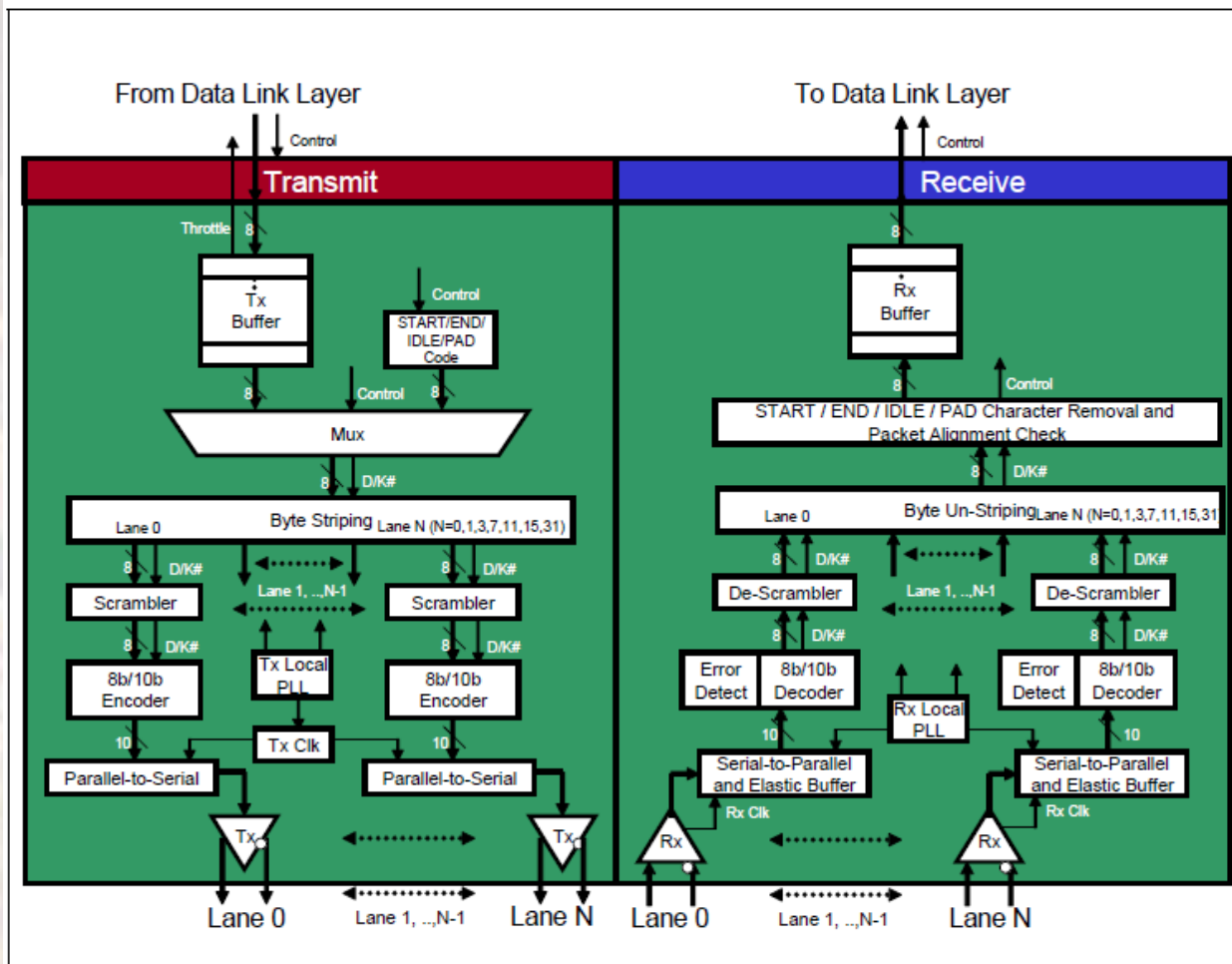

Parallel Communications - PCIe

- PCIe signaling
 - 2 wires for each transmission
 - Differential signals
 - Differential receivers and transmitters
 - AC coupled \rightarrow different levels at each end
 - How do we do this ?
 - Differential Pk-Pk voltages from 800mv to 1.2v
 - $+V_{pp} \rightarrow 1$ $-V_{pp} \rightarrow 0$
 - Common mode range from 0 to 3.6v

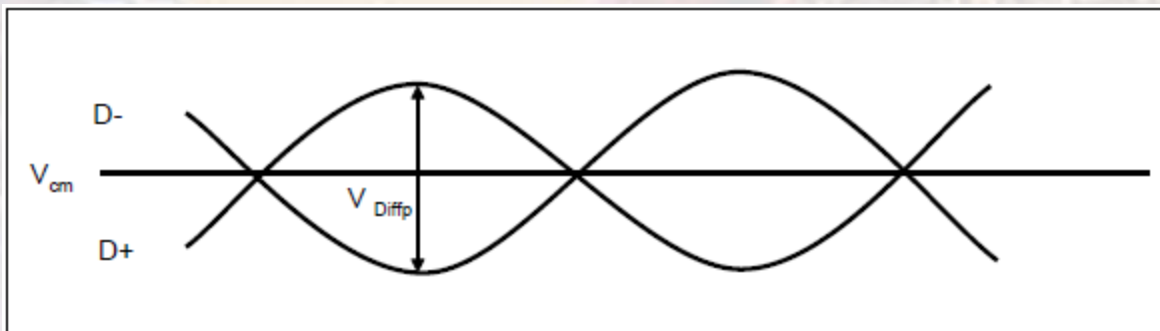

Parallel Communications - PCIe

- PCIe signaling
 - LVDS – Low Voltage Differential Signalling

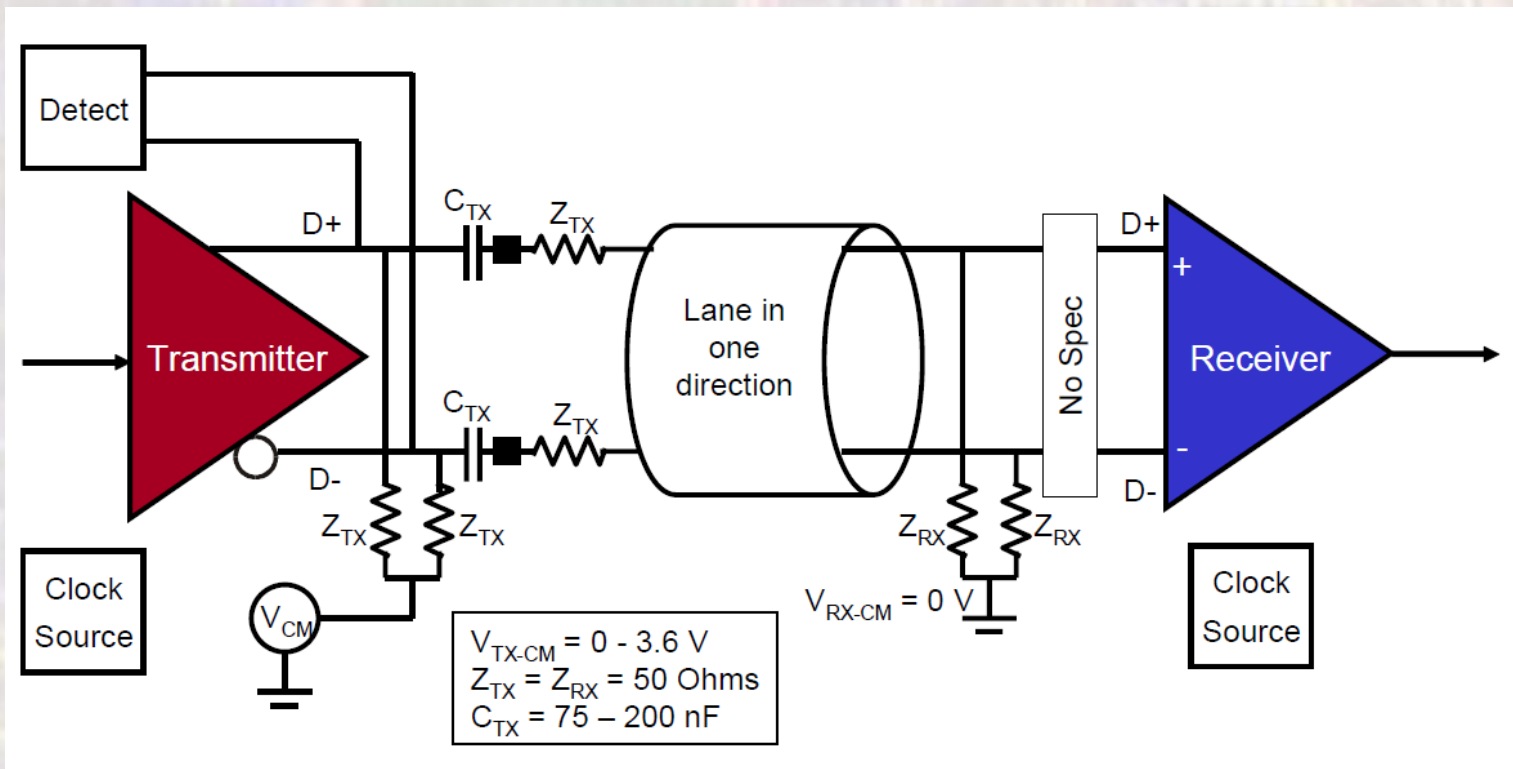

Parallel Communications - PCIe

- Electrical

